

DRAPER[®]

INSTRUCTIONS FOR 135W 230V Multi-Tool Kit with Flexible Drive Shaft

Stock No.53111

Part No.PT142K

IMPORTANT: PLEASE READ THESE INSTRUCTIONS CAREFULLY TO ENSURE THE SAFE AND EFFECTIVE USE OF THIS PRODUCT.



DRAPER[®]

GENERAL INFORMATION

These instructions accompanying the product are the original instructions. This document is part of the product, keep it for the life of the product passing it on to any subsequent holder of the product. Read all these instructions before assembling, operating or maintaining this product.

This manual has been compiled by Draper Tools describing the purpose for which the product has been designed, and contains all the necessary information to ensure its correct and safe use. By following all the general safety instructions contained in this manual, it will ensure both product and operator safety, together with longer life of the product itself. All photographs and drawings in this manual are supplied by Draper Tools to help illustrate the operation of the product. Whilst every effort has been made to ensure the accuracy of information contained in this manual, the Draper Tools policy of continuous improvement determines the right to make modifications without prior warning.

1. TITLE PAGE

1.1 INTRODUCTION:

USER MANUAL FOR:

135W 230V MULTI-TOOL KIT WITH FLEXIBLE DRIVE SHAFT

Stock no. 53111

Part no. PT142K

1.2 REVISIONS:

Date first published May 2014

As our user manuals are continually updated, users should make sure that they use the very latest version.

Downloads are available from: <http://www.drapertools.com/b2c/b2cmanuals.pgm>

DRAPER TOOLS LIMITED

HURSLEY ROAD

CHANDLER'S FORD

EASTLEIGH

HAMPSHIRE

SO53 1YFUK

WEBSITE: www.drapertools.com

PRODUCT HELPLINE: +44 (0) 23 8049 4344

GENERAL FAX: +44 (0) 23 8026 0784

1.3 UNDERSTANDING THIS MANUALS SAFETY CONTENT:

WARNING! Information that draws attention to the risk of injury or death.

CAUTION! Information that draws attention to the risk of damage to the product or surroundings.

1.4 COPYRIGHT © NOTICE:

Copyright © Draper Tools Limited.

Permission is granted to reproduce this publication for personal & educational use only. Commercial copying, redistribution, hiring or lending is prohibited.

No part of this publication may be stored in a retrieval system or transmitted in any other form or means without written permission from Draper Tools Limited.

In all cases this copyright notice must remain intact.

2. CONTENTS

2.1 CONTENTS

	<i>Page content</i>	<i>Page</i>
1	TITLE PAGE	
	1.1 INTRODUCTION	2
	1.2 REVISION HISTORY.....	2
	1.3 UNDERSTANDING THIS MANUAL	2
	1.4 COPYRIGHT NOTICE.....	2
2	CONTENTS	
	2.1 CONTENTS	3
3	GUARANTEE	
	3.1 GUARANTEE	4
4	INTRODUCTION	
	4.1 SCOPE	5
	4.2 SPECIFICATION	5
	4.3 HANDLING & STORAGE	5
5	HEALTH & SAFETY INFORMATION	
	5.1 GENERAL SAFETY INSTRUCTIONS FOR POWER TOOL USE	6
	5.2 ADDITIONAL SAFETY INSTRUCTIONS.....	7A
	5.3 CONNECTION TO THE POWER SUPPLY	7A
6	TECHNICAL DESCRIPTION	
	6.1 IDENTIFICATION	8B
7	UNPACKING & CHECKING	
	7.1 PACKAGING.....	8A
	7.2 WHAT'S IN THE BOX	8A
8	BASIC MULTI-TOOL OPERATIONS	
	8.1 ACCESSORY INSTALLATION/REPLACEMENT	9
	8.2 FITTING FLEXIBLE DRIVE SHAFT	9
	8.3 ON AND OFF SWITCH.....	9
9	BASIC MULTI-TOOL OPERATIONS	
	9.1 APPLICATIONS	10
	9.2 HOLDING THE TOOLS.....	10
	9.3 FITTING A CUTTING/SANDING DISC	10
	9.4 FITTING THE SANDING DRUMS	10
10	MAINTENANCE	
	10.1	11
11	OPTIONAL ACCESSORIES.....	12
12	EXPLANATION OF SYMBOLS	
	12.1 EXPLANATION OF SYMBOLS	13
13	DISPOSAL	
	13.1 DISPOSAL	14
	DECLARATION OF CONFORMITY	ENCLOSED

3. GUARANTEE

3.1 GUARANTEE

Draper tools have been carefully tested and inspected before shipment and are guaranteed to be free from defective materials and workmanship.

Should the tool develop a fault, please return the complete tool to your nearest distributor or contact Draper Tools Limited, Chandler's Ford, Eastleigh, Hampshire, SO53 1YF. England. Telephone: (023) 8026 6355.

A proof of purchase must be provided with the tool.

If upon inspection it is found that the fault occurring is due to defective materials or workmanship, repairs will be carried out free of charge. This guarantee period covering parts/labour is 12 months from the date of purchase. The guarantee is extended to 24 months for parts only. This guarantee does not apply to normal wear and tear, nor does it cover any damage caused by misuse, careless or unsafe handling, alterations, accidents, or repairs attempted or made by any personnel other than the authorised Draper warranty repair agent.

Note: If the tool is found not to be within the Terms of Warranty, repair and carriage charges will be quoted and made accordingly.

This guarantee applies in lieu of any other guarantee expressed or implied and variations of its terms are not authorised.

Your Draper guarantee is not effective unless you can produce upon request a dated receipt or invoice to verify your proof of purchase within the guarantee period.

Please note that this guarantee is an additional benefit and does not affect your statutory rights.

Draper Tools Limited.

Note: This tool is intended for domestic use only.

4. INTRODUCTION

4.1 SCOPE

Ideal for hobby work-tasks such as drilling, milling, grinding, engraving, cutting, polishing, sharpening, buffing and removing rust.

4.2 SPECIFICATION

Stock No.....	53111
Part No.....	PT142K
Rated voltage.....	230V~50Hz
Rated input.....	135W
Speed (no load).....	10,000-35,000min ⁻¹
Collet capacity.....	3(2.0, 2.4, and 3.0mm)
Sound pressure level.....	77dB(A)
Sound power level.....	88dB(A)
Vibration level.....	2.3m/s ²
Weight (Excluding Accessories).....	700g

4.3 HANDLING & STORAGE

Take care when handling and lifting. Do not drop this machine.

Store in a dry location out of the reach of children.

5. HEALTH & SAFETY INFORMATION

5.1 GENERAL POWER TOOL SAFETY WARNINGS

WARNING: Read all safety warnings and all instructions. Failure to follow the warnings and instructions may result in electric shock, fire and/or serious injury.

Save all warnings and instructions for future reference.

The term "power tool" in the warnings refers to your mains operated (corded) power tool or battery-operated (cordless) power tool.

1) Work area safety

- a) **Keep work area clean and well lit.** Cluttered or dark areas invite accidents.
- b) **Do not operate power tools in explosive atmospheres, such as in the presence of flammable liquids, gases or dust.** Power tools create sparks which may ignite the dust or fumes.
- c) **Keep children and bystanders away while operating a power tool.** Distractions can cause you to lose control.

2) Electrical safety

- a) **Power tool plugs must match the outlet. Never modify the plug in any way. Do not use any adapter plugs with earthed (grounded) power tools.** Unmodified plugs and matching outlets will reduce risk of electric shock.
- b) **Avoid body contact with earthed or grounded surfaces such as pipes, radiators, ranges and refrigerators.** There is an increased risk of electric shock if your body is earthed or grounded.
- c) **Do not expose power tools to rain or wet conditions.** Water entering a power tool will increase the risk of electric shock.
- d) **Do not abuse the cord. Never use the cord for carrying, pulling or unplugging the power tool. Keep cord away from heat, oil, sharp edges or moving parts.** Damaged or entangled cords increase the risk of electric shock.
- e) **When operating a power tool outdoors, use an extension cord suitable for outdoor use.** Use of a cord suitable for outdoor use reduces the risk of electric shock.
- f) **If operating a power tool in a damp location is unavoidable, use a residual current device (RCD) protected supply.** Use of an RCD reduces the risk of electric shock.

3) Personal safety

- a) **Stay alert, watch what you are doing and use common sense when operating a power tool. Do not use a power tool while you are tired or under the influence of drugs, alcohol or medication.** A moment of inattention while operating power tools may result in serious personal injury.
- b) **Use personal protective equipment. Always wear eye protection.** Protective equipment such as dust mask, non-skid safety shoes, hard hat, or hearing protection used for appropriate conditions will reduce personal injuries.
- c) **Prevent unintentional starting. Ensure the switch is in the off position before connecting to power source and/or battery pack, picking up or carrying the tool.** Carrying power tools with your finger on the switch or energising power tools that have the switch on invites accidents.
- d) **Remove any adjusting key or wrench before turning the power tool on.** A wrench or a key left attached to a rotating part of the power tool may result in personal injury.

- e) **Do not overreach. Keep proper footing and balance at all times.** This enables better control of the power tool in unexpected situations.
- f) **Dress properly. Do not wear loose clothing or jewellery. Keep your hair, clothing and gloves away from moving parts.** Loose clothes, jewellery or long hair can be caught in moving parts.
- g) **If devices are provided for the connection of dust extraction and collection facilities, ensure these are connected and properly used.** Use of these devices can reduce dust-related hazards.

4) Power tool use and care

- a) **Do not force the power tool. Use the correct power tool for your application.** The correct power tool will do the job better and safer at the rate for which it was designed.
- b) **Do not use the power tool if the switch does not turn it on and off.** Any power tool that cannot be controlled with the switch is dangerous and must be repaired.
- c) **Disconnect the plug from the power source and/or battery pack from the power tool before making any adjustments, changing accessories, or storing power tools.** Such preventive safety measures reduce the risk of starting the power tool accidentally.
- d) **Store idle power tools out of the reach of children and do not allow persons unfamiliar with the power tool or these instructions to operate the power tool.** Power tools are dangerous in the hands of untrained users.
- e) **Maintain power tools. Check for misalignment or binding of moving parts, breakage of parts and any other condition that may affect the power tool's operation. If damaged, have the power tool repaired before use.** Many accidents are caused by poorly maintained power tools.
- f) **Keep cutting tools sharp and clean.** Properly maintained cutting tools with sharp cutting edges are less likely to bind and are easier to control.
- g) **Use the power tool, accessories and tool bits etc. in accordance with these instructions, taking into account the working conditions and the work to be performed.** Use of the power tool for operations different from those intended could result in a hazardous situation.

5) Service

- a) **Have your power tool serviced by a qualified repair person using only identical replacement parts.** This will ensure that the safety of the power tool is maintained.

5. HEALTH & SAFETY INFORMATION

5.2 ADDITIONAL SAFETY INSTRUCTIONS

- Wear ear protectors with impact drills. Exposure to noise can cause hearing loss.
- Use auxiliary handles supplied with the tool. Loss of control can cause personal injury.
- Wear eye protection.
- Wear dust mask.

5.3 CONNECTION TO THE POWER SUPPLY

Make sure the power supply information on the machine's rating plate are compatible with the power supply you intend to connect it to.

This drill comes supplied with a UK standard 3 pin plug fitted. It is designed for connection to a domestic power supply rated at 230V AC.

It is a Class 2 machine (double insulated); is designed for connection to a power supply matching that detailed on the rating label and compatible with the plug fitted.

If an extension lead is required, use an approved and compatible lead rated for this appliance. Follow all the instruction supplied with the extension lead.

This product requires no earth connection as supplementary insulation is applied to the basic insulation to protect against electric shock in the event of failure of the basic insulation.

Apart from replacing the fuse in the plug, no other electrical work is recommended on this drill.

- *Blank page* -

7. UNPACKING & CHECKING

7.1 PACKAGING

Carefully remove the multi-tool from the packaging and examine it for any sign of damage that may have happened during shipping. Lay the contents out and check them against the parts shown below. If any part is damaged or missing; please contact the Draper Helpline (the telephone number appears on the Title page) and do not attempt to use the product. The packaging material should be retained at least during the guarantee period: in case the machine needs to be returned for repair.

Warning! Some of the packaging materials used may be harmful to children. Do not leave any of these materials in the reach of children.

If any of the packaging is to be thrown away, make sure they are disposed of correctly; according to local regulations.

7.2 WHAT'S IN THE BOX?

As well as the multi-tool; there are several parts not fitted or attached to it.

- ⑧ Flexible shaft
- ⑨ Collets x3
- ⑩ Collet spanner/ plain slot screwdriver
- ⑪ Bristle brush
- ⑫ Holder for cutting/sanding/grinding discs
- ⑬ Holder for felt polishing wheels.
- ⑭ Diamond grinding point x3
- ⑮ Holder for large sanding drum
- ⑯ Holder for small sanding drum
- ⑰ HSS drill bits (2.0, 2.4 & 3.0mm) x3

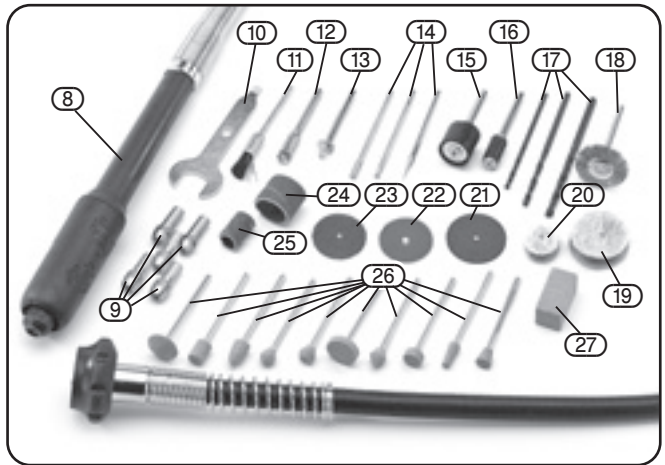

- ⑱ Brass wheel
- ⑲ Large felt polishing wheel x5
- ⑳ Small felt polishing wheel x5
- ㉑ Cut off wheel (Ø 22mm x 1mm) x25
- ㉒ Fine polishing disc (600 Grit-green) x12
- ㉓ Sanding disc (180 Grit-red) x10
- ㉔ Large sanding drum (120 Grit) x8
- ㉕ Small sanding drum (120 Grit) x8
- ㉖ Aluminium oxide grinding point x10
- ㉗ Sharpening stone

NOTE: To ensure safe use do not use the polishing wheels faster than 25,000rpm: When you purchase additional accessories check the safe working speed is compatible with the tool.

6. TECHNICAL DESCRIPTION

6.1 IDENTIFICATION



- ① Hook
- ② On/Off Switch
- ③ Spindle Lock
- ④ Collar

- ⑤ Collet nut
- ⑥ Variable Speed Dial
- ⑦ Moulded Plug and Cable

8. BASIC MULTI-TOOL OPERATIONS

8.1 ACCESSORY INSTALLATION/ REPLACEMENT - FIG. 1

This Multi-Tool is designed for use with 1.9, 2.3 & 3.0mm shank accessories only.

WARNING: Use bits of the correct shank diameter suitable for the speed of the tool.

Selection of the correct accessory, suitable for the intended application is vital. Seek guidance if uncertain of selection.

Press the spindle lock button (3) and unscrew the collet nut (5) using the spanner supplied.

Choose from the collets provided, the appropriate size for the accessory shank. If the size is not known insert the bit into the collet. The collet which offers a machine fit to the shank is the correct one to use. Do not force the bit into the collet.

Place the collet into the spindle before loosely replacing the collet nut (5).

Slide the accessory in as far as possible before tightening the collet nut. Press the spindle lock button (3) and tighten the collet nut with the spanner provided to lock the bit in place. If the accessory seems loose, reduce the collet size to ensure the bit is secured correctly.

NOTE: Do not overtighten the collet nut

To lock the spindle inside the flexible shaft (8), pull back on the collar (8.1).

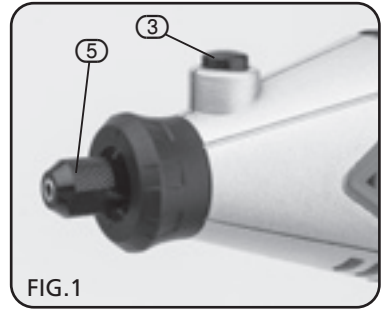
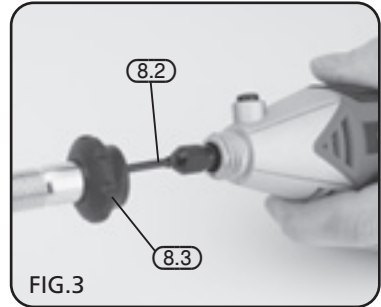
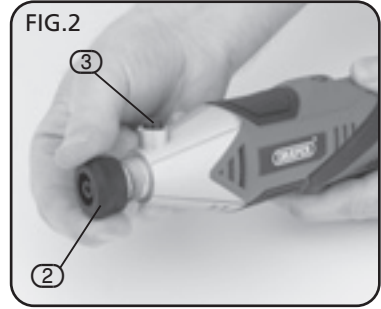

FIG.2



8.2 FITTING FLEXIBLE DRIVE SHAFT - FIGS. 2 - 3

Remove collar (2). Depressing spindle lock button (3) and loosen the collet nut. Install the 3.0mm collet and loosely replace the collet nut.

Insert the flexible drive shaft rod (8.2) into the collet chuck and lock. Screw the drive shaft collar (8.3) onto housing.

8.3 SWITCHING ON AND OFF - FIG. 4

Press switch (2) into the 'I' position. This will start the machine. Press switch to the 'O' position - this will stop the machine.

Using the variable speed dial (6) will enable you to alter the speed of the collet chuck:

Position 1 - SLOW

Position 3 - MEDIUM

Position 6 - FAST

Select the correct speed for the work and type of bit you are using.

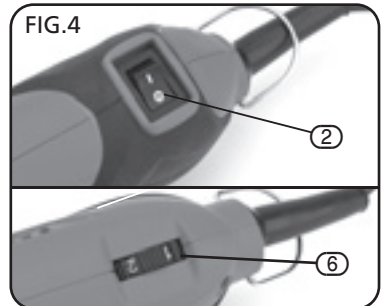

9. BASIC MULTI-TOOL OPERATIONS

8.4 APPLICATIONS:

Your multi-tool can be used for drilling, grinding, polishing, milling and brushing. Other jobs like engraving, cutting and removing rust are also possible. It can be used on most wood, metal, glass and ceramics. It is a good idea to practice on a scrap piece of material. Best results are achieved by an even speed and pressure (not too hard). Use lower speeds for larger tools and higher speeds for smaller tools.

WARNING: Excessive force on this machine will cause the motor to overheat and fail. This is not covered by the guarantee.

8.5 HOLDING THE TOOL - FIGS. 5 - 6

For jobs such as milling or engraving where precision is required, hold the multi-tool like a pen.

Care should be taken not to fully cover exhaust vents. Covering the vents will cause the machine to overheat and fail.

For heavier work like cutting or grinding hold the multi-tool in the palm of your hand.



FIG.5



FIG.6

8.5 FITTING A CUTTING/SANDING DISC - FIG. 7

With the disc holder (12) in the chuck, remove the screw using the plain slot screwdriver (incorporated in the spanner handle tip). Remove one of the spacing washers from the end. Insert the screw through the cutting disc, the washer and secure into the holder (Do not over tighten).

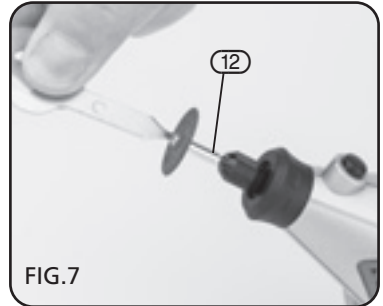

FIG.7

8.6 FITTING THE SANDING DRUMS - FIG. 8

To fit a drum (24), firstly loosen the small screw in the top of the holder (15). This will allow the rubber to relax. Slide the sanding drum onto the holder. To secure simply tighten the screw and the rubber drum will swell, gripping the drum. (Do not over tighten).

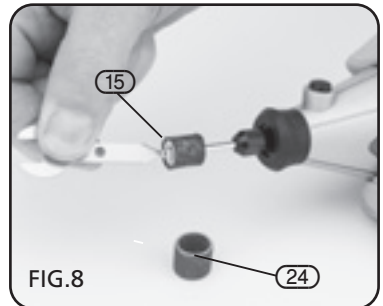

FIG.8

10. MAINTENANCE

10.1 MAINTENANCE

NOTE: Remove the plug from the socket before carrying out adjustment, servicing or maintenance.

The Multi-Tool does not require any special maintenance. Regularly clean/vacuum the ventilation slots. Use only a mild cleaner and a damp cloth to clean the tool.

11. OPTIONAL ACCESSORIES

Stock No.	Part No.	Description	Packed Qty
44479	APT41A	Wire Brush	1
44480	APT42A	Bristle Brush	1
44460	APT43A	Holder for Cutting/Sanding/Grinding Disc	1
44473	APT44A	Holder for Felt Wheels	1
44475	APT46A	Milling Point 	1
44476	APT47A	Milling Point 	1
44467	APT48A	Diamond Grinding Point 	1
44471	APT49A	Diamond Grinding Point 	1
44469	APT50A	Diamond Grinding Point 	1
44466	APT51A	Diamond Grinding Point 	1
44470	APT52A	Diamond Grinding Point 	1
63073	APT57	HSS Drill Bit 2.0mm	1
44465	APT59A	Grinding Point 80 Grit 	1
44461	APT60A	Grinding Point 80 Grit 	1
44462	APT61A	Grinding Point 80 Grit 	1
44463	APT62A	Grinding Point 80 Grit 	1
44464	APT63A	Grinding Point 80 Grit 	1
44456	APT66A	Cutting Disc 120 Grit 0.64mm	30
44472	APT67A	Felt Polishing Wheel 24mmØ	3
44475	APT68A	Cloth Polishing Wheel	1
44454	APT69A	Grinding Wheel 80 Grit	6
44477	APT71A	Brass Wheel	1
44478	APT72A	Bristle Wheel	1
86847	APT94	Sanding Drum 80 Grit (Large)	6
87366	APT102	Sanding Drum 150 Grit (Large)	6
86850	APT95	Holder for Sanding Drums (Large)	1
86851	APT96	1.6mm Collet	1
86852	APT97	2.0mm Collet	1
86853	APT98	2.4mm Collet	1
86854	APT99	3.0mm Collet	1
86855	APT100	3.2mm Collet	1
86856	APT101	Spanner/Plain Slot screwdriver	1

12. EXPLANATION OF SYMBOLS

11.1 EXPLANATION OF SYMBOLS



WEEE
Do not dispose of Waste Electrical
& Electronic Equipment in with
domestic rubbish



Class II construction
(Double insulated)



Warning!
Wear suitable respiratory protection.



Warning!
Wear suitable respiratory protection.



Warning!
Wear ear defenders (During grinding
operations).



Warning!
Read the instruction manual

13. DISPOSAL

13.1 DISPOSAL

- At the end of the machine's working life, or when it can no longer be repaired, ensure that it is disposed of according to national regulations.
- Contact your local authority for details of collection schemes in your area.

In all circumstances:

- Do not dispose of power tools with domestic waste.
- Do not incinerate.
- Do not abandon in the environment.
- Do not dispose of WEEE* as unsorted municipal waste.



* Waste Electrical & Electronic Equipment.

- **DRAPER TOOLS LIMITED,**
Hursley Road, Chandler's Ford,
Eastleigh, Hampshire. SO53 1YF. U.K.
- **Helpline:** (023) 8049 4344
- **Sales Desk:** (023) 8049 4333
- **Internet:** www.drapertools.com
- **E-mail:** sales@drapertools.com
- **Sales Fax:** (023) 8049 4209
- **General Enquiries:** (023) 8026 6355
- **Service/Warranty Repair Agent**
For aftersales servicing or warranty repairs, please
contact the Draper Tools Helpline for details of an
agent in your local area.

YOUR DRAPER STOCKIST