

Thank you for purchasing a Sealey product. Manufactured to a high standard this product will, if used according to these instructions and properly maintained, give you years of trouble free performance.

IMPORTANT: PLEASE READ THESE INSTRUCTIONS CAREFULLY. NOTE THE SAFE OPERATIONAL REQUIREMENTS, WARNINGS & CAUTIONS. USE THE PRODUCT CORRECTLY AND WITH CARE FOR THE PURPOSE FOR WHICH IT IS INTENDED. FAILURE TO DO SO MAY CAUSE DAMAGE OR PERSONAL INJURY, AND WILL INVALIDATE THE WARRANTY. PLEASE KEEP INSTRUCTIONS SAFE FOR FUTURE USE.

The use of symbols in this document is to attract your attention to possible danger. The symbols and warnings themselves do not eliminate any danger, nor are they substitutes for proper accident prevention measures.

1. SAFETY INSTRUCTIONS

1.1 GENERAL SAFETY

- ❑ **WARNING!** Ensure Health & Safety, local authority, and general workshop practice regulations are adhered to when using this bench.
- ✓ Locate bench in a suitable working area.
- ✓ Keep the work area clean, uncluttered and ensure there is adequate lighting.
- ❑ **WARNING!** Use bench on level and solid ground, preferably concrete. *Avoid tarmac/adam since the bench may sink into the surface.*
- ✓ Keep the bench clean and tidy in accordance with good workshop practice.
- ✓ Keep children and unauthorised persons away from the working area.
- x **DO NOT** use the bench for any purpose other than that for which it is designed.
- x **DO NOT** undertake work on the bench without the workpiece being adequately secured. Use clamps or a vice (not included) to secure the workpiece. Available from your Sealey dealer.
- x **DO NOT** use the bench out of doors.
- x **DO NOT** get the bench wet or use in damp or wet locations or areas where there is condensation.
- x **DO NOT** clean the bench with any solvents which may damage the paint surface or the protective coating on the wooden top.

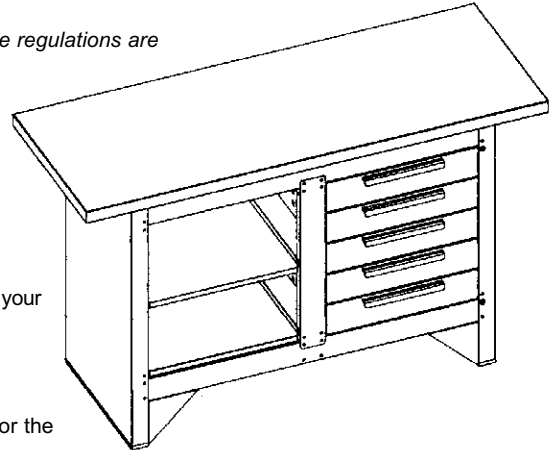

2. CONTENTS

- 2.0 Carefully unpack the product and check the contents against the diagram below. Should any items be missing or damaged make immediate contact with your Sealey dealer.

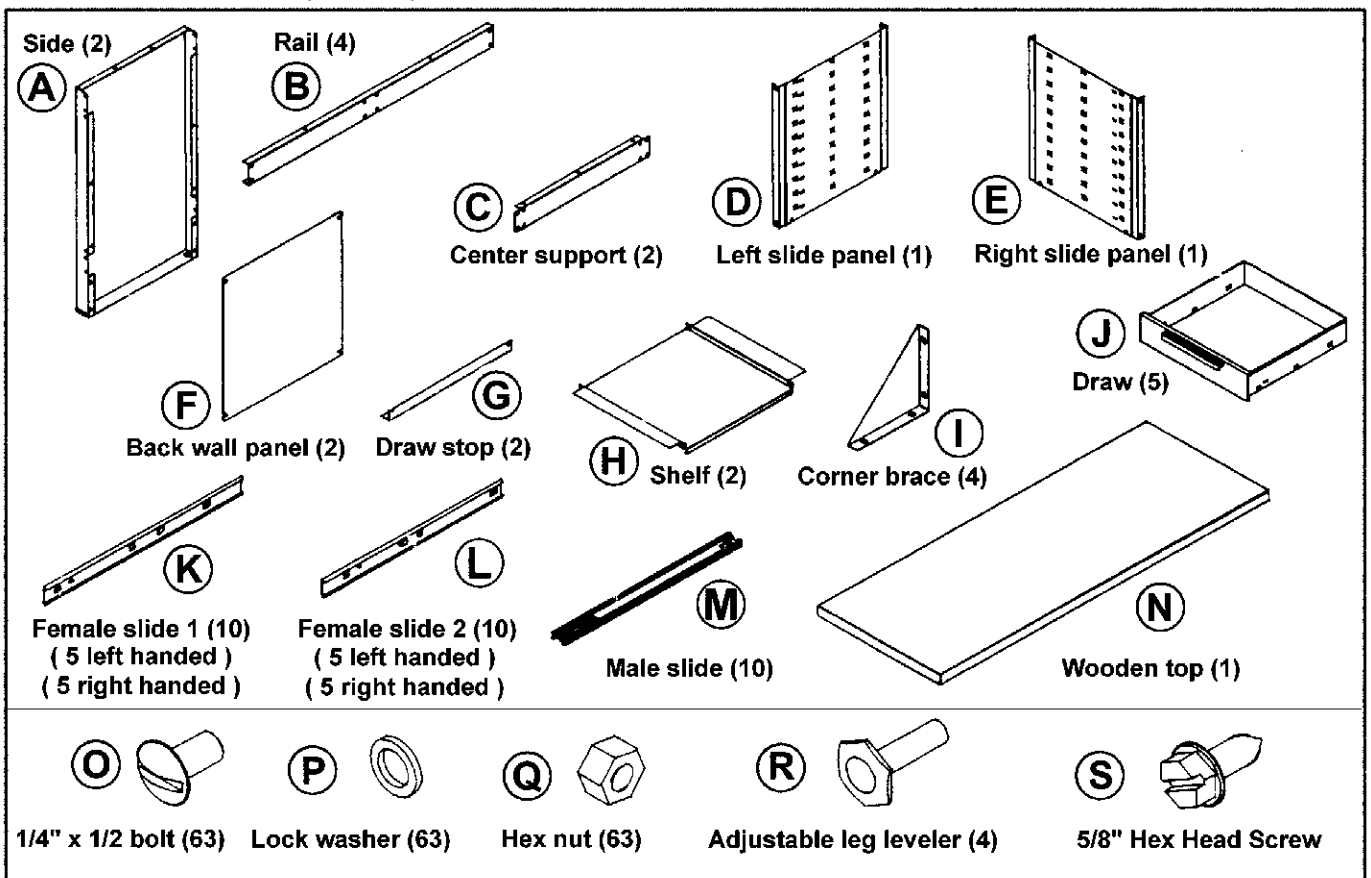

NOTE: It is our policy to continually improve products and as such we reserve the right to alter data, specifications and component parts without prior notice.
IMPORTANT: No liability is accepted for incorrect use of product. **WARRANTY:** Guarantee is 12 months from purchase date, proof of which will be required for any claim. **INFORMATION:** Call us for a copy of our latest catalogue on 01284 757525 and leave your full name and address including your postcode.

3. ASSEMBLY

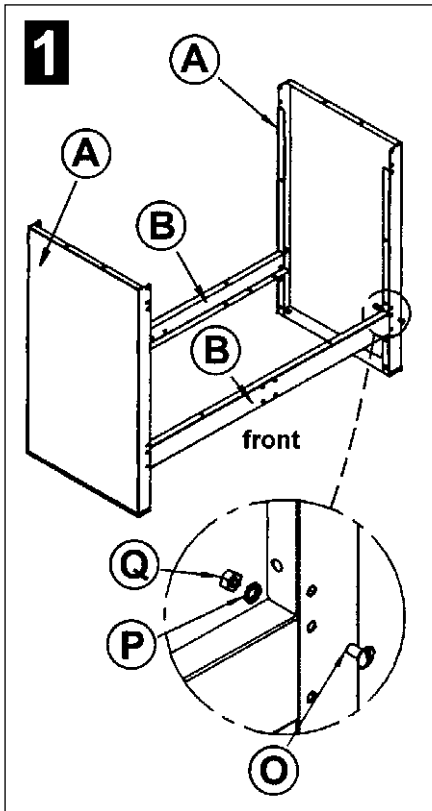

STEP 1. Take two crossrails (B) and bolt them to the cabinet sides (A) using 8 bolts (O), 8 lock washers (P), and 8 nuts (Q). Ensure that the pairs of holes that accept the corner braces are facing downwards. (Refer to STEP 7.)

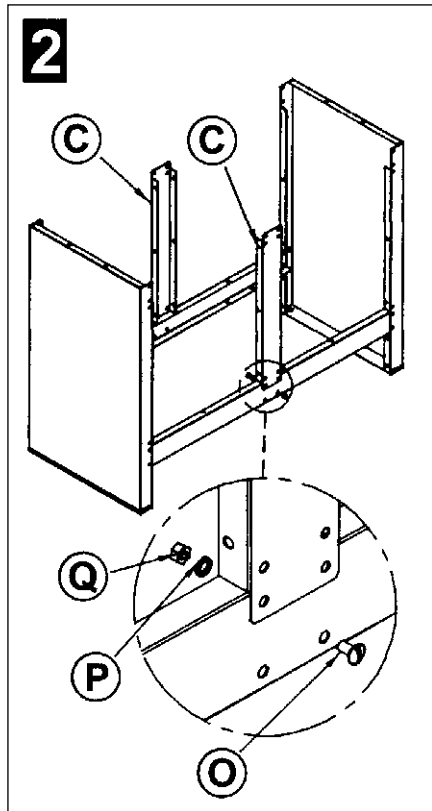

STEP 2. Bolt the two centre supports (C) to the front and back crossrails respectively using 4 bolts (O), 4 lock washers (P), and 4 nuts (Q).

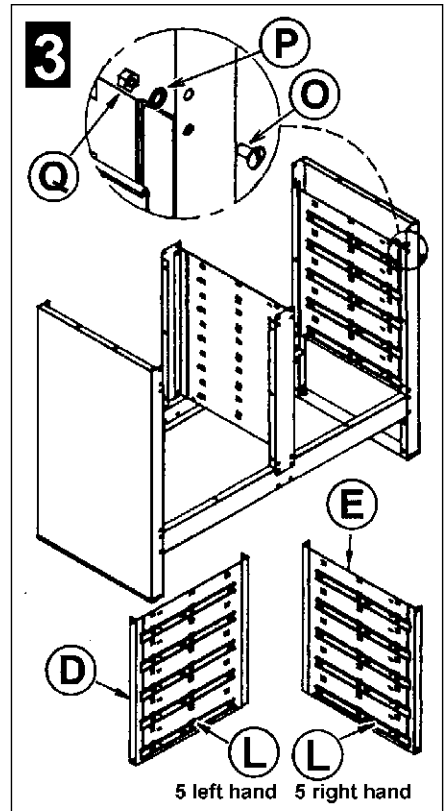

STEP 3. Bolt left & right slide panels (D) & (E) into position using 8 bolts (O), 8 lock washers (P), and 8 nuts (Q). Fix 5 left hand female slides (L), onto slide panel (D) and 5 right hand female slides (L), onto slide panel (E)
Refer to Diagram 11 on how to fit slides.

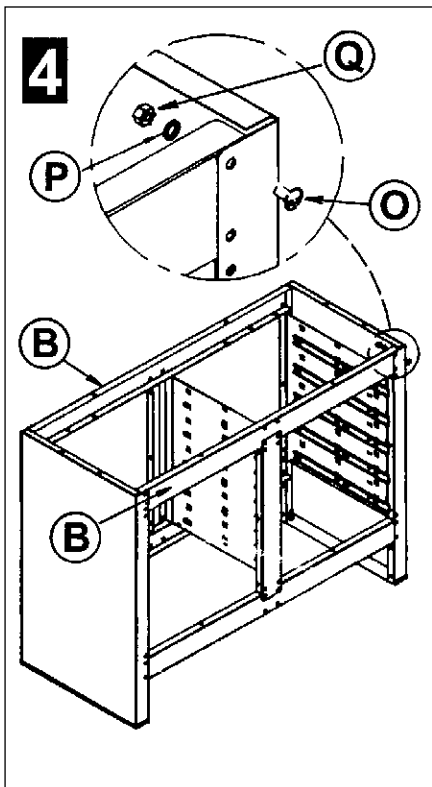

STEP 4. Take two crossrails (B) and bolt them to the cabinet sides (A) and centre supports (C) using 12 bolts (O), 12 lock washers (P), and 12 nuts (Q).

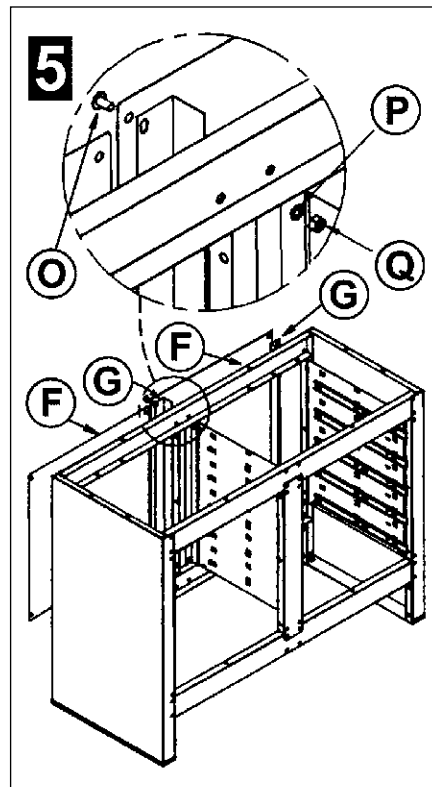

STEP 5. Take the two draw stops (G) and one back panel (F) and bolt them to the back of the cabinet with the draw stops between the panel and the cabinet. Bolt the other back wall panel into position using bolts (O), lock washers (P), and nuts (Q).

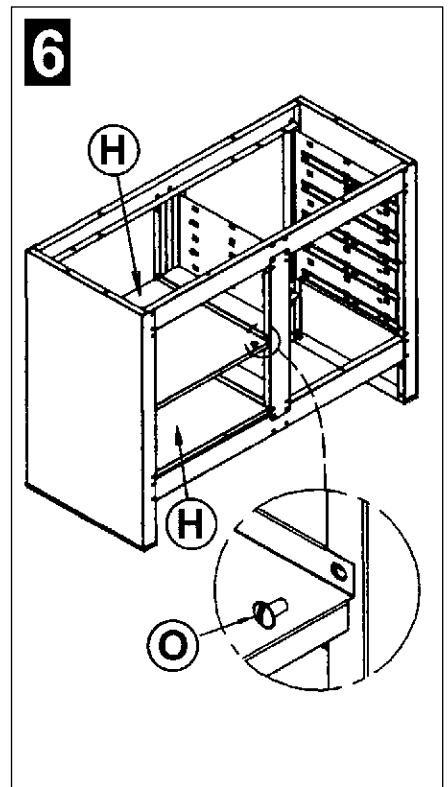

STEP 6. Bolt the two shelf components (H) into position in the left hand compartment using 8 bolts (O), 8 lock washers (P), and 8 nuts (Q).

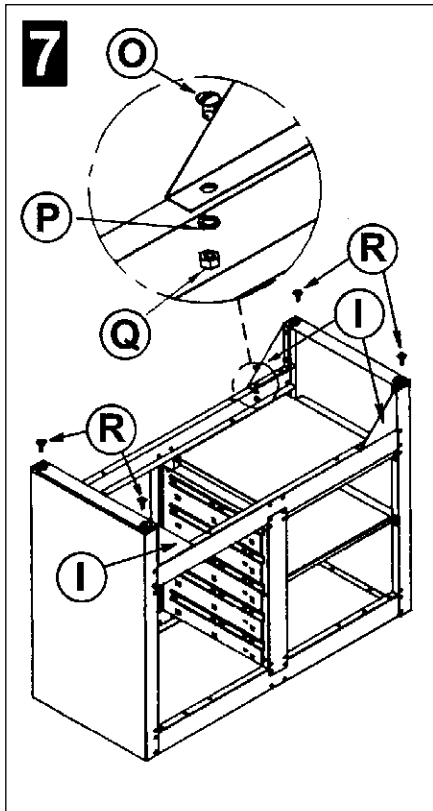

STEP 7. Turn the cabinet upside down and screw in the four adjustable leg levellers (R). Bolt the four corner braces (I) into position using 16 bolts (O), 16 lock washers (P), and 16 nuts (Q)

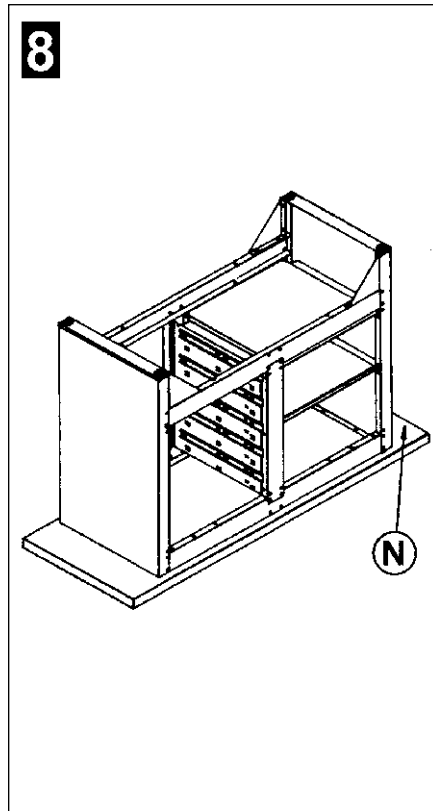

STEP 8. Place the wooden top (N) face down on a flat, clean, smooth surface. Place the cabinet upside down on the wooden top and align it with the four pre-drilled holes. Fix with the four hex head screws (S).

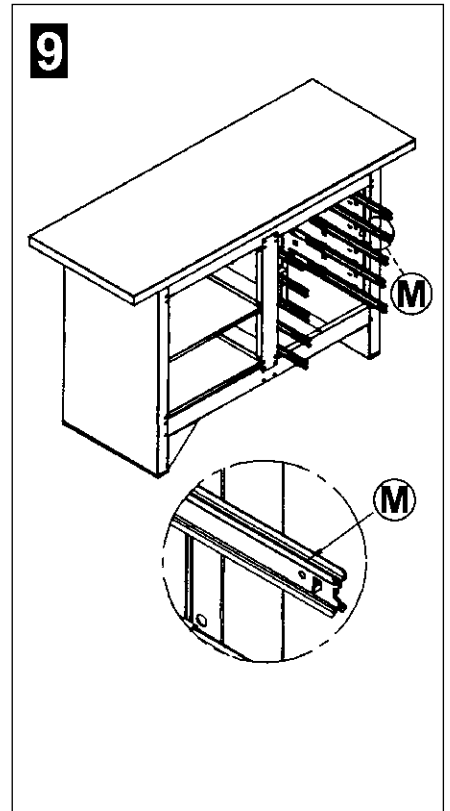

STEP 9. Take the 10 male slide components (M) and slide 5 onto the female slides on the left of the draw compartment and 5 onto the female slides on the right hand side of the draw compartment. Push them fully in to engage them, then pull them out to the stop point.

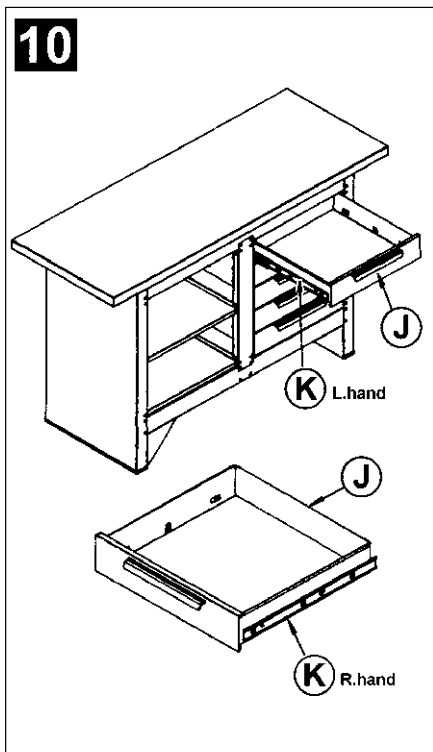

STEP 10. Attach a left hand female slide (K) to left hand side of each draw and a right hand female slide (K) to the right hand side of each draw (see diagram 11). Engage each draw onto the protruding male slides and push fully home, then open the draw to check that it is retained.

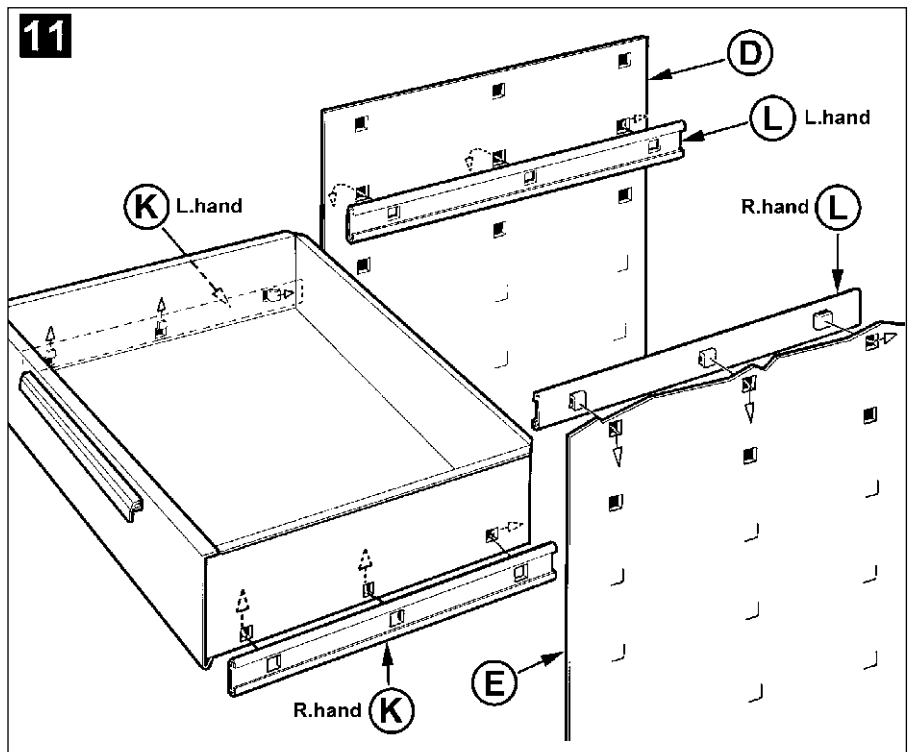

Diagram 11. Orientate each slide as shown in the diagram above with the rear hook pointing towards the rear of the draw or the rear of the cabinet. Put the rear hook on each slide into the square hole nearest the back of the draw or the back of the cabinet and push the slide backwards to engage the hook. Swivel the front of the slide up or down slightly until the other two hooks appear in the other two holes. Keep the rear face of the slide up against the draw or slide panel. On the draws pull the slide sharply upwards to engage it. On the cabinet push the slides down to engage.