

INSTRUCTIONS FOR: ELECTRONIC BATTERY CHARGERS

AUTOCHARGE6.V4

AUTOCHARGE9

AUTOCHARGE12.V4

Thank you for purchasing a Sealey product. Manufactured to a high standard this product will, if used according to these instructions and properly maintained, give you years of trouble free performance.



IMPORTANT: PLEASE READ THESE INSTRUCTIONS CAREFULLY. NOTE THE SAFE OPERATIONAL REQUIREMENTS, WARNINGS & CAUTIONS. USE THE PRODUCT CORRECTLY AND WITH CARE FOR THE PURPOSE FOR WHICH IT IS INTENDED. FAILURE TO DO SO MAY CAUSE DAMAGE AND/OR PERSONAL INJURY AND WILL INVALIDATE THE WARRANTY. PLEASE KEEP INSTRUCTIONS SAFE FOR FUTURE USE.

1. SAFETY INSTRUCTIONS

1.1. ELECTRICAL SAFETY

WARNING! It is the responsibility of the owner and the operator to read, understand and comply with the following:

You must check all electrical products, before use, to ensure that they are safe. You must inspect power cables, plugs, sockets and any other connectors for wear or damage. You must ensure that the risk of electric shock is minimised by the installation of appropriate safety devices. A Residual Current Circuit Breaker (RCCB) should be incorporated in the main distribution board. We also recommend that a Residual Current Device (RCD) is used. It is particularly important to use an RCD with portable products that are plugged into a supply which is not protected by an RCCB. If in any doubt consult a qualified electrician. You may obtain a Residual Current Device by contacting your Sealey dealer. **You must** also read and understand the following instructions concerning electrical safety.

1.1.1. The **Electricity at Work Act 1989** requires all portable electrical appliances, if used on business premises, to be tested by a qualified electrician, using a Portable Appliance Tester (PAT), at least once a year.

1.1.2. The **Health & Safety at Work Act 1974** makes owners of electrical appliances responsible for the safe condition of those appliances and the safety of the appliance operators. **If in any doubt about electrical safety, contact a qualified electrician.**

1.1.3. Ensure that the insulation on all cables and on the appliance is safe before connecting it to the power supply. See 1.1.1. and 1.1.2. and use a Portable Appliance Tester.

1.1.4. Ensure that cables are always protected against short circuit and overload.

1.1.5. Regularly inspect power supply cables and plugs for wear or damage and check all connections to ensure that none is loose.

1.1.6. **Important:** Ensure that the voltage marked on the appliance matches the power supply to be used and that the plug is fitted with the correct fuse - see fuse rating at right.

1.1.7. **DO NOT** pull or carry the appliance by the power cable.

1.1.8. **DO NOT** pull the plug from the socket by the cable.

1.1.9. **DO NOT** use worn or damaged cables, plugs or connectors. Immediately have any faulty item repaired or replaced by a qualified electrician. When an ASTA/BS approved UK 3 pin plug is damaged, cut the cable just above the plug and **dispose of the plug safely**. Fit a new plug according to the following instructions (UK only).

a) **Connect the GREEN/YELLOW earth wire to the earth terminal 'E'.**

b) **Connect the BROWN live wire to the live terminal 'L'.**

c) **Connect the BLUE neutral wire to the neutral terminal 'N'.**

d) **After wiring, check that there are no bare wires, that all wires have been correctly connected, that the cable outer insulation extends beyond the cable restraint and that the restraint is tight.**

Double insulated products, which are always marked with this symbol , are fitted with live (brown) and neutral (blue) wires only. To rewire, connect the wires as indicated above - **DO NOT** connect either wire to the earth terminal.

1.1.10. Products which require more than 13 amps are supplied without a plug. In this case you must contact a qualified electrician to ensure that a suitably rated supply is available. We recommend that you discuss the installation of an industrial round pin plug and socket with your electrician.

1.1.11. If an extension reel is used it should be fully unwound before connection. A reel with an RCD fitted is preferred since any appliance plugged into it will be protected. The cable core section is important and should be at least 1.5mm², but to be absolutely sure that the capacity of the reel is suitable for this product and for others which may be used in the other output sockets, we recommend the use of 2.5mm² section cable. If extension reel is to be used outdoors, ensure it is marked for outdoor use.

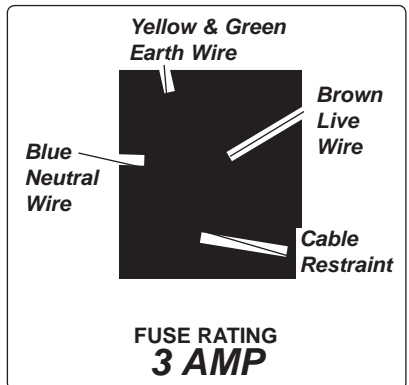

DANGER! BE AWARE, LEAD-ACID BATTERIES GENERATE EXPLOSIVE GASES DURING NORMAL BATTERY OPERATION. FOR THIS REASON, IT IS VERY IMPORTANT TO READ AND FOLLOW THESE INSTRUCTIONS CAREFULLY, EACH TIME YOU USE THE CHARGING EQUIPMENT.

Follow these instructions and those published by the battery and vehicle manufacturers, and the maker of any equipment you intend to use in the vicinity of the battery. Remember to review warning marks on all products and on engines.

1.2. PERSONAL PRECAUTIONS

- ✓ Ensure there is another person within hearing range of your voice and close enough to come to your aid, should a problem arise when working near a lead-acid battery.
- ✓ Wear safety eye protection and protective clothing. Avoid touching eyes while working near battery.
- ✓ Have fresh water and soap nearby in case battery acid contacts skin, clothing or eyes.
- ✓ Wash immediately with soap and water if battery acid contacts skin or clothing. If acid enters eye, flush eye immediately with cool, clean running water for at least 15 minutes and seek immediate medical attention.
- ✓ Remove personal metallic items such as rings, bracelets, necklaces and watches. A lead-acid battery can produce a short-circuit current which is high enough to weld a ring or the like to metal, which would cause severe burns.
- ✓ Ensure hands, clothing (especially belts) are clear of fan blades and other moving or hot parts of engine, remove ties and contain long hair.
- x **DO NOT** smoke or allow a spark or flame in the vicinity of battery or engine.



1.3. GENERAL SAFETY INSTRUCTIONS

- ✓ Familiarise yourself with the application and limitations of the charger as well as the potential hazards. Also refer to the vehicle manufacturer's hand book. **IF IN ANY DOUBT CONSULT A QUALIFIED ELECTRICIAN.**
- ✓ Ensure the charger is in good order and condition before use. If in any doubt do not use the unit, contact your Sealey Dealer.
- ✓ Only use recommended parts. The use of unauthorised parts may be dangerous and will invalidate your warranty.
- ✓ Use the charger in the upright position only and ensure it is placed on a stable surface which will adequately support its weight.
- ✓ Ensure the charger is disconnected from the mains supply before attaching/detaching the power clamps to/from the battery.
- ✓ Keep tools and other items away from the engine and ensure you can see the battery and working parts of engine clearly.

- ✓ Ensure the output of the charger is the same voltage as the battery.
- ✓ If battery has caps to access the battery fluid, remove the caps and check the fluid level before connecting the power clamps. If necessary top-up the battery with distilled water by referring to the battery manufacturer's instructions (Apply the personal safety precautions described in part 1.2).
- ✓ If the charger receives a sharp knock or blow the unit must be checked by a qualified service agent before using.
- ✓ If the battery terminals are corroded or dirty clean them before attaching the power clamps.
- ✓ Keep children and unauthorised persons away from the working area.
- ✗ **DO NOT** dis-assemble the charger for any reason. The charger must only be checked by qualified service personnel.
- ✗ **DO NOT** try to charge a non-rechargeable battery.
- ✗ **DO NOT** try to start engine when charger is connected to battery.
- ✗ **DO NOT** try to charge battery if battery fluid is frozen.
- ☐ **WARNING!** To prevent the risk of sparking, short circuit and possible explosion **DO NOT** drop metal tools in the battery area, or allow them to touch the battery terminals.
- ✗ **DO NOT** allow power clamps to touch each other or to make contact with any metallic part of the vehicle.
- ✗ **DO NOT** cross connect power leads from charger to battery. Ensure positive (+/RED) is to positive and negative (-/BLACK) is to negative.
- ✗ **DO NOT** pull the cables or clamps from the battery terminals.
- ✗ **DO NOT** use the charger outdoors, or in damp, or wet locations and **DO NOT** operate within the vicinity of flammable liquids or gases.
- ✗ **DO NOT** use charger inside vehicle or inside engine compartment.
- ✓ Ensure there is effective ventilation to prevent a build-up of explosive gases, and do not cover or obstruct charger ventilation louvres.
- ✗ **DO NOT** use the charger for a task for which it is not designed.
- ☐ **WARNING! DO NOT** simultaneously charge batteries of different capacities or discharge levels.
- ☐ **WARNING!** If a fuse blows, ensure it is replaced with an identical fuse type and rating. Use only Sealey genuine parts.
- ✓ When not in use, store the charger carefully in a safe, dry, childproof location.

2. INTRODUCTION & SPECIFICATIONS

2.1. Introduction

Compact electronic battery chargers with pressed steel casings and carrying handle. Intelligent charge control and selectable slow or fast charge output make these units perfect for long term maintenance of batteries on irregularly or seasonally used vehicles. Autocharge 12 additionally has selectable 6V or 12V charging. Suitable for lead-acid or low maintenance batteries, the chargers react continuously to battery condition and deliver whatever charge rate is required. Reverse polarity protection prevents inadvertent damage to charger. LED indicators confirm the status of the charger and an analogue ammeter gives an accurate indication of charge rate. These electronic chargers can be connected to a battery for an indefinite period - the intelligent circuitry constantly monitoring the voltage and maintaining the charge level at optimum.

2.2. Specifications

Model No:	AUTOCHARGE6	AUTOCHARGE9	AUTOCHARGE12
Output:	12Vdc	12Vdc	6V/12Vdc
Output Current Peak(EN):	6A(2/4.3A)	9A(2/6.5A)	12A(2/8A)
Input:	230V 50Hz 80W	230V 50Hz 130W	230V 50Hz 170W
Battery Range:	10-60Ah	20-100Ah	20-120Ah

3. OPERATION

- ☐ **WARNING!** Ensure you read, understand and apply the safety and operational instructions before connecting the charger power clamps to the battery. Only when you are sure that you understand the procedures is it safe to proceed with the actual charging process.

Note: This electronic charger can be connected to a battery for an indefinite period - the intelligent circuitry constantly monitoring the voltage and maintaining the charge level at optimum.

Note: These units are fitted with a Thermal Fuse which will switch the charger off if the battery draws too large a current for too long a period of time or in the event of high ambient temperature. Should this occur the unit must be returned to your local dealer for re-setting.

3.1. FRONT PANEL FACILITIES.

(See Fig.1)

Ammeter: When the unit is plugged in to the mains supply and connected to a battery the ammeter indicates the level of charge being delivered to the battery. Where a battery is in a low state of charge the needle will be over to the right (or in the red zone). As charging continues the needle will move to the left to '0' (or be in the green zone) indicating that the battery is fully charged).

Charging Rate Switch:

Choose between trickle or fast rate charging by sliding the switch towards the appropriate LED which will illuminate.

Charge Status LED: This is a dual colour LED. Whilst the battery is charging it is red. When the battery has reached full charge the LED will turn green.

Warning LEDs: Should an overload occur the 'OVERLOAD' LED will illuminate red. If the polarity is reversed (i.e. the battery clamps have been put onto the wrong terminals) the 'REVERSE' LED will illuminate red. **If either condition occurs, immediately unplug the charger.** Do not reconnect the charger until the reason for the condition has been understood and resolved.

Voltage Selection Switch: Choose between 6 and 12 volt charging. (Only available on Autocharge12).

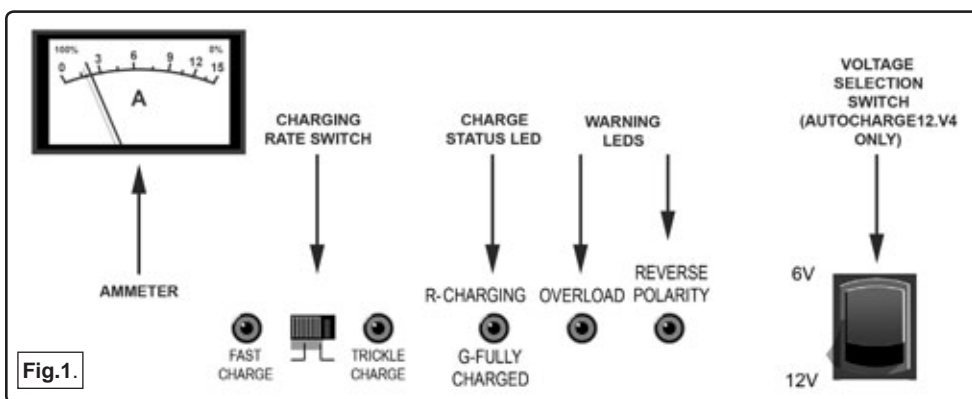

3.2. BATTERY CHARGING:

- ❑ **WARNING!** Ensure you read, understand and follow all safety instructions in Section 1 before attempting to use the AUTOCHARGE6, AUTOCHARGE9 or AUTOCHARGE12.
- ❑ **WARNING!** It is advised before charging, to disconnect and remove the battery from the vehicle to prevent damage to sensitive onboard equipment. Remember to provide a back-up supply for onboard electronics and to retain any security codes. Check Sealey Model No. VS207 for this function.



NOTE: FOR A VERY FLAT BATTERY, DISCONNECT CABLES FROM BATTERY TERMINALS AND ALLOW BATTERY TO REST FOR 30 MINUTES BEFORE ATTEMPTING TO CHARGE.



- 3.2.1. AUTOCHARGE6 and AUTOCHARGE9 can only be used to charge 12V batteries. Check the voltage of the battery is 12V before commencing charging.
 - 3.2.2. AUTOCHARGE12 can be used to charge 6V and 12V batteries. Before connecting to the battery or to the mains supply check the voltage of the battery and set the voltage selection switch to the appropriate value.
 - 3.2.3. If the battery is not a sealed unit, remove the filler caps and check the level of the electrolyte. If it is below the recommended level, top up using distilled water. **Do not** use tap water under any circumstances. To prevent acid splashing during the charging process, replace the filler caps but do not tighten them, allowing gases to escape.
 - 3.2.4. If sealed unit, it is unnecessary to carry out the checks outlined in 3.2.3.
 - 3.2.5. Connect power clamps to the battery terminals, ensuring correct polarity.
 - 3.2.6. The charging rate switch should be set to trickle for an effective charge and long term battery life. The fast charge option is for situations where rapid charging is imperative.
 - 3.2.7. Plug the charger into the mains power supply. The charge status LED should now be illuminated red and the ammeter needle over to the right.
 - 3.2.8. When the charge status LED turns to green the battery is fully charged and the ammeter needle should be over to the left.
 - 3.2.9. Unplug the unit from the mains before removing the clamps from the battery.
 - 3.2.10 Carefully wipe any spillage of acid from the battery top and replace battery caps, if removed.
 - 3.2.11 For long term maintenance of batteries on irregularly or seasonally used vehicles the charger can be connected to a battery for an indefinite period - the intelligent circuitry constantly monitoring the voltage and maintaining the charge level at optimum.
- NOTE: If left on charge this way, you must check the battery's electrolyte level at regular intervals.**



NOTE: It is our policy to continually improve products and as such we reserve the right to alter data, specifications and component parts without prior notice.

IMPORTANT: No liability is accepted for incorrect use of this product.

WARRANTY: Guarantee is 12 months from purchase date, proof of which will be required for any claim.

INFORMATION: For a copy of our latest catalogue and promotions call us on 01284 757525 and leave your full name and address, including postcode.



Sole UK Distributor, Sealey Group,
Kempson Way, Suffolk Business Park,
Bury St. Edmunds, Suffolk,
IP32 7AR



01284 757500



www.sealey.co.uk



01284 703534



sales@sealey.co.uk