

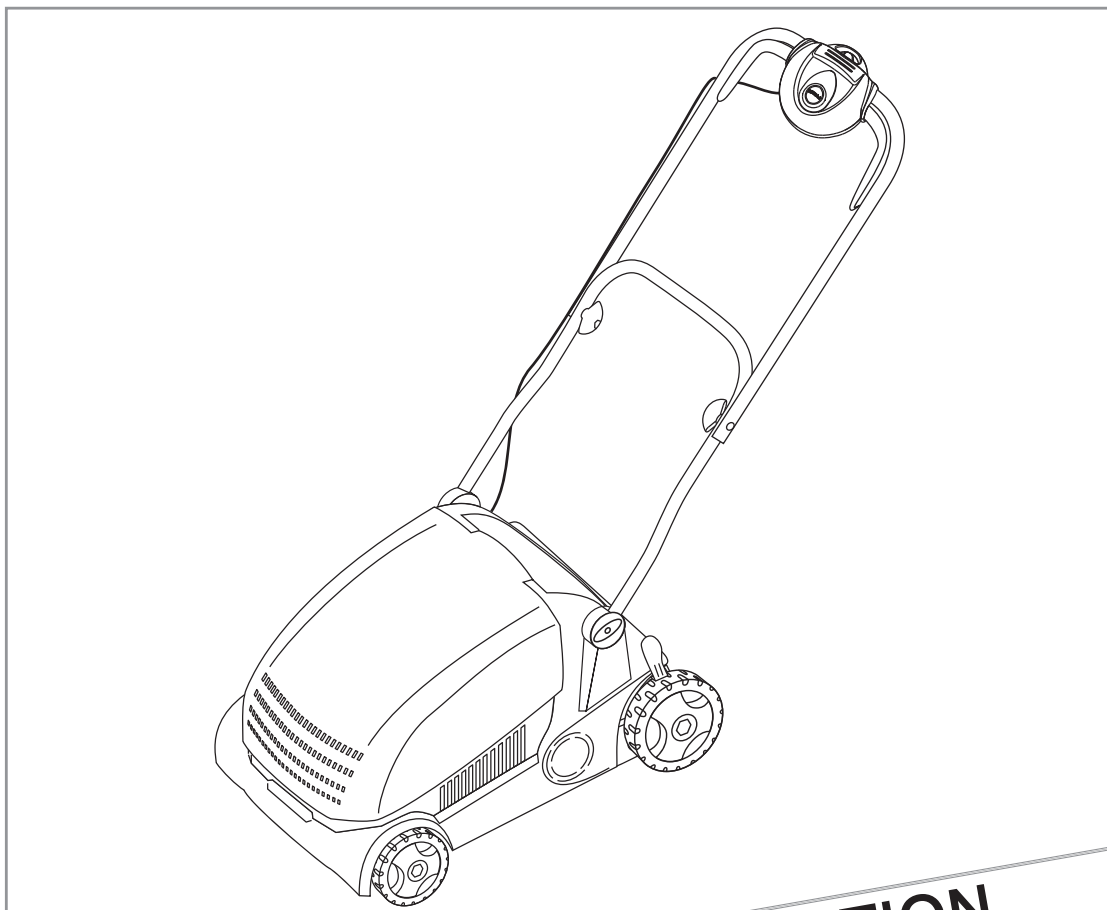

Lawnrake



Original Instructions



IMPORTANT INFORMATION
Read before use
& retain for future reference

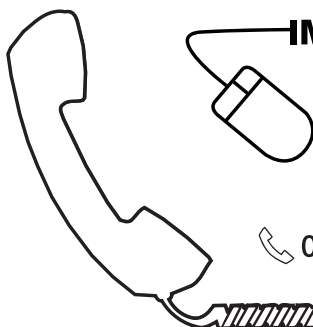

IMPORTANT Please register your product warranty on line.

To register your warranty and for all your parts requirements please visit

www.flymo.com

For all other enquiries

0844 844 4558 **UK** 1800 882 350 **ROI**

customer.services@husqvarna.co.uk

Carton Contents

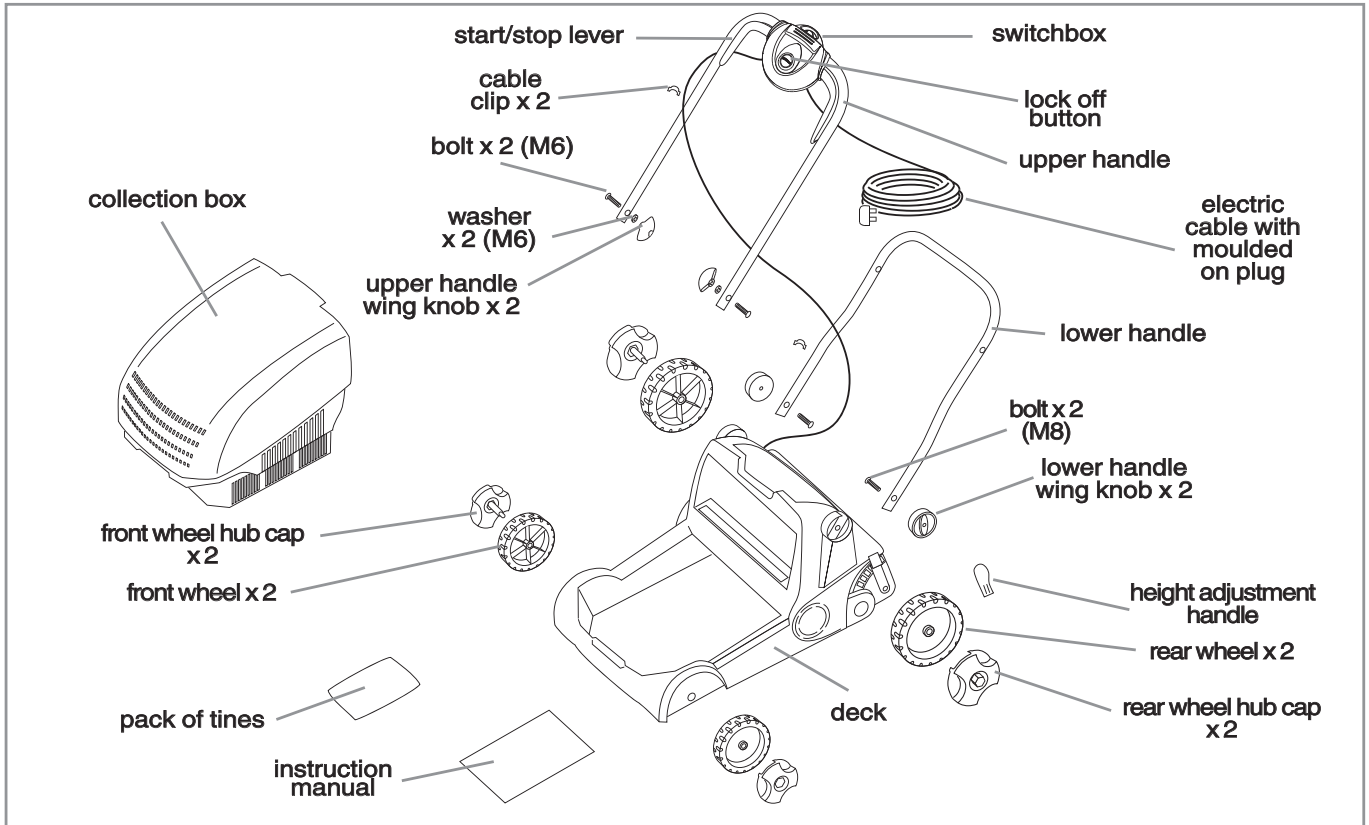

IMPORTANT ! Please check the contents of the carton are correct **BEFORE** assembling your new product. **IF ANY PARTS ARE MISSING CONTACT:-**

Husqvarna UK Ltd. Customer Service Department direct

Telephone : 0844 844 4558 UK

1800 882 350 ROI

Fax : 01325 302530

Safety



If not used properly this product can be dangerous! This product can cause serious injury to the operator and others, the warnings and safety instructions must be followed to ensure reasonable safety and efficiency in using this product. The operator is responsible for following the warning and safety instructions in this manual and on the product. Never use the product unless the grassbox or guards provided by the manufacturer are in the correct position.

Explanation of Symbols on your product



Warning



Read the user instructions carefully to make sure you understand all the controls and what they do.



Always keep the product on the ground when using. Tilting or lifting the product may cause stones to be thrown out.

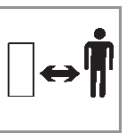

Keep bystanders away. Do not use whilst people especially children or pets are in the raking area.



Beware of sharp tines. Tines continue to rotate after the motor is switched off - remove plug from mains before maintenance or if cable is damaged.



Keep the cable supply away from the tines.

General

1. This product is not intended for use by persons (including children) with reduced physical, sensory or mental capabilities, or lack of experience and knowledge, unless they have been given supervision or instruction concerning the use of the product by a person responsible for their safety. Children should be supervised to ensure that they do not play with the product. Local regulations may restrict the age of the operator.
2. Never allow children or people unfamiliar with the instructions to use the machine.
3. Stop using the machine while people, especially children, or pets are nearby.
4. Only use the product in the manner and for the functions described in these instructions.
5. Never operate the product when you are tired, ill or under the influence of alcohol, drugs or medicine.
6. The operator or user is responsible for accidents or hazards occurring to other people or their property.

Electrical

1. We recommend the use of a Residual Current Device (R.C.D.) with a tripping current of not more than 30mA. Even with a R.C.D. installed 100% safety cannot be guaranteed and safe working practice must be followed at all times. Check your R.C.D. every time you use it.
2. Before use, examine the cable for signs of damage or ageing. If the cable is found to be defective, take the product to an Authorised Service Centre and have the cable replaced.
3. Do not use the product if the electric cables are damaged or worn
4. Immediately disconnect from the mains electricity supply if the cable is cut, or the insulation is damaged. Do not touch the electric cable until the electrical supply has been disconnected. Do not repair a cut or damaged cable. Replace it with a new one.
5. Your cable must be uncoiled or unwound, coiled or wound cables can overheat and reduce the efficiency of your mower.
6. Keep cable away from the tines. The tines can cause damage to the cable and lead to contact with live parts. Always work away from the power point, operating up and down, never in circles.
7. Do not pull cable around sharp objects.
8. Always switch off at the mains before disconnecting any plug, cable connector or extension cable.
9. Switch off, remove plug from mains and examine electric supply cable for damage or ageing **before** winding cable for storage. Do not repair a damaged cable, replace it with a new one. Use only our replacement cable.
10. Always wind cable carefully, avoiding kinking.
11. Never carry the product by the cable.
12. Never pull on the cable to disconnect any of the plugs.
13. Use only on AC mains supply voltage shown on the product rating label.
14. Our products are double insulated to EN60335. Under no circumstance should an earth be connected to any part of the product.

Preparation

1. While using your product always wear substantial footwear and long trousers. Do not operate the equipment when barefoot or wearing open toe sandals.
2. Make sure the lawn is clear of sticks, stones, bones, wire and debris; they could be thrown by the tines.
3. Before using the machine and after any impact, check for signs of wear or damage and repair as necessary.

4. Replace worn or damaged tines.

Use

1. Use the product only in daylight or good artificial light.
2. Avoid operating your product in wet grass, where feasible.
3. Take care in wet grass, you may lose your footing.
4. On slopes, be extra careful of your footing and wear non-slip footwear.
5. Use across the face of slopes, never up and down.
6. Exercise extreme caution when changing direction on slopes. Walk never run.
7. Operating on banks and slopes can be dangerous. Do not operate on **banks** or **steep** slopes.
8. Do not walk backwards when operating, you could trip.
9. Use extreme caution when pulling the product towards you.
10. Switch off before pushing the product over surfaces other than grass.
11. Never operate the product with damaged guards or without guards in place.
12. Keep hands and feet away from the cutting means at all times and especially when switching on the motor. Danger - Do not touch rotating tines.
13. Do not touch the tines before the machine is disconnected from the mains and the tines have to come to a complete stop.
14. Do not tilt the product when the motor is running, except when starting and stopping. In this case, do not tilt more than absolutely necessary and lift only the part which is away from the operator. Always ensure that both hands are in the operating position before returning the appliance to the ground.
15. Never pick up or carry the product when it is operating or still connected to the mains supply.
16. Do not put hands or feet near or under rotating parts. Keep clear of the the discharge opening at all times.
17. Remove the plug from the mains :
 - before leaving the product unattended for any period;
 - before clearing a blockage;
 - before checking, cleaning or working on the appliance;
 - if you hit an object. Do not use until you are sure that the entire product is in a safe operating condition.;
 - if the product starts to vibrate abnormally. Check immediately. Excessive vibration can cause injury.

Maintenance and storage

1. Caution - Do not touch rotating tines.
2. Keep all nuts, bolts and screws tight to be sure the product is in safe working condition.
3. Check the collection box frequently for wear or deterioration.
4. Replace worn or damaged parts for safety.
5. Only use the replacement parts specified for this product.
6. Be careful during adjustment of the product to prevent entrapment of the fingers between moving and fixed parts of the machine.
7. Store in a cool dry place and out of reach of children. Do not store outdoors.
8. Allow the product to cool for at least 30 minutes before storing.

Assembly Instructions

CABLES - IMPORTANT

If you want to use an extension cable when operating your product, only the following cable dimensions should be used.

- 1.0 mm² : max length 40 m
- 1.5 mm² : max length 60 m
- 2.5mm² : max length 100 m

Minimum rating :

1.00mm² size cable, 10 amps 250 volts AC.

• YOUR PRODUCT IS SUPPLIED WITH CABLE WIRED DIRECTLY INTO THE PRODUCT.

1. Flymo Mains Cables and Extension Cables are available from your local Husqvarna Outdoor Products Approved Service Centre.
2. Do not wire an extension cable directly to your product yourself. Please contact your local Husqvarna Outdoor Products Approved Service Centre for further information on the connectors and kits available.
3. Only use extension cables specifically designed for outdoor use.

CONNECTORS - IMPORTANT

- Flymo connectors are suitable for use with 2 core cable only. Under no circumstances should these connectors be used for earthed products.
- All Flymo connectors and cables are of splashproof construction. They are not waterproof and must not be left outside permanently nor should they be submerged or immersed in water. Do not let cable lay or trail through pools of water or splashed with water from hose pipes.

MAINS PLUG REPLACEMENT - IMPORTANT

- If the plug supplied is cut off it should be destroyed.

There is an electric shock hazard if a cut off plug is inserted into a 13 amp socket.

1. **No earth required.** Flymo products are double insulated to EN60335 and under no circumstances should an earth be connected to any part of the product.
2. **Ensure the mains voltage suits your product**
3. **IMPORTANT!**
The wires in the mains lead are coloured in accordance with the following code:
BLUE - NEUTRAL BROWN - LIVE
The wire which is coloured BLUE must be connected to the Terminal which is marked with the letter 'N' or coloured BLACK. The wire which is coloured BROWN must be connected to the Terminal which is marked with the letter 'L' or coloured RED.
4. It is important that the outer sheath is clamped correctly into the 3-pin plug.
5. If in doubt consult your local Service Repairer or qualified electrician before the machine is used.
6. **A 13 Amp fuse must be fitted to the Mains Plug.**
7. The normal plug fuse and household fuse only protect the electrical equipment and are not a safeguard against electrocution.

If your product is hard wired i.e. non-detachable mains electric cable, a conversion kit and extension cable is available from all Husqvarna Outdoor Products Approved Service Centres which can be found in your local Yellow Pages.

Assembly Instructions

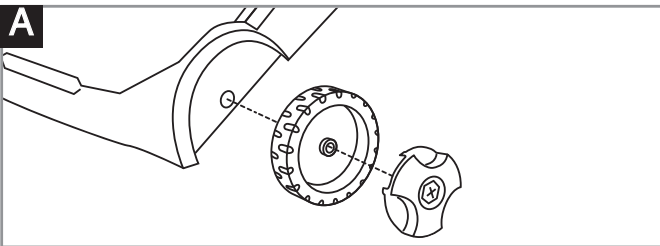

Wheel Assembly (A)

1. Insert the wheel bolt into the threaded hole.
2. Fully tighten the bolts using a screwdriver.

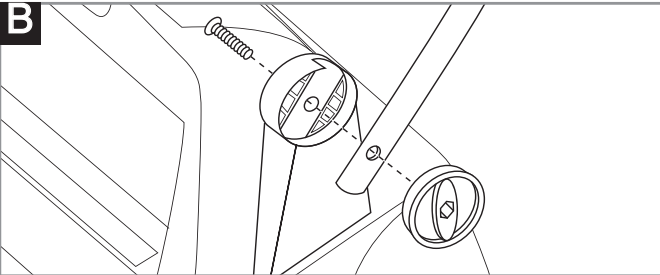

Assembly of Lower Handles to Deck

1. Place the hole in the lower handle over the end of the bolt (B)
2. Place the wing knob onto the end of the bolt and firmly tighten. (B)
3. Repeat on the other side.

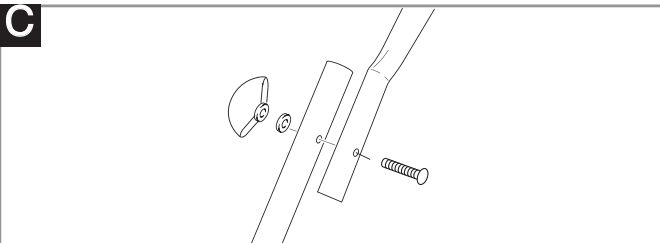

Assembly of Upper Handles to Lower Handles.

1. Ensure the upper handle is located correctly with the lock-off button on the switchbox uppermost.
2. Ensure the upper handle and the lower handle are aligned correctly. (C)
3. Fit the bolts, washers and wing knobs. (C)
4. Fit the cable to the handles with the clips provided. Make sure the cable is not trapped between the upper and lower handles.

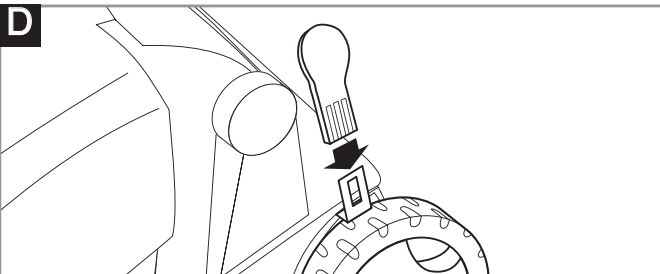

Height Adjust Handle Assembly

1. Insert the height adjust arm into the slot at the base of the height adjust handle (D)
2. Firmly push the handle on to the arm.
3. The handle will automatically lock on to the arm.

Height Adjustment

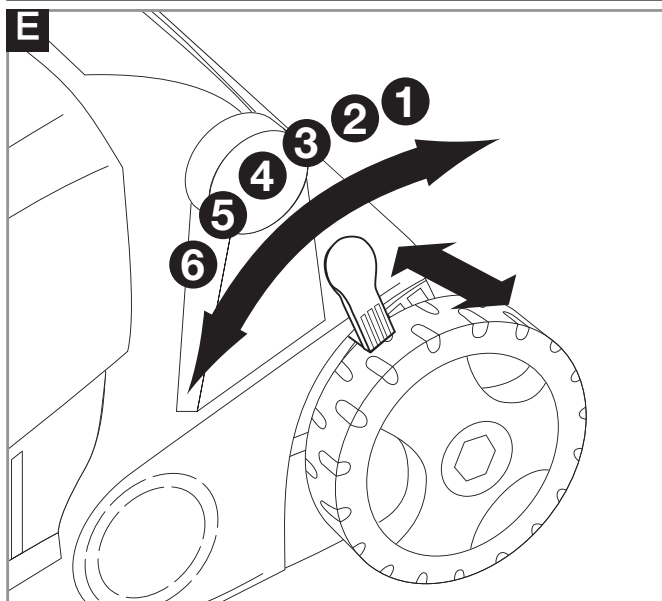

Adjusting the raking height

1. Lift the lever out of location and rotate to the desired position. (E)

Heights of raking:-

1, 2, 3 - low

The low settings should be used to collect material from the base of the lawn. This setting is ideal for removing moss and thatch. After removing the thick patches of moss and thatch the lawn may look bare in some patches. These patches in the lawn will start to recover now that the moss and thatch has been removed.

4, 5 - medium

The medium settings should be used for light raking. This setting is ideal for lifting flattened grass prior to mowing and for collecting grass cuttings after mowing. It can also be used for light raking of moss and thatch.

6 - high

The high setting should be used for clearing the lawn. This setting is ideal for collecting light debris such as fallen leaves, twigs and grass cuttings without damaging the lawn.

Starting and Stopping

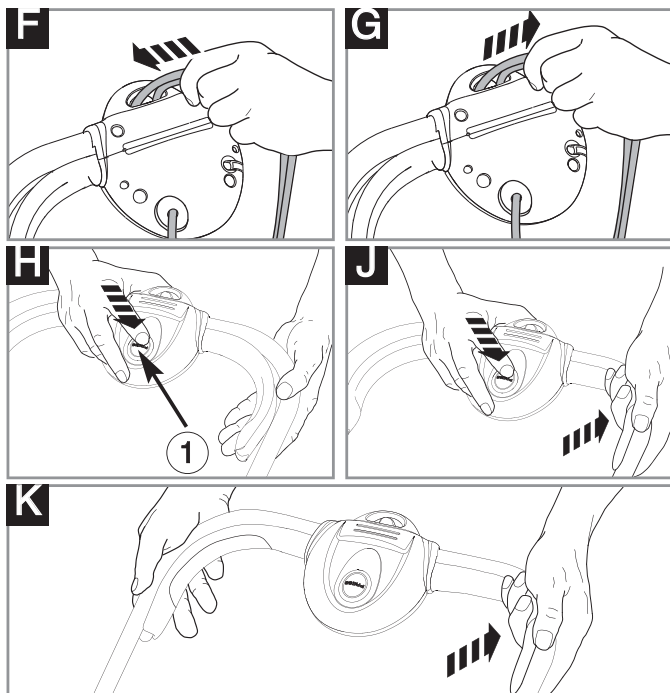

To Start your Product

1. Form loop in mains cable and push the loop through the slot. (F)
2. To secure, position loop over the hook and pull the cable back through the slot (G).
3. Connect plug to mains and switch on.
4. Tilt the handle downwards to slightly raise the front of the product and to reduce the risk of lawn damage whilst starting.

The switchbox is provided with a lock-off button (H1) to prevent accidental starting.

5. Press and hold the lock-off button (H) on the switchbox, then squeeze one of the Start/Stop levers towards the upper handle (J).
6. Continue to squeeze the start/stop lever towards the upper handle and release the lock-off button (K).
7. Lower the product to its proper operating position and commence raking.

- **NOTE** - There are two start/stop levers fitted. Either one can be used for starting the product.
- **IMPORTANT** - Do not use the start/stop levers intermittently

To Stop your Product

1. Release the pressure on the Start/Stop lever.

How to Use

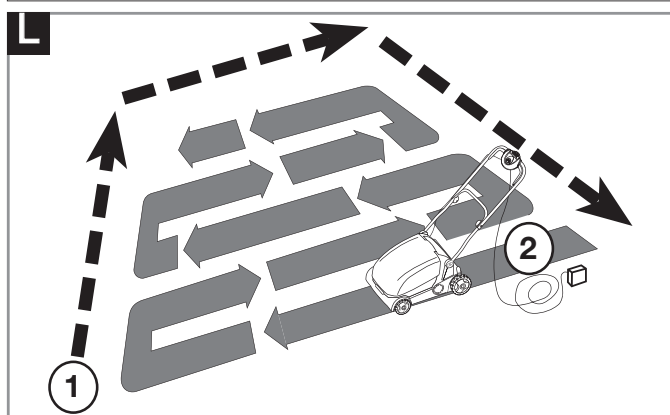

Raking your Lawn

Raking the lawn helps aerate the soil, prevent diseases, it also improves surface drainage and promotes a healthier thicker lawn.

Moss

There are several types of mosses, which can cause problems to your lawn. Moss as well as being detrimental to the appearance of your lawn, will smother grass, make the lawn spongy, make it difficult to mow, hold water and encourage disease. Moss spores are released during spring and autumn.

Thatch

Thatch is decaying organic matter that builds up on the base of the lawn. Like moss thatch is detrimental to the appearance of your lawn and can cause bad surface drainage, encourage weeds, prevent air circulation and encourage disease.

How to Use cont'

How to Use

- Do not use in wet or damp conditions. Raking in wet conditions can damage the lawn.
- Do not force the lawnrake through long grass it should be used on grass no longer than 75mm in length. If the grass is long, mow the lawn prior to using the Lawn Rake. The Lawn Rake can collect your grass clippings while raking.
- Clear the lawn of any loose debris or stones that may damage the lawnrake.
- On your first use choose a medium height to start with, and then adjust the height setting to suit your lawn and use.
- Start the lawnrake at the edge of the lawn, close to the power point, and work away from the power point.

Once you have raked the lawn in one direction rake again at right angles to the previous direction. (L)

- For total control of moss, use moss killer in early spring a couple of weeks prior to using the lawnrake
- To gently remove particularly heavy areas of moss and thatch you may have to rake over the area several times.
- For best results use your lawnrake regularly particularly at the beginning of the season to encourage good growth and at the end of the season to prepare the lawn for winter. The lawn should be raked in autumn leaving some time for the lawn to thicken and recover before winter.
- To maintain the quality of your lawnrake it is recommended that you clean it after use. Refer to the section - Caring for your Product

Collection Box

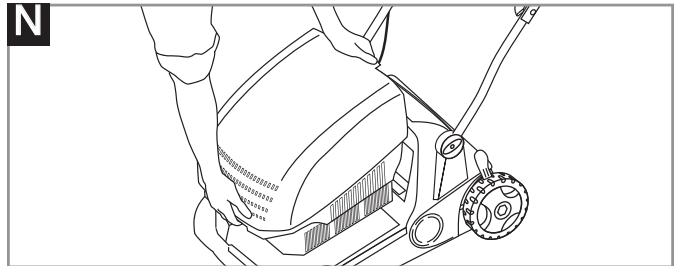
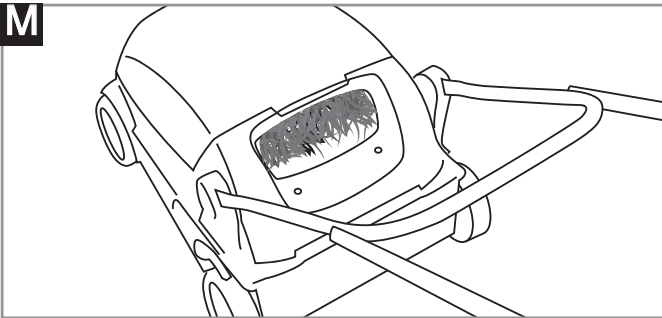

Collection Box Full (M)

1. As the collection box fills up, grass will be clearly visible through the window in the lid (M).
2. When the window is full it is time to empty the collection box.

Emptying the Collection Box

1. Lift the collection box at the front and the rear handles (N)
2. Tilt the collection box upside down to release the collection box flap (P)
3. Empty into your compost or garden waste bin.
4. Ensure collection box flap is fitted correctly before refitting the collection box

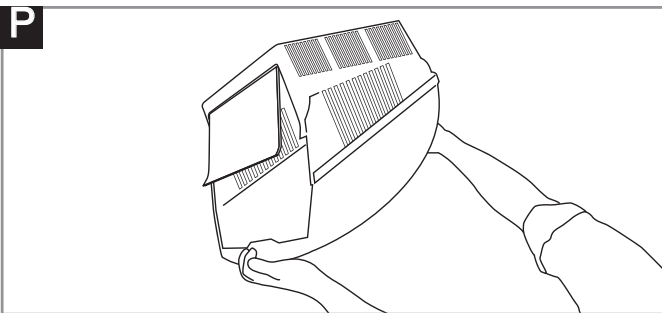

Removing and Fitting the Tines

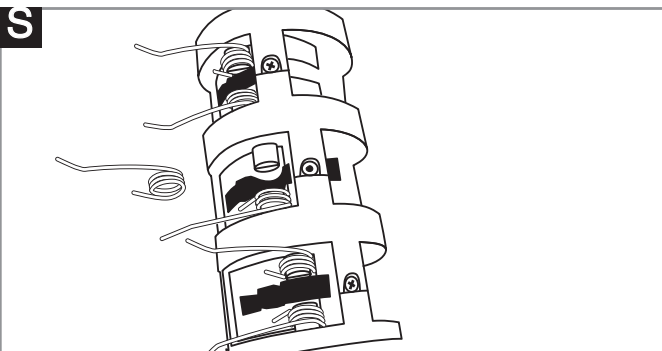
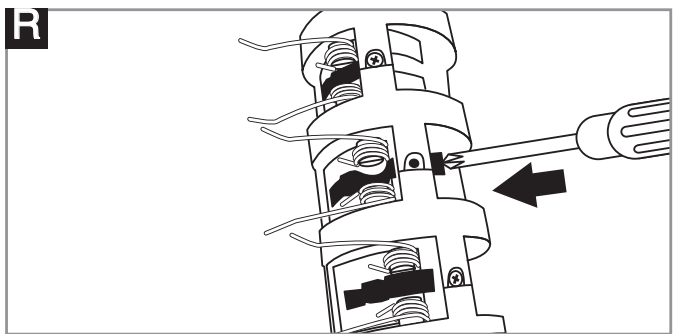
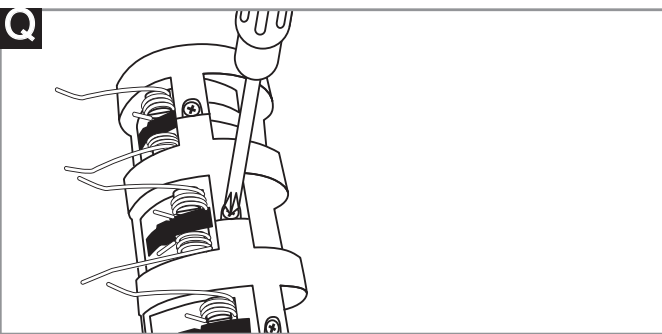

Removing and Fitting the Tines

1. Ensure plug is removed from power supply
2. Turn the lawn rake upside down to access the tines
3. Remove the screw from the central disc on the set of tines you wish to replace (Q)
4. Rotate the central disc to unlock the tines (R)
5. Remove the existing tine and replace with a new one (S)
6. There are 2 types of tine; a left and a right. When replacing a worn tine of one type you should replace it with a new tine of the same type.
7. Fitting is reversal of removal.

Caring for your Product

Cleaning (T)

- **USE GLOVES**
- **IMPORTANT**

It is very important that you keep your product clean. Grass clippings left in any of the air intakes or under the deck could become a potential fire hazard.

1. Remove grass from under the deck with a brush.
2. Using a soft brush - remove grass clippings from all air intakes, the collection box and the vision window
3. Wipe over the surface of your product with a dry cloth.

- **IMPORTANT**

Never use water for cleaning your product. Do not clean with chemicals, including petrol, or solvents - some can destroy critical plastic parts.

At the End of the cutting Season

1. Replace tines, bolts, nuts or screws, if necessary.
2. Clean your product thoroughly.
3. Make sure that the electric cable is coiled properly.

Storing your product: Store in a dry place where your product is protected from damage

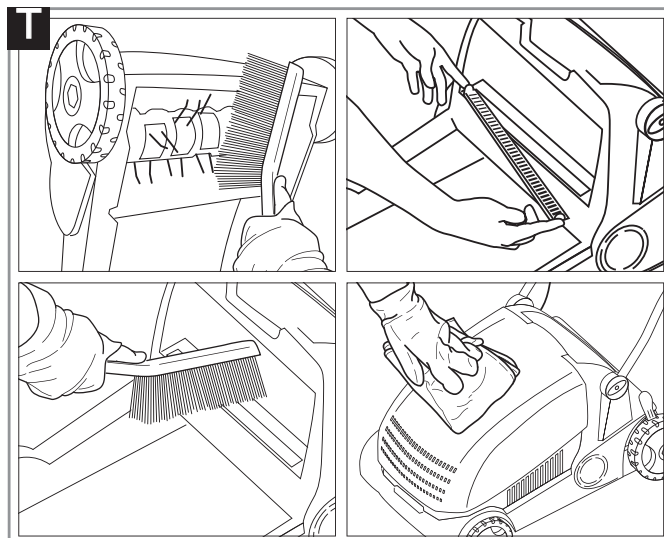

Fault Finding Hints

Fails to Operate

1. Is the correct Starting procedure being followed? See 'To Start your Lawnrake'
2. Is the Power Turned On?
3. Check the fuse in the plug, if blown replace.
4. Fuse continues to blow?

Immediately disconnect from the mains electricity supply and consult your local approved Service Centre.

Poor Collection

1. Disconnect from the mains electricity supply.
2. Clean the outside of the air intakes, the discharge chute and the underside of the deck.
3. Try a different height of rake. See 'Height Adjustment'.
4. Check condition of the Tines and replace if necessary. See 'Removing and Fitting the Tines'.
5. **If poor collection persists.**

Immediately disconnect from the mains electricity supply and consult your local approved Service Centre.

Excessive Vibration

1. Disconnect from the mains electricity supply.
2. Check that the tines are functioning correctly.
3. Replace tines if necessary
4. If vibration persists?

Immediately disconnect from the mains electricity supply and consult your local approved Service Centre.

Lawnrake becomes heavy to push

1. Disconnect from the mains electricity supply.
2. In long grass or uneven ground, the height of cut should be raised to a higher position. See Cutting Height Adjustment.
3. Check that the wheels can rotate freely.
4. If problem persists?

Immediately disconnect from the mains electricity supply and consult your local approved Service Centre.

Service Recommendations

1. We strongly recommend that your product is serviced at least every twelve months, more often in a professional application.
2. Always use genuine Spare Parts.
3. Prepacked spares are available from most Husqvarna UK Ltd. stockists and www.flymo.com.
4. Your product is uniquely identified by a silver and black product rating label
5. If you have a problem with your machine contact your local Approved Service Centre ensuring you have full details of your product as described on the product rating label.

6. **Should it be necessary for work to be carried out by your Service Centre, it is important to take your complete machine including cable and any extension cables used.**

A network of specialist dealers can be found in your local Yellow Pages. To obtain service on your product simply telephone or visit your local Service Centre. Should you require service under the terms of our guarantee the Service Centre will require proof of purchase.

All of the centres listed stock genuine Spare Parts.

NOTE: Our Service Repairers act on their own behalf and are not empowered to commit or legally bind Husqvarna UK Ltd. in any manner whatsoever.

Environmental Information

- Awareness of the environment must be considered when disposing of 'end-of-life' product.
- If necessary, contact your local authority for disposal information.

The symbol  on the product or on its packaging indicates that this product may not be treated as household waste. Instead it shall be handed over to the applicable collection point for the recycling of electrical and electronic

equipment. By ensuring this product is disposed of correctly, you will help prevent potential negative consequences for the environment and human health, which could otherwise be caused by inappropriate waste handling of this product. For more detailed information about recycling of this product, please contact your local council office, your household waste disposal service or the shop where you purchased the product.

Replacement Parts

Metal Tines

Reference no.:

FLY058

Part no.:

504807001

Guarantee & Guarantee Policy

If any part is found to be defective due to faulty manufacture within the guarantee period, Husqvarna UK Ltd., through its Authorised Service Repairers will effect the repair or replacement to the customer free of charge providing:

- The fault is reported directly to the Authorised Repairer.
 - Proof of purchase is provided.
 - The fault is not caused by misuse, neglect or faulty adjustment by the user.
 - The failure has not occurred through fair wear and tear.
 - The machine has not been serviced or repaired, taken apart or tampered with by any person not authorised by Husqvarna UK Ltd..
 - The machine has not been used for hire.
 - The machine is owned by the original purchaser.
 - The machine has not been used commercially.
- * This guarantee is additional to, and in no way diminishes the customers statutory rights.

Failures due to the following are not covered, therefore it is important that you read the instructions contained in this Operator's Manual and understand how to operate and maintain your machine:

Failures not covered by guarantee

- * Replacing worn or damaged tines
- * Failures as a result of not reporting an initial fault.
- * Failures as a result of sudden impact.
- * Failures as a result of not using the product in accordance with the instructions and recommendations contained in this Operator's Manual.
- * Machines used for hire are not covered by this guarantee.
- * The following items listed are considered as wearing parts and their life is dependent on regular maintenance and are, therefore not normally subject to a valid warranty claim:
Tines, Electric Mains cable.
- * **Caution!**
Husqvarna UK Ltd. does not accept liability under the warranty for defects caused in whole or part, directly or indirectly by the fitting of replacement parts or additional parts that are not either manufactured or approved by Husqvarna UK Ltd., or by the machine having been modified in any way.

EC Declaration of Conformity

Husqvarna AB, 561 82, Huskvarna, Sweden

Declare under our sole responsibility that the product(s);

Category.....**Electric Scarifier**
 Type(s)**LRC3400**
 Identification of Series.....**See Product Rating Label**
 Year of Construction.....**See Product Rating Label**

Conforms to the essential requirements & provisions of the following EC Directives:

2006/42/EC, 2004/108/EC, 2000/14/EC

based on the following EU harmonized standards applied:

EN60335-1, EN60335-2-92, EN13684, EN50366, EN55014-1, EN61000-3-2, EN61000-3-3

The maximum A weighted sound pressure level L_{pA} at the operator's position, measured according to EN60335-2-92, corresponds to the **Level** given in the table.

The maximum hand / arm vibration weighted value measured according to EN ISO 20643 on a sample of the above product(s) corresponds to the **Value** a_h given in the table.

2000/14/EC: The Measured Sound Power L_{WA} & Guaranteed Sound Power L_{WA} values are according to the tabulated figures.

Conformity Assessment Procedure..... Annex VI
 Notified Body..... Intertek, Cleeve Road
 Leatherhead, Surrey
 KT22 7SB, England

Newton Aycliffe 26/09/2011
 M.Bowden
 Global R & D Director - Walk behind
 Keeper of Technical Documentation

M. Bowden . 

Type	LRC3400
Width of Cut (cm)	34
Speed of Rotation of Cutting Device (rpm)	3,500
Power (kW)	0.75
Measured Sound Power L_{WA} (dB(A))	93
Guaranteed Sound Power L_{WA} (dB(A))	95
Level L_{pA} (dB(A))	78.4
Uncertainty K_{pA} (dB(A))	2.5
Value a_h (m/s ²)	1,87
Uncertainty K_{ah} (m/s ²)	1.5
Weight (Kg)	9.9

Husqvarna AB
 561 82
 Huskvarna
 Sweden

Our policy of continuous improvement means that the specification of products may be altered from time to time without prior notice.

Copyright © 2011 Flymo S.A. All rights reserved. Flymo® and other product and feature names are registered or unregistered trademarks of Flymo S.A.

