

HOLLOW TINE AERATOR



SPARES & SUPPORT: 01793 333212

Please read & understand this manual, paying particular attention to the safety instructions, before use.

The manufacturer reserves the right to change the product specification and livery according to continued product improvements.

CONTENTS

- SPECIFICATIONS**
- IMPORTANT INFORMATION**
- GENERAL SAFETY INSTRUCTIONS**
- COMPONENTS**
- ASSEMBLY**
- OPERATION**
- CLEANING**
- STORAGE & TRANSPORT**
- PARTS DIAGRAM & LIST**
- WARRANTY**

Assembly Is Required

This product requires assembly before use. See the “Assembly” section for instructions. Please check that all parts required for the assembly of this spreader are included. If for any reason you believe a part for the assembly is missing or damaged, please contact us.

If you require any assistance with regards to the contents or operation of your machine, please contact us:

TEL: 01793 333212
(MON – FRI 8.00AM TO 5.30PM EXCL. BANK HOLIDAYS)

EMAIL: customerservice@handydistribution.co.uk

SPECIFICATIONS

The manufacturer reserves the right to change the product specification and livery according to continued product improvements.

Model Number	THHTA
Product Number	193899001
Tine Diameter (mm)	16
Tine Length (mm)	50
Material	Steel
Overall Size (mm)	(L) 130 (W) 305 (H) 955
Weight (kg)	G.W 4.0 - N.W 3.0

IMPORTANT INFORMATION

INTENDED USE

The device is intended for producing holes with soil to allow oxygen to the roots and the soil to breathe. Also ideal for preparing for seed and top dressing.

This product is not intended for commercial use. Generally acknowledged accident prevention regulations and enclosed safety instructions must be observed.

Only perform work described in these instructions for use. Any other use is incorrect. The manufacturer will not assume responsibility for damage resulting from such use.

WORK AREA SAFETY

1. Keep work area clean and well lit. Cluttered or dark areas invite accidents.
2. Keep children and bystanders away while using the product. Distractions can cause you to lose control.

PERSONAL SAFETY



1. Stay alert, watch what you are doing and use common sense when using the product. Do not use this product while you are tired or under the influence of drugs, alcohol or medication. A moment of inattention while using the machine may result in serious personal injury.
2. Use safety equipment. Always wear eye protection. Safety equipment such as a dust mask, non-skid safety shoes, hard hat, and heavy duty work gloves used for appropriate conditions will reduce personal injuries.
3. Do not overreach. Keep proper footing and balance at all times. This enables better control of the product in unexpected situations.
4. Dress properly. Do not wear loose clothing or jewelry. Keep your hair, clothing and gloves away from moving parts. Loose clothes, jewelry or long hair can be caught in moving parts.

TOOL USE & CARE

1. Do not overload the product. Use the correct product for your application. The correct product will do the job better and safer at the rate for which it was designed.
2. Store idle tools out of the reach of children and do not allow people unfamiliar with the product or these instructions to operate the tool. Tools are dangerous in the hands of untrained users.
3. Maintain the product. Check for misalignment or binding of moving parts, breakage of parts and any other condition that may affect the tool's operation. If damaged, have the product repaired before use. Many accidents are caused by poorly maintained tools.
4. Use the product in accordance with these instructions and in the manner intended for this particular type of tool, taking into account the working conditions and the work to be performed. Use of the product for operations different from those intended could result in a hazardous situation.

GENERAL SAFETY INSTRUCTIONS

It is important that you read and understand the owner's manual and labels affixed to the machine. Learn its application and limitations as well as the specific potential hazards. Retain these instructions for future reference. The operator is responsible for following the warnings & instructions in this manual and on the product.

	<p>Read & understand operator's manual before using the machine. Failure to follow instructions could result in death or serious injury.</p>		<p>The maximum weight must not be exceeded. Failure to adhere to this information, could cause potential personal injury hazards.</p>
	<p>Use safety equipment. Always wear eye protection. Safety equipment such as a dust mask, non-skid safety shoes, hard hat, and heavy duty work gloves used for appropriate conditions will reduce personal injuries.</p>		



Safety alert symbol. Used to alert you to potential personal injury hazards. Obey all safety messages that follow this symbol to avoid possible injury.



DANGER

Indicates an imminently hazardous situation which, if not avoided, will result in serious injury.



WARNING

Indicates a potentially hazardous situation which, if not avoided, could result in serious injury



CAUTION

Indicates a potentially hazardous situation which, if not avoided, may result in minor or moderate injury.

CAUTION

Used without the safety alert symbol indicates a potentially hazardous situation which, if not avoided, may result in property damage.

THE MACHINE

SUPPLIED AS STANDARD

Instruction Manual, Aerator Frame, Spring Tines X5, Tool

ASSEMBLY

- Lift the Aerator from the carton.
- The Aerator will be complete, however for transit it will be folded in two.
- Unfold the top handle from the lower section of the Aerator
- Tighten the two wing nuts, located on the outside of the Aerator on both sides.
- Your Aerator is now ready to use.

OPERATION



DANGER

The product must only be put into operation if no defects are found. It is crucial that any defective parts are replaced before the product is used again.

Check the safety equipment and the safe condition of the product:

- Check whether the hopper is empty.
 - Check all parts to make sure that they fit tightly.
 - Check whether there are any visible defects: broken parts, cracks, etc.
-
- Depress aerator into the lawn with pressure on cross bar with your foot.
 - Cores will be pushed into core collection box when you next insert tines into the lawn.
 - Empty collection box into wheelbarrow or suitable receptacle.
 - Fill holes produced with suitable top dressing.

NB. It is recommended that you lightly water the ground in dry conditions to reduce the amount of pressure required.

NUMBER OF TINES REQUIRED

Five tines will push into most types of lawn. However, if you find the lawn is too hard, some tines can easily be removed to make lawn penetration easier. Using the supplied spanner, loosen the nut in the collection tray, by rotating anti-clockwise until the tine is removed. Store in a safe place, for future usage.

CLEANING

CLEANING THE DEVICE

- Careful handling and regular cleaning ensure that the device will remain functional & powerful for a long time.
- Brush off coarse dirt.
- Wipe down the device with a slightly damp cloth.
- Never spray the device with water or subject it to water.
- To clean, never use cleansers or solvents. This can cause irreparable damage to the device. The plastic parts can be eaten away by the chemicals.
- The spike on your supplied spanner can be used to clear soil from the tine inner.

STORAGE & TRANSPORT

STORAGE



WARNING

Make sure that unauthorised persons do not have access to the device!

- Store the product in a dry place.
- Store away from direct sunlight.
- Do not store anything above or near the machine, where anyone might stand on the machine to reach them.
- Keep the machine away from children and others not qualified to use it.

TRANSPORT

- Secure the device against slipping.
- When shipping, use the original packaging if possible.

PARTS DIAGRAM & LIST – THHTA (193899001)

NOTE: Parts Lists are supplied for information purposes only, not all parts are stocked individually & we recommend you contact our Spares Team on 01793 333212 for expert advice.

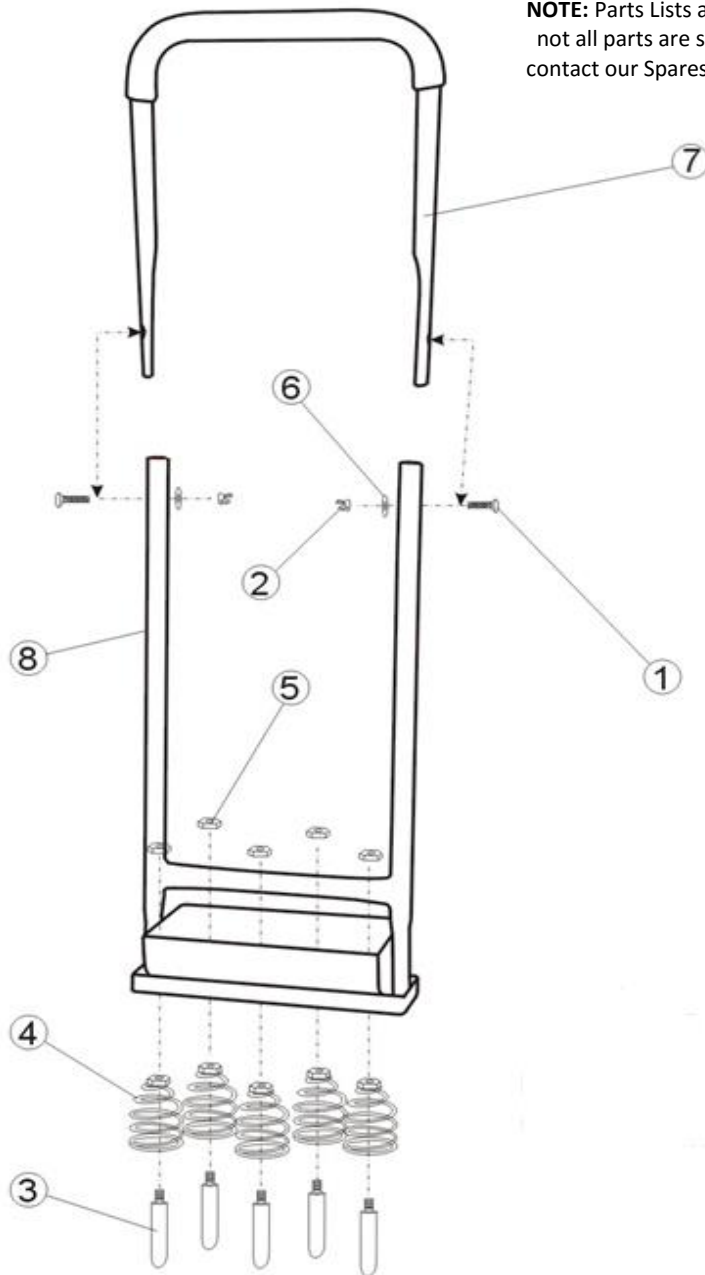

Item No.	Part No.	Description	Qty
1	THHTA-BOLT/WING NUT	45mm Carriage Bolt	2
2		Wing Nut	2
3	THHTATINE	Coring Tine	5
4	THHTASPRING	Tine Spring	5
5	THHTA-TINE NUT	Tine Nut	5
6	THHTA-WASHER	Washer	2
7	TH226-1	Upper Handle (Gun Metal)	1
8	TH226-2	Lower Body (Gun Metal)	1
9	THHTATOOL	Tine Tool	1

GJ HANDY & CO LTD USER WARRANTY POLICY

Users Statement of Warranty

Each new machine is warranted against defective material or assembly of material under normal usage. The warranty applies to the original purchaser and covers faulty parts and the labour involved in replacing and repairing those parts, which are of original manufacture.

Period of Warranty

All Webb, Handy Pro (Brushcutter & Long Handle Hedgecutter only) and Sanli domestic products.

2 years from the original date of sale to the first domestic user.

90 days from the original date of sale to the professional/commercial user.

90 days from the original date of sale when used for hire.

A reduced warranty period of 90 days applies to those items which are subject to normal wear and tear (e.g. wheels, tyres, cutter bars, cylinders, bottom blades, belts, cables, grass bags, spark plugs).

Engines as per the manufacturer's warranty statement which will be supplied with the machine.

90 days from the original date of purchase for Replacement Spare Parts (unless normal wear & tear component, which are covered for 30 days).

All machines' must be serviced within the first 12 months from the original date of purchase to comply with the warranty, failure to do so will invalidate the 2nd year of the warranty.

All Handy, Handy Pro (All others), Mowerland and Q-Garden domestic products.

1 year from the original date of sale to the first domestic user.

90 days from the original date of sale to the professional/commercial user.

90 days from the original date of sale when used for hire.

A reduced warranty period of 90 days applies to those items which are subject to normal wear and tear (e.g. wheels, tyres, cutter bars, cylinders, bottom blades, belts, cables, collection bags, spark plugs).

Engines as per the manufacturer's warranty statement which will be supplied with the machine.

90 days from the original date of purchase for Replacement Spare Parts (unless normal wear & tear component, which are covered for 30 days).

All warranty repairs must be undertaken by an authorised service dealer. These dealers have been accredited by GJ Handy & Co Ltd and agree to only use genuine parts and follow our repair procedures.

GJ HANDY & CO LTD USER WARRANTY POLICY

Not covered by this warranty

- a) The warranty policy does not cover any depreciation or damages caused by ordinary wear, rusting or corrosion, lack of correct maintenance or operation, misuse, abuse, lack of transportation or accident.
- b) The warranty policy does not cover any costs necessary for the standard periodic maintenance services instructed by the operators manual, or service parts replacement which would include oil, filters, tyres, belts, brake linings, fuses, blades, seals and other service parts unless it can be proven that the item has evidence of faulty manufacture.
- c) The warranty policy will not cover failure or damage caused as a result of parts or accessories being modified without the written approval of GJ Handy & Co Ltd.
- d) The warranty policy will not cover the unit if non-genuine parts have been fitted and as a result damage has occurred to the unit.
- e) The warranty policy is non-transferable and is only applicable to the original purchaser.

Disclaimer

- a) This warranty is only a remedy for defect of products. GJ Handy & Co Ltd will never warranty in terms of the merchantability or the fitness for a particular purpose.
- b) No person is authorised to make any warranties, representations or promises, expressed or implied, on behalf of GJ Handy & Co Ltd, or to modify the terms conditions or limitation of this warranty policy in any way.
- c) Neither GJ Handy & Co Ltd nor any company affiliated with GJ Handy & Co Ltd shall be liable in any event or manner whatsoever for incidental or consequential damages or injuries, including, but not limited to, loss of crops, loss of profit, out of pocket expenses or profits, rental of substitute equipment or other commercial losses.

General

- a) Most warrantable failures show up within the first few weeks of use. These failures are usually straightforward and warranty assessment is relatively easy.
- b) Failures relating to cutter decks and belts need careful investigation, as the cause may not always be straightforward. Look for damage to blades and pulleys especially when the cutter belt or blade boss have snapped or cracked as this could be due to impact damage.
- c) Customers should always refer to the operator/instruction manual when any disputed problem arises, you will find most areas covered within the manual.

**FOR SPARES OR SUPPORT OF YOUR HANDY PRODUCT,
PLEASE CONTACT US:**

**TEL: 01793 333212
(MON – FRI 8.00AM TO 5.30PM EXCL. BANK HOLIDAYS)**

EMAIL: customerservice@handydistribution.co.uk

To see our complete range of garden machinery and equipment visit:

www.thehandy.co.uk

Distributed by Handy Distribution, Murdock Road, Dorcan, Swindon, SN3 5HY