

Puzzi 10/1
Puzzi 10/2 Adv

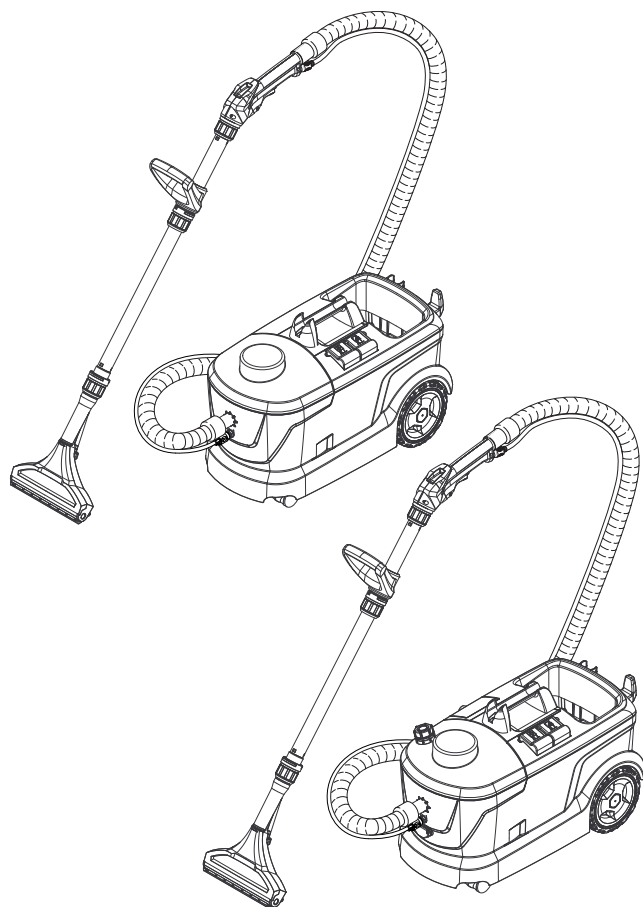

Deutsch	4
English	12
Français	19
Italiano	27
Nederlands	35
Español	43
Português	51
Dansk	59
Norsk	66
Svenska	73
Suomi	80
Ελληνικά	87
Türkçe	95
Русский	102
Magyar	111
Čeština	119
Slovenščina	126
Polski	133
Românește	141
Slovenčina	149
Hrvatski	157
Srpski	164
Български	172
Eesti	180
Latviešu	187
Lietuviškai	194
Українська	201

Register and win!
www.kaercher.com/register-and-win



A

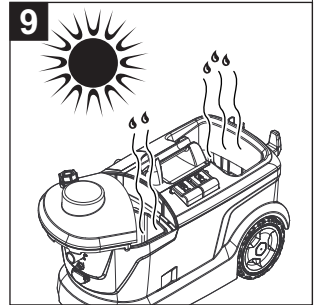
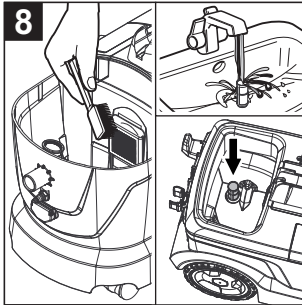
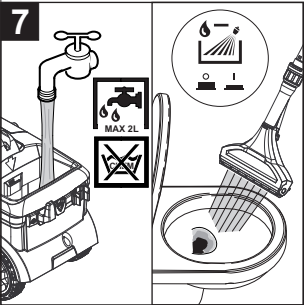
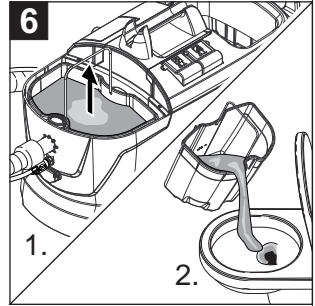
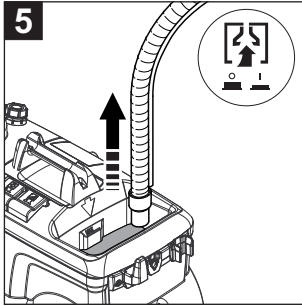
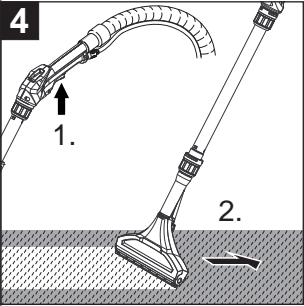
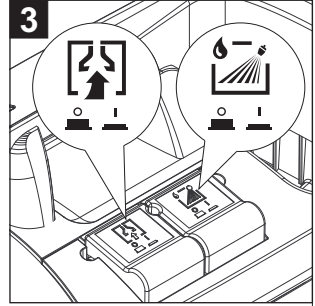
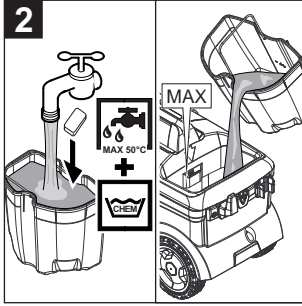
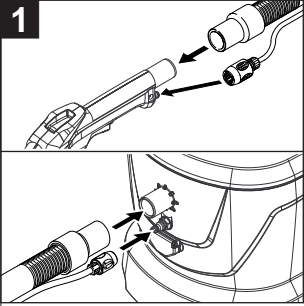

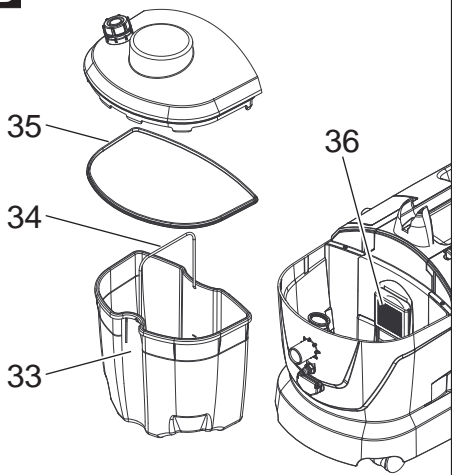
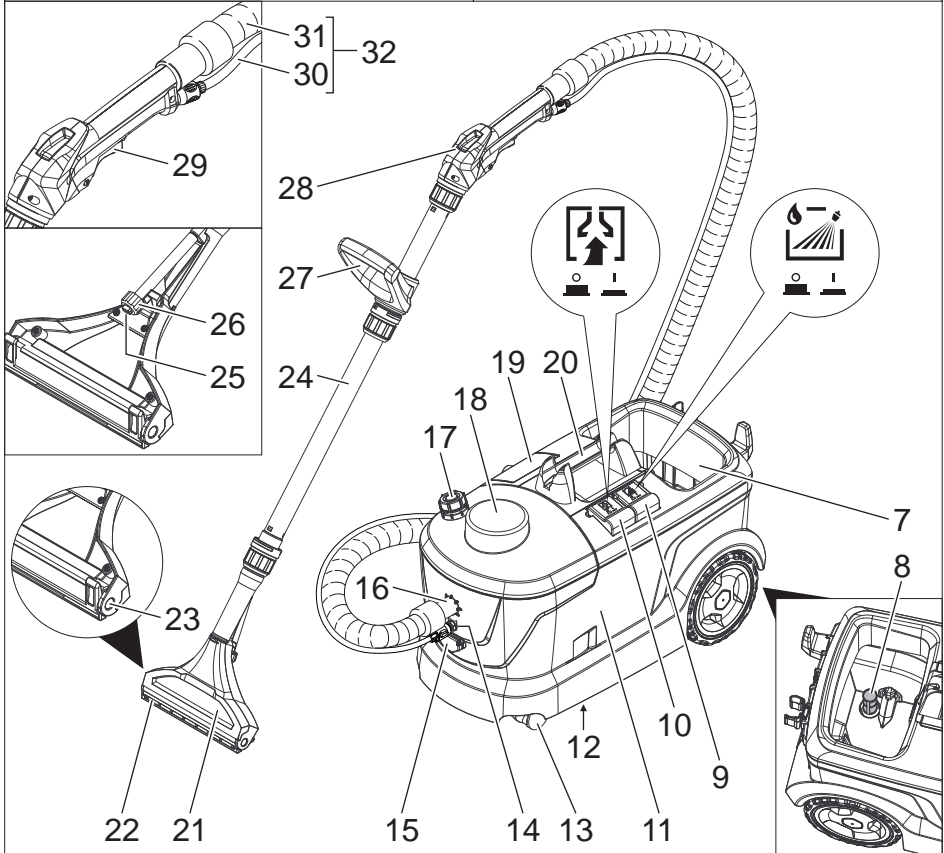
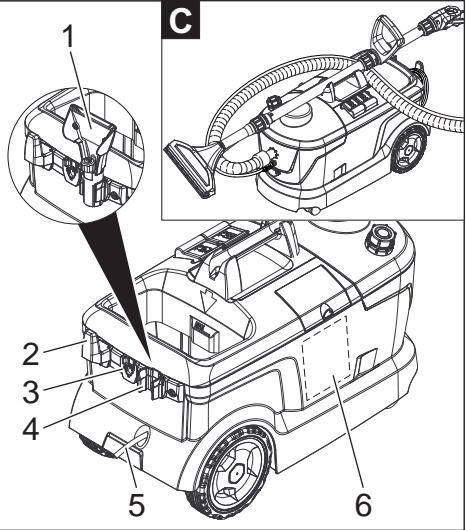
B**C**



Please read and comply with these original instructions prior to the initial operation of your appliance and store them for later use or subsequent owners.

- Before initial start-up it is definitely necessary to read the safety information no. 5.956-251.0!
- The non-compliance of the operating and safety instructions may lead to damages of the appliance and to dangers for the operator and other persons.
- In case of transport damage inform vendor immediately

Contents

Environmental protection	EN . . . 1
Symbols in the operating instructions	EN . . . 1
Proper use	EN . . . 1
Overview	EN . . . 2
Start up	EN . . . 2
Operation	EN . . . 3
Cleaning methods	EN . . . 4
Transport	EN . . . 5
Storage	EN . . . 5
Maintenance and care	EN . . . 5
Troubleshooting	EN . . . 5
Accessories and Spare Parts . .	EN . . . 6
Warranty	EN . . . 6
EC Declaration of Conformity . .	EN . . . 6
Technical specifications	EN . . . 7

Environmental protection



The packaging material can be recycled. Please do not throw the packaging material into household waste; please send it for recycling.



Old appliances contain valuable materials that can be recycled; these should be sent for recycling. Batteries, oil, and similar substances must not enter the environment. Please dispose of your old appliances using appropriate collection systems.

Notes about the ingredients (REACH)

You will find current information about the ingredients at:

www.kaercher.com/REACH

Symbols in the operating instructions

Danger

Immediate danger that can cause severe injury or even death.

Warning

Possible hazardous situation that could lead to severe injury or even death.

Caution

Possible hazardous situation that could lead to mild injury to persons or damage to property.

Proper use

This device is intended for commercial use as a wet cleaning device for carpets as depicted in these operating instructions as well as in the descriptions and safety notes in the enclosed brochure "Safety indications for brush cleaning devices and spray extraction devices".

Overview

Quick start instructions

Illustration **A**

- 1 Connect spray/suction hose to the elbow,
Connect spray/suction hose to the appliance
- 2 Prepare cleaning solution,
Fill up the fresh water tank
- 3 Select operating mode
- 4 Cleaning
- 5 Empty the fresh water tank
- 6 Empty wastewater container
- 7 Fill fresh water tank (without detergent),
Flush appliance
- 8 Clean lint trap,
Clean fresh water sieve
- 9 Allow appliance to dry

Device elements

Illustration **B**

- 1 Hand nozzle for upholstery cleaning
(Puzzi 10/1 only)
- 2 Cable hook
- 3 Adapter for accessories (homebase)
- 4 Holder for accessories
- 5 Power cord
- 6 Quick start instructions
- 7 Fresh water tank
- 8 Fresh water sieve
- 9 Switch for spraying
- 10 Switch for vacuuming
- 11 Casing
- 12 Nameplate
- 13 Steering roller
- 14 Spray hose connection
- 15 Socket for additional brush washing
head PW 30/1 (Puzzi 10/2 Adv only)
- 16 Suction hose connection
- 17 Container for defoaming agent (Puzzi
10/2 Adv only)
- 18 Cover
- 19 Storage compartment for detergent
tabs (Puzzi 10/2 Adv only)
- 20 Carrying handle of the appliance
- 21 Floor nozzle for carpet cleaning
- 22 Carpet adapter

- 23 Unlocking device of the floor nozzle
- 24 Suction pipe
- 25 Nozzle mouth piece
- 26 Union joint
- 27 Handle
- 28 Bender
- 29 Lever on the manifold
- 30 Spray hose
- 31 Suction hose
- 32 Spray/suction hose
- 33 Dirt water reservoir, detachable
- 34 Carrying handle of the wastewater container
- 35 Seal on the lid
- 36 Fluff filter

Start up

- Check high power cable, extension cables and hoses for damage every time before use.

Attaching the Accessories

- Attach the suction pipe to the floor nozzle and hand-tighten the union nut on the floor nozzle.
- If required, slide the handle onto the suction pipe and hand-tighten it in the desired position.
- Place the elbow over the suction pipe and tighten the union joint on the elbow fingertight.
- Insert the suction hose into the suction hose connection on the appliance. Attach the coupling of the spray hose to the spray hose connection of the appliance and snap in place.
- Connect the suction hose to the elbow. Connect the coupling of the spray hose with the manifold and snap in place.

Prepare cleaning solution

⚠ Warning

Health risk, risk of damage. Observe all indications on the detergent used.

- Mix fresh water and detergent in a clean container (use the concentration recommended for the detergent). Dissolve detergent in the water.

Note: Warm water (max. 50°C) will increase the cleaning effect. Verify the temperature resistance of the surface to be cleaned.

Note: For considerate treatment of the environment use detergent economically.

Fill up fresh water reservoir

- Fill detergent solution into the fresh water reservoir. The fill level must not exceed the "MAX" mark.

Defoaming agent

Note: When cleaning previously shampooed carpets, foam is generated in the wastewater container. This formation of foam can be prevented by adding a defoaming agent.

Puzzi 10/1 only:

- Put defoaming agent (optional accessory) into the wastewater container.

Puzzi 10/2 Adv only:

- Open container for defoaming agent.
- Fill in defoaming agent (optional accessory).

Replacing the carpet adapter

- Push the unlocking device of the floor nozzle on one side.
- Swivel out and remove the carpet adapter.
- Insert a new carpet adapter and snap the locking device in place.

Operation

Working with attachments

Puzzi 10/2 Adv only:

Note: There is an additional socket to connect electrical accessory devices.

Danger

Risk of injury and damage! The socket is only intended for the direct connection of the additional brush washing head PW 30/1 to the Puzzi 10/2 Adv. Any other use of the socket is not permitted.

Turning on the Appliance

- Plug in the main plug.
- Press the suction switch to turn on the suction turbine.
- Press the spray switch to switch on the spray pump.

Cleaning

Caution

Risk of damage. Check the object to be cleaned prior to using the appliance in an inconspicuous place for colour fastness and water resistance.

- Operate the lever on the manifold in order to spray the cleaning solution.
- Run across the surface to be cleaned in overlapping paths. Pull the nozzle backwards (do not push).
- In case of work interruptions, the floor nozzle can be stored in the handle.

Turn off the appliance

- Switch off the spray and suction switches.
- Pull out the mains plug.

Empty wastewater container

- If the dirt water reservoir is full, switch off the suction and spray switches.
- Remove the lid.
- Remove the wastewater container from the appliance and drain it.

Empty the fresh water reservoir

- Turn off the appliance.
- Shortly activate the lever on bender to decrease the pressure.
- Separate bender from the spray/suction hose.
- Insert the suction hose into the fresh water reservoir.
- Press the suction switch to turn on the suction turbine.
- Empty the fresh water reservoir and switch the appliance off.
- Remove the lid.
- Remove the wastewater container from the appliance and drain it.

Flush appliance

- Connect the manifold (with suction pipe and nozzle) to the suction hose.
 - Connect the coupling of the spray hose with the manifold and snap in place.
 - Fill approx. 2 litres of fresh water into the fresh water reservoir.
- Do not add any detergents.**
- Press the spray switch to switch on the spray pump.
 - Hold floor nozzle over a drain.
 - Activate lever on bender and flush the appliance for appr. 1 to 2 minutes.
 - Turn off the appliance.

After each operation

- Flush appliance.
- Empty the wastewater container and clean it under running water.
- Empty the fresh water reservoir.
- Clean the outside of the appliance with a damp cloth.
- Remove all water from the appliance prior to longer periods of non-use to avoid offensive odours.
- Allow appliance to dry thoroughly: Remove or move lid sideways.

Storing the Appliance

- Place the appliance in a dry room and secure it from unauthorized use.

Cleaning methods

Normal soiling

- Spray and suction off detergent solution in one work cycle.

Note: Repeated suctioning without spraying will shorten the drying time.

Strong soiling or stains

- Apply detergent solution with suction turbine turned off and soak for 10 to 15 minutes.
- Clean the surface just like with normal soiling.
- In order to further improve the cleaning result, the surface can be recleaned using clear, warm water.

Upholstery cleaning

- Puzzi 10/1 only:
Attach hand nozzle instead of the floor nozzle.
- With sensitive materials, use less detergent and spray the surface at a distance of approx. 200 mm. Then simply vacuum off.

Cleaning tips

- Highly soiled spots should be pre-soaked and the detergent solution should soak 5 to 10 minutes.
- Always work from the light to the shade (from the window to the door).
- Always work from the cleaned to the uncleaned surface.
- The more sensitive the surface (oriental rugs, berbers, upholstery material) the lower the cleaning solution concentration should be.
- Rugs with jute backing can shrink if too much water is used and can bleed colours.
- Brush high-fiber rugs in the direction of the weave after cleaning (using a fiber brush or a scrubber).
- Water-proofing the fabric using Care Tex RM 762 after the wet cleaning prevents a quick resoiling of the textile surface.
- Do not step on cleaned surfaces until they have dried and do not place furniture on them to avoid pressure spots or rust stains.

Detergent

Carpet and upholstery cleaning	RM 760 powder
	RM 760 tabs
	RM 764 liquid
Defoaming	RM 761
Waterproofing carpets	RM 762

For further information, please request product information sheet and EU safety data sheet of the relevant detergent.

Transport

Caution

Risk of injury and damage! Observe the weight of the appliance when you transport it.

Illustration 

- For transport, place suction pipe on the carrying handle and place the spray/suction hose on top of the appliance. Wind up the mains cable and hook it into the cable hook.
- When transporting in vehicles, secure the appliance according to the guidelines from slipping and tipping over.

Storage

Caution

Risk of injury and damage! Note the weight of the appliance in case of storage.

This appliance must only be stored in interior rooms.

Maintenance and care

Danger

Danger of injury by electric shock. First pull out the plug from the mains before carrying out any tasks on the machine.

Clean the fluff filter

- Remove the lid.
- Remove the wastewater container from the appliance.
- Regularly clean the lint trap using a brush.

Cleaning the fresh water sieve

- Unscrew the fresh water sieve.
- Regularly clean the fresh water sieve under running water.

Cleaning the nozzle

- Unscrew the covering nut.
- Clean nozzle mouthpiece.

Troubleshooting

Danger

- *Danger of injury by electric shock. First pull out the plug from the mains before carrying out any tasks on the machine.*
- *Get the electrical components checked and repaired only by authorised customer service persons.*

Appliance is not working

- Check the receptacle and the fuse of the power supply.
- Check the power cable and the power plug of the device.
- Turn on the appliance.

No water exiting from nozzle

- Fill up fresh water reservoir.
- Check the couplings on the spray hose for proper seating.
- Clean or replace nozzle tip.
- Clean the sieve in the fresh water reservoir.
- Spray pump defective, contact after-sales service.

Spray stream one-sided

- Clean nozzle mouthpiece.

Insufficient vacuum performance

- Check the correct positioning of the lid.
- Clean seal on lid and surface on the appliance.
- Clean the fluff filter.
- Check suction hose for blockages; clean if required.

Spray pump loud

→ Fill up fresh water reservoir.

Heavy formation of foam in the wastewater container

→ Add the defoaming agent into the wastewater container or fill up the container for the defoaming agent.

Customer Service

If malfunction can not be fixed, the device must be checked by customer service.

Accessories and Spare Parts

- Only use accessories and spare parts which have been approved by the manufacturer. The exclusive use of original accessories and original spare parts ensures that the appliance can be operated safely and trouble free.
- At the end of the operating instructions you will find a selected list of spare parts that are often required.
- For additional information about spare parts, please go to the Service section at www.kaercher.com.

Warranty

The warranty terms published by the relevant sales company are applicable in each country. We will repair potential failures of your appliance within the warranty period free of charge, provided that such failure is caused by faulty material or defects in manufacturing. In the event of a warranty claim please contact your dealer or the nearest authorized Customer Service centre. Please submit the proof of purchase.

EC Declaration of Conformity

We hereby declare that the machine described below complies with the relevant basic safety and health requirements of the EU Directives, both in its basic design and construction as well as in the version put into circulation by us. This declaration shall cease to be valid if the machine is modified without our prior approval.

Product: Spray extraction device

Type: 1.100-xxx

Type: 1.193-xxx

Relevant EU Directives

2006/42/EC (+2009/127/EC)

2004/108/EC

2011/65/EU

Applied harmonized standards

EN 55014-1: 2006+A1: 2009+A2: 2011

EN 55014-2: 1997+A1: 2001+A2: 2008

EN 60335-1

EN 60335-2-68

EN 61000-3-2: 2006+A1: 2009+A2: 2009

EN 61000-3-3: 2008

EN 62233: 2008

EN 50581

Applied national standards

-

5.957-534

The undersigned act on behalf and under the power of attorney of the company management.

H. Jenner
CEO



S. Reiser
Head of Approval

Authorized Documentation Representative
S. Reiser

Alfred Kärcher GmbH Co. KG
Alfred-Kärcher-Str. 28 - 40
71364 Winnenden (Germany)
Phone: +49 7195 14-0
Fax: +49 7195 14-2212

Winnenden, 2013/12/01

Technical specifications

		Puzzi 10/1	Puzzi 10/2 Adv
Mains voltage	V	EU: 220-240	EU: 220-240
	V	GB: 230-240	GB: 230-240
	V	AU: 240	AU: 240
	V	AR: 220	AR: 220
Frequency	Hz	1~ 50/60	1~ 50/60
Type of protection	--	IPX4	IPX4
Protective class		II	II
Nominal performance of blower motor	W	1100	1100
Power (tot.)	W	--	1350
Air volume (max.)	l/s	54	54
Negative pressure (max.)	kPa (mbar)	22 (220)	22 (220)
Spray pump performance	W	40	80
Spray pressure	MPa	0,1	0,2
Spray pressure (max.)	MPa	0,3	0,3
Spray volume	l/min	1	2
Temperature of the cleaning solution (max.)	°C	50	50
Filling quantity of fresh water	l	10	10
Fill volume wastewater	l	9	9
Appliance socket performance (max)	W	--	250
Length x width x height	mm	705 x 320 x 435	705 x 320 x 435
Typical operating weight	kg	10,7	11,4
Max. ambient temperature	°C	+40	+40

Values determined to EN 60335-2-68

Sound pressure level L_{pA}	dB(A)	EU: 74	EU: 74
	dB(A)	GB: 76	GB: 76
Uncertainty K_{pA}	dB(A)	1	1
Hand-arm vibration value	m/s^2	<2,5	<2,5
Uncertainty K	m/s^2	0,2	0,2

Power cord	H05VV-F 2x1,0 mm ²	
	Part no.:	Cable length
EU	6.650-363.0	7.5 m
GB	6.650-380.0	7.5 m
AU	6.650-385.0	7.5 m
AR	6.650-382.0	7.5 m