



INSTRUCTIONS FOR
365KG HYDRAULIC MOTORCYCLE LIFT
 MODEL NO: **MC365.V2**

Thank you for purchasing a Sealey product. Manufactured to a high standard, this product will, if used according to these instructions, and properly maintained, give you years of trouble free performance.

IMPORTANT: PLEASE READ THESE INSTRUCTIONS CAREFULLY. NOTE THE SAFE OPERATIONAL REQUIREMENTS, WARNINGS & CAUTIONS. USE THE PRODUCT CORRECTLY AND WITH CARE FOR THE PURPOSE FOR WHICH IT IS INTENDED. FAILURE TO DO SO MAY CAUSE DAMAGE AND/OR PERSONAL INJURY AND WILL INVALIDATE THE WARRANTY. KEEP THESE INSTRUCTIONS SAFE FOR FUTURE USE.



Refer to
 Instruction
 Manual



No reaching in

1. SAFETY

- WARNING!** THIS LIFT IS ONLY SUITABLE FOR MOTORCYCLES WHICH HAVE A CENTRE STAND.
- WARNING!** Ensure the bike is adequately strapped onto the platform before operating.
- Maintain the lift in good condition (use an authorised service agent).
- Replace or repair damaged parts. Use genuine parts only. Unauthorised parts may be dangerous and will invalidate the warranty.
- Use a qualified person to lubricate and maintain the lift. **DO NOT** use brake fluid to top up hydraulic unit.
- Locate the lift in a suitable work area, keep area clean and tidy and free from unrelated materials, and ensure that there is adequate lighting. Also ensure that the floor is level and strong enough (preferably concrete) to take the weight of the lift and the bike. **DO NOT** operate the lift on tarmac, as the surface may be unstable.
- Keep the lift clean for best and safest performance.
- The maximum bike weight is 365kg. **DO NOT** exceed this rated capacity.
- Remove ill fitting clothing. Remove ties, watches, rings and other loose jewellery, and contain long hair.
- Maintain correct balance and footing, do not over reach. Ensure the floor is not slippery and wear non-slip shoes.
- Ensure the bike is adequately secured to the lifting platform with appropriate straps.
- Before lifting check that there are no overhead obstructions.
- When platform has been raised to the working height ensure the locking bar is engaged to prevent accidental lowering.
- Keep children and unauthorised persons away from the work area.
- The lowering speed will vary according to the weight of the load and the amount by which the release pedal is depressed.
- DO NOT** use the lift for a task it is not designed to perform.
- DO NOT** operate the lift if damaged.
- DO NOT** exceed the rated capacity of the lift.
- DO NOT** operate the lift when you are tired or under the influence of alcohol, drugs or intoxicating medication.
- DO NOT** allow untrained persons to operate the lift.
- DO NOT** attempt to transport a load on the lift. The lift must only be used in a static position for raising and lowering loads.
- DO NOT** make any modifications to the lift and **DO NOT** adjust or tamper with the safety valve.
- Before lowering the lift ensure that there are no obstructions underneath and that all persons are standing clear.
- Before storing in safe area, ensure all parts are clean and free of grease and oil. Store lift in the lowest position.

2. INTRODUCTION

All steel construction with foot operated, integral hydraulic pump and ram assembly. Fitted with safety lock device to fix platform at three Working heights of 760mm, 640mm and 500mm and to prevent accidental lowering. Suitable only for motorcycles with a centre stand. Support platform fitted with full width loading ramp. Base assembly fitted with transport wheels and lock downs to prevent lift from moving during use.

3. SPECIFICATION

Model no: **MC365.V2**
 Capacity: 365kg
 Minimum height: 220mm
 Maximum height: 760mm
 Width: 480mm
 Length: 2215mm
 Max. load length: 1350mm

4. CONTENTS

Unpack the lift and check contents with list below. Should there be any damaged or missing parts contact your supplier immediately.

- Main Assembly
- Sliding Plate
- Leading Plate
- Vice
- Lifting Pedal
- Release Pedal
- Bolts, Washers, Nuts, Cotter Pins

5. ASSEMBLY

- ❑ **WARNING!** Keep your hands away from moving parts.
Numbers in brackets refer to item numbers in the parts diagram.
- 5.1. Attach lead plate (31) to end of platform (32) using bolts (30).
- 5.2. Fit the front wheel vice assembly (35, 47) to the front of the platform (32) using bolts (33), washers (34) and nuts (38).
- 5.3. Insert the lift foot pedal (7) into the pump piston spindle and insert the release foot pedal (10) into the release valve spindle (18).
- 5.4. Attach baffle plate (39) using bolts (33), washers (34) and nuts (38).
- 5.5. **BEFORE FIRST USE**
 - 5.5.1. Leave the pump for one hour, to allow the oil to settle, before purging the system.
Note: Failure to allow sufficient time for the oil to settle could result in air remaining in the oil. In this event, the pump will not purge completely first time and a second purge will be required.
 - 5.5.2. Purge the hydraulic circuit to eliminate any air in the system, by fully pressing the release valve pedal (10) and pumping the lift pedal (7) 15 to 20 times.
 - 5.5.3. Test the lift, unladen, by raising it to full height and then lowering it. Depress release valve pedal (10) slowly to control the rate of descent.

6. OPERATION

- ❑ **WARNING!** Ensure that you read, understand and apply the safety instructions before use.
- ❑ **WARNING! DO NOT** attempt to overload the lift. The hydraulic pump is equipped with safety valve which will prevent an excessive load from being lifted.
- 6.1. Position the lift in a suitable area, checking that the surface on which the lift will stand is solid and flat (preferably concrete).
- 6.2. Check that the lift is fully lowered and that the vice jaws are open.
- 6.3. Wheel the bike up the lead plate (31) and onto the platform so that the front of the wheel is just beyond the vice. Support bike on the centre stand.
Note: There is a choice of mounting holes for the vice to cater for various sizes of bike.
- 6.4. Clamp front wheel in vice to prevent any movement of the bike.
- 6.5. Ensure the bike is securely strapped to the platform.
- 6.6. Raise the lift by pumping the lift foot pedal (7).
- 6.7. When the lift is fully raised pass the locking bar (48) through the holes in the underside of the main platform (32) so that the lift cannot be inadvertently lowered.
- 6.8. When work is complete, check under the lift to ensure that there are no obstructions and that it is safe to lower the unit.
- 6.9. Remove the locking bar and then **SLOWLY** press the release valve pedal (10) to **GENTLY** lower the lift.
 - ▲ **IMPORTANT!** The speed of lowering is controlled by the release valve. The more the valve is opened the more rapidly the lift descends. Ensure the descent is slow and controlled.
- 6.10. When the lift is fully lowered, unstrap the bike, open the vice jaws and remove the bike from the lift.

7. MAINTENANCE

- 7.1. When the lift is not in use, it must be stowed in the lowest position to minimise ram and piston corrosion.
- 7.2. Keep the lift clean and wipe off any oil or grease. Lubricate all moving parts..
- 7.3. Before each use check all parts. If any part of the lift is damaged or suspect remove lift from service and take necessary action to repair.
DO NOT use the lift if it is believed to have been subjected to abnormal load or shock. Inspect and take appropriate action.
- 7.4. Periodically check the ram and piston for signs of corrosion. Clean exposed areas with a clean oiled cloth.
- 7.5. The hydraulic oil level is checked as follows:
 - 1) Remove hydraulic unit from lift and stand upright.
 - 2) Remove plug (fig.1). Correct oil level is up to plug aperture - add hydraulic oil as necessary.
- ❑ **WARNING!** Only a good quality hydraulic oil, such as SEALEY HYDRAULIC OIL, must be used. **DO NOT** use brake fluid.
- ▲ **IMPORTANT!** Only fully qualified personnel should attempt maintenance or repair. Contact your authorised dealer.

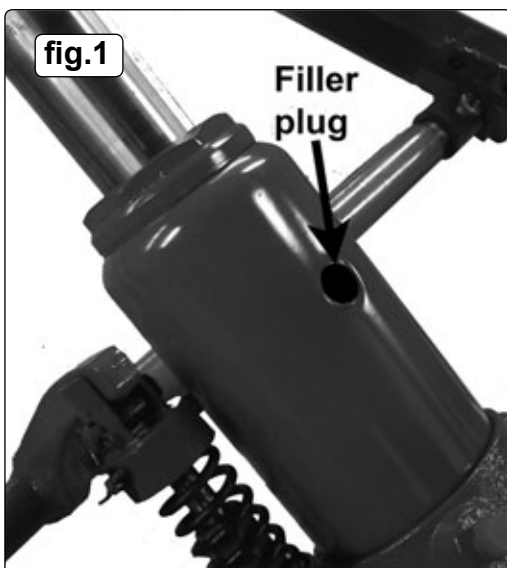



Environmental Protection



Recycle unwanted materials instead of disposing of them as waste. All tools, accessories and packaging should be sorted, taken to a recycling centre and disposed of in a manner which is compatible with the environment. When the product becomes completely unserviceable and requires disposal, drain off any fluids (if applicable) into approved containers and dispose of the product and the fluids according to local regulations.

NOTE: It is our policy to continually improve products and as such we reserve the right to alter data, specifications and component parts without prior notice.

IMPORTANT: No liability is accepted for incorrect use of this product.

WARRANTY: Guarantee is 12 months from purchase date, proof of which will be required for any claim.



Sole UK Distributor, Sealey Group.
Kempson Way, Suffolk Business Park,
Bury St. Edmunds, Suffolk.
IP32 7AR



01284 757500



01284 703534



www.sealey.co.uk



sales@sealey.co.uk