



INSTRUCTIONS FOR

ROADSTART EMERGENCY POWER PACKS

MODEL NOS: RS131.V3, RS132

Thank you for purchasing a Sealey product. Manufactured to a high standard, this product will, if used according to these instructions, and properly maintained, give you years of trouble free performance.

IMPORTANT: PLEASE READ THESE INSTRUCTIONS CAREFULLY. NOTE THE SAFE OPERATIONAL REQUIREMENTS, WARNINGS & CAUTIONS. USE THE PRODUCT CORRECTLY AND WITH CARE FOR THE PURPOSE FOR WHICH IT IS INTENDED. FAILURE TO DO SO MAY CAUSE DAMAGE AND/OR PERSONAL INJURY AND WILL INVALIDATE THE WARRANTY. KEEP THESE INSTRUCTIONS SAFE FOR FUTURE USE.



Refer to
Instruction
Manual



Warning:
Explosive
Material



Wear eye
Protection



Warning:
Corrosive
substance

1. SAFETY

IMPORTANT WARRANTY INFORMATION: KEEP YOUR ROADSTART HEALTHY

Read and understand the general safety and operating instructions before use. The following information is intended to help you keep the product in top working order.

NOTE – The battery in this unit is a consumable item and its ability to accept charge will reduce over time. We will warranty it against mechanical and electrical defect for a period of one year - this does not cover fair wear and tear.

If the battery is not properly charged before first use, or regularly conditioned, its capacity will diminish. Under these circumstances we will not replace the battery even if it is less than one year old.

You can help prolong the lifecycle of the battery by following a few simple guidelines.

- Plug in your new Roadstart to the mains transformer and make an INITIAL charge lasting 38 hours.
- Ensure the unit is fully charged before storage.
- **DO NOT** leave the Roadstart for longer than 2 months without putting it on charge.
- **DO NOT** attempt to start a vehicle when the Roadstart battery voltage is reduced to less than 7Volts.
- **DO NOT** drop or roughly handle the Roadstart – this will break or disjoin the battery terminals rendering the battery useless and the warranty void.
- **DO NOT** use any other charger, other than the one supplied, to recharge the battery.

IMPORTANT: To reduce the risk of a battery explosion, follow these instructions and those published by the battery manufacturer and the manufacturer of any equipment you intend to use in the vicinity of the battery. Remember to review warning marks on all products and on engines.

1.1. PERSONAL PRECAUTIONS

- ✓ Ensure there is another person within hearing range, or close enough to come to your aid should a problem arise, when working near a lead-acid battery.
- ✓ Have fresh water and soap nearby in case battery acid contacts skin, clothing or eyes.
- ✓ Wear safety eye protection and protective clothing. Avoid touching eyes while working with a battery.
- ✓ Wash immediately with soap and water if battery acid contacts skin or clothing. If acid enters eye, flush eye immediately with cool, clean running water for at least 15 minutes and seek immediate medical attention.
- ✓ Remove personal metallic items such as rings, bracelets, necklaces and watches. A lead-acid battery can produce a short-circuit current high enough to weld a ring or the like to metal, which may cause severe burns.

1.2. IMPORTANT SAFETY INSTRUCTIONS

- ✓ Familiarise yourself with the applications, limitations and potential hazards of the RoadStart.
- ✓ Keep the unit in good working order and condition. Replace damaged parts immediately.
- ✓ Use only recommended parts. To use unapproved parts may be dangerous and will invalidate your warranty.
- ✓ The RoadStart must only be opened and checked by qualified service personnel. **DO NOT** disassemble the unit for any reason.
- ✓ Keep children and unauthorised persons away from the work area.
- ✓ Keep work area clean and tidy and free from unrelated materials. Ensure that there is adequate lighting.
- ✓ If the RoadStart receives a sharp knock or blow, it must be checked by a qualified service agent before being used.
- ✓ When not in use re-charge every two months.
- ✗ **DO NOT** smoke or allow a spark, or flame in the vicinity of the battery or engine.
- ✗ **DO NOT** drop any metal item onto the battery as it may spark or short circuit the battery, which could cause an explosion.
- ✗ **DO NOT** use RoadStart to recharge dry cell batteries that are commonly used with home appliances. These batteries may explode and cause personal injury and damage to property.
- ✗ **DO NOT** charge or boost a frozen battery.
- ✗ **DO NOT** use attachments other than those recommended. To do so may risk damage to the unit and other equipment and possible personal injury.
- ✗ **DO NOT** pull or carry the unit by its cables and do not pull the negative and positive clamps from the battery terminals.
- ✗ **DO NOT** operate in vicinity of flammable liquids or gases.
- ✗ **DO NOT** recharge the unit with plugs, cables or attachments that are damaged. Replace such items immediately.
- ✗ **DO NOT** use this product to perform a task for which it is not designed.
- ✗ **DO NOT** store the unit in damp or wet locations or where the temperature may exceed 50°C.
- ✗ **DO NOT** submerge the unit in water.

- X **DO NOT** use whilst under the influence of drugs, alcohol or intoxicating medication.
- X **DO NOT** leave the unit in a totally discharged state for an extended period of time as this may result in permanent damage.
- X **DO NOT** cross-connect the power leads from the RoadStart to the battery. Ensure that positive is to positive and negative is to negative. Observe polarity indicator during connection.
- X Ensure that the unit is fully charged before storage.

1.3. ELECTRICAL SAFETY (with respect to mains chargers) 

- **WARNING!** It is the user's responsibility to check the following:

You must check the AC adaptor to ensure that it is safe before using. You must inspect the power supply lead, plugs and all electrical connections for wear and damage. You must ensure the risk of electric shock is minimised by the installation of appropriate safety devices. An RCCB (Residual Current Circuit Breaker) should be incorporated in the main distribution board. We recommend that an RCD (Residual Current Device) is used with all electrical products. It is particularly important to use an RCD with portable products that plug into an electrical supply not protected by an RCCB. If in doubt consult a qualified electrician. You can obtain a Residual Current Device through your Sealey dealer. You must read and understand instructions concerning electrical safety.

- 1.3.1. The **Electricity At Work Act 1989** requires all portable electrical appliances, if used on business premises, to be tested by a qualified person, using a Portable Appliance Tester (PAT), at least once a year.
- 1.3.2. The Health & Safety at Work Act 1974 makes owners of electrical appliances responsible for the safe condition of the appliance and the safety of the appliance operator. If in any doubt about electrical safety, contact a qualified electrician.
- 1.3.3. **DO** ensure that the insulation on all cables and the product itself is safe before connecting to the mains power supply.
- 1.3.4. **DO** ensure that cables are always protected against short circuit and overload.
- 1.3.5. **DO** regularly inspect power supply, leads, plugs for wear and damage and power connections to ensure that none is loose.
- 1.3.6. **DO** check product voltage is the same as power supply to be used and check that all fused plugs are fitted with the correct capacity fuses.

2. INTRODUCTION

Composite case with moulded rubber protection, integral battery cable storage and carry handle. LED battery condition, polarity check and charge indicators. Features independent on/off switch which allows the positive clamp to be connected with out the risk of sparking. Also fitted with an integral Krypton work light for use at night. Fitted with 12Volt power socket that will accept any 12Volt device fitted with a cigarette lighter type plug. Supplied with mains charger and double plug adaptor for in-car charging. RS132 has integral air compressor with pressure gauge for accurately topping/pumping up tyres etc.

3. SPECIFICATION

RS131.V3

Model: RS131.V3 & RS132
 Cold cranking amps: 200A
 Peak amps: 900A
 Voltage: 12V
 Auxillary output: 12V
 Cable and clamp length: 780mm
 Built in compressor (RS132 only): yes
 Max pressure: 80psi
 Weight: (RS131.V3) 5.9kg (RS132) 6.5kg

4. PRODUCT FEATURES

(Key to figs. 1,2,3 & 4)

- 1) MOULDED RUBBER PROTECTION
- 2) HEAVY DUTY COPPER CABLE (POSITIVE+)
- 3) 12VDC OUTPUT SOCKET
- 4) 12VDC OUTPUT ON/OFF SWITCH
- 5) BATTERY CHECK BUTTON
- 6) LED CHARGE STATE INDICATORS
- 7) AC CHARGING SOCKET
- 8) KRYPTON WORK LIGHT
- 9) WORK LIGHT SWITCH
- 10) HEAVY DUTY COPPER CABLE (NEGATIVE+)
- 11) COMPOSITE CASING
- 12) COMPRESSOR CASING (RS132 only)
- 13) VALVE CONNECTOR (RS132 only)
- 14) NEGATIVE (-) BATTERY CLAMP (BLACK)
- 15) COMPRESSOR PRESSURE GAUGE (RS132 only)
- 16) COMPRESSOR ON/OFF SWITCH (RS132 only)
- 17) POSITIVE (+) BATTERY CLAMP (RED)
- 18) POSITIVE (+) BATTERY CLAMP SAFETY SWITCH



fig.1

RS132



fig.2



5. CHARGING INSTRUCTIONS

WARNING! YOU MUST FOLLOW THE SAFETY INSTRUCTIONS



5.1. INITIAL CHARGING OF THE ROADSTART UNIT

NOTE: This product may arrive partially charged. The unit must be fully charged immediately after purchase and before using for the first time.

5.1.1. The unit should be charged using the AC charger supplied (see fig.6) for a period of 38 hours. Subsequent charges using the AC Charger should be for a period of 34 to 36 hours. Never charge the unit for more than 40 hours.

5.1.2. The unit may also be subsequently charged from a 12V DC cigarette socket in a vehicle for a period of 12 to 14 hours.

☐ **WARNING! Do not** overcharge this unit as this could cause damage to the battery and invalidate the warranty.

5.1.3. To prevent overcharging the user is required to monitor the progress of the charge by pressing the Battery Check Button at regular intervals (see fig.5).

5.2. READING THE LED POWER LEVEL INDICATORS See fig.5

5.2.1. The charge level of the unit during use can be seen at any time by pressing the Battery Check Button and noting which power level lights that are illuminated.

5.2.2. When both green LEDs are illuminated the unit is fully charged and is ready to be used for starting a vehicle.

5.2.3. If only one green LED is illuminated the unit is partially discharged but can be used to operate most 12 volt accessories.

5.2.4. If only the yellow LED is illuminated the power level is low and only a short operating time remains. The unit should be recharged as soon as practical.

5.2.5. If there is only one red light illuminated the unit cannot be used and must be recharged immediately.

5.2.6. To gain an accurate reading of battery status, press the Battery Check Button.

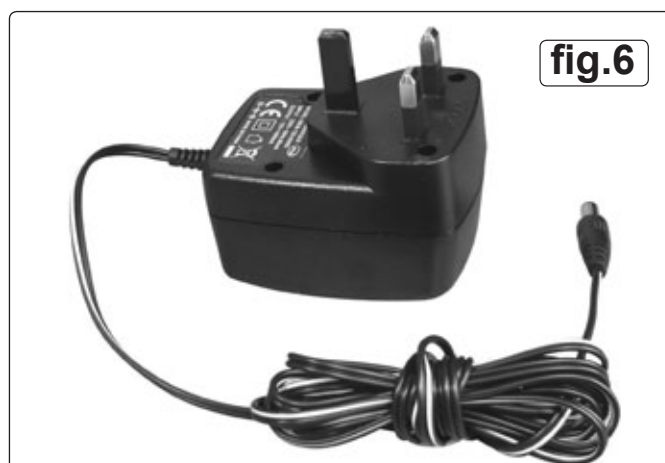
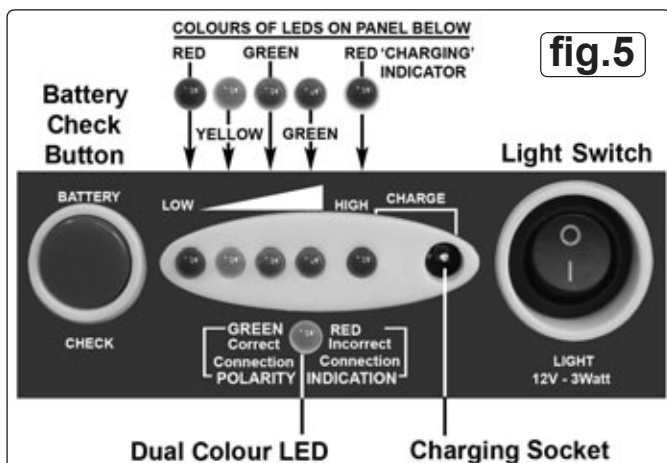

5.3. RECHARGING WITH THE AC CHARGING ADAPTOR

Note: Only charge with the adaptor supplied with your specific model. Charging adaptors are not interchangeable.

5.3.1. Ensure the battery clamps are securely attached to the clamping bars on the unit as shown in figs.2 & 4. Turn the safety switch on the side of the unit to OFF as shown in figs.3 & 4.

5.3.2. Plug the AC charger cable into the charging socket on the front control panel. See fig.5.

5.3.3. Plug the charger itself into any 230 Volt AC wall outlet. The red 'Charging' indicator will illuminate, see fig.5. Charging will now commence but the charge level must be regularly monitored to prevent overcharging. Monitor the charge by pressing the Battery Check Button.

5.3.4. Charging a unit with a very low charge (i.e.showing 1 red LED only) should take 34 to 36 hours. When the two green charge

indicators are illuminated the unit is fully charged and the charger should be disconnected from the unit and from the AC supply.

5.4. RECHARGING WITH THE DC CHARGING CABLE

- ▲ **IMPORTANT:** Always ensure that the vehicle voltage matches the voltage of the Roadstart unit. Do not operate any of the units functions during the charging process.

- 5.4.1. Ensure the battery clamps are securely attached to the clamping bars on the unit as shown in figs.2 & 4. Turn the safety switch on the side of the unit to OFF as shown in figs.3 & 4.
- 5.4.2. With the vehicle engine running plug the DC charging cable into the charging socket on the unit (see fig.5) and then the other end into the vehicle cigarette lighter socket. The unit will be charged by the alternator.
- 5.4.3. The red 'Charging' indicator will illuminate, see fig.5. Charging will now commence but the charge level must be regularly monitored to prevent overcharging. Charging a battery in this way with a very low charge (showing 1 red LED only) should take 12 to 14 hours.
- 5.4.4. When the two green charge indicators are illuminated, when the Battery Check Button is pressed, the unit is fully charged and the charger cable should be disconnected from the unit and from the vehicle.
Do not leave a discharged unit connected to the vehicle if the engine is not running. To do so will discharge the vehicle battery.



fig.7

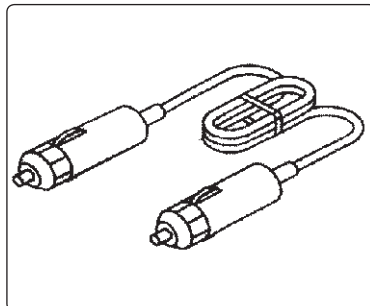

fig.8

6. OPERATION

WARNING! YOU MUST FOLLOW THE SAFETY INSTRUCTIONS



6.1. PREPARATION AND PRECAUTIONS

- **WARNING! ENSURE THAT THE ROADSTART AND VEHICLE VOLTAGES ARE THE SAME.**
- 6.1.1. Apply the vehicle hand brake and place in neutral gear (or "Park" if automatic transmission). Turn ignition and electrical accessories off. **NOTE:** Some vehicle ignition systems must be turned to "Accessory" to activate the cigarette lighter socket.
- 6.1.2. Use in a well ventilated area and wear protective eye shields and clothing.
NOTE: A defective battery may not accept a charge from the portable power source.
- **WARNING!** Do not allow the red and black clamps to touch each other. Ensure that the correct clamps are placed on the correct battery terminals. Observe the Polarity Indication on the control panel. If the dual colour LED is green the connection is correct. If the LED is red do not proceed until the connections are correct.

6.2. BOOSTING A VEHICLE BATTERY

- 6.2.1. Plug one end of the 12V DC plug to plug lead (see fig.8). into the socket on the RoadStart unit.
- 6.2.2. Plug the other end into the vehicle cigarette lighter socket. Allow the vehicle battery to charge for thirty minutes.
- 6.2.3. Remove the charging lead and start the vehicle.
- 6.2.4. Press the Battery Check Button to assess the state of charge of the unit and recharge if required.

6.3. EMERGENCY JUMP STARTING

- **WARNING!** Vehicles equipped with on board computers may be affected if the engine battery is jump started. Read your vehicle owner's manual before attempting to start the vehicle to determine if external starting assistance can be used. Failure to follow these instructions may cause damage or explosion.
NOTE: For optimum performance, the unit should not be stored below 10°C when using the unit as a jump starter.
- ▲ **IMPORTANT:** The unit will only jump start a vehicle if the vehicle battery voltage is greater than 7V. If the battery is delivering less than 7V, refer to Section 6.2 and follow the instructions to boost the vehicle battery.

- 6.3.1. Turn off the vehicle ignition.
- 6.3.2. Determine whether your vehicle uses a negative or a positive earthing system. If you are unsure refer to the owners manual provided with the vehicle.

- 6.3.3. **Negative earthing** - The negative battery terminal is grounded to the vehicle's chassis. Most vehicles use this system.
- 6.3.4. **Positive earthing** - The positive battery terminal is grounded to the vehicle's chassis.

6.4. CONNECTIONS FOR NEGATIVE EARTHED VEHICLE

- 6.4.1. Attach the RED (positive +) clamp to the positive terminal of the battery.
Note: On vehicles with multiple batteries connect positive clamp to positive battery terminal which is connected to vehicle electrical system.
- 6.4.2. Attach the BLACK (negative -) clamp to the vehicle chassis, engine block or a non-moving metal part of the vehicle which is verified to be grounded. Do not clamp directly to the negative battery terminal, carburetor, fuel lines, or sheet metal body parts.

6.5. CONNECTIONS FOR POSITIVE EARTHED VEHICLE

- 6.5.1. Attach the BLACK (negative -) clamp to the negative ungrounded terminal of the battery.
- 6.5.2. Attach the RED (positive +) clamp to the vehicle chassis, engine block or a non-moving metal part of the vehicle which is verified to be grounded. Do not clamp directly to the positive battery terminal, carburetor, fuel lines, or sheet metal body parts.
- 6.5.3. Once the cables are correctly connected turn the rotary switch to the ON position. See figs.3 & 4.

6.6. JUMP STARTING OPERATION

- 6.6.1. Disconnect any accessories plugged into the 12V power outlet.
 - **WARNING!** Do not place the unit where it will become unstable when the engine starts. Route power cables away from moving parts such as fans and belts.

- 6.6.2. Press the battery check button. If the green lights do not illuminate the unit must be charged before it can be used for jump starting.
- 6.6.3. Ensure that all cables are clear of moving belts and rotating fans.
- 6.6.4. Maintain a safe distance from the battery whilst jump starting.
- 6.6.5. Turn on the ignition to start the vehicle.

NOTE: If the vehicle does not start after 4 to 5 seconds, allow the RoadStart unit to cool for 3 to 4 minutes, before attempting to jump start the vehicle again. If this is not done, the unit could sustain damage.

- 6.6.6. When the vehicle has started turn the rotary switch to OFF and disconnect the clamps in reverse order to the connection sequence.
- 6.6.7. For negative earthed systems, disconnect the negative (black) clamp first, then disconnect the positive (red) clamp.
- 6.6.8. For positive earthed systems, disconnect the positive (red) clamp first, then disconnect the negative (black) clamp.
- 6.6.9. Return the clamps to the mounting bars at the back of the casing.
- 6.6.10. Recharge the unit at the first available opportunity.

6.7. ALTERNATIVE VEHICLE POWER SUPPLY

- 6.7.1. When a vehicle battery is disconnected, the memory systems in radios, electronic ignition systems and alarms are frequently lost.
- 6.7.2. When replacing a battery the RoadStart unit can be used as an alternative power supply by connecting the units 12V DC extension lead (fig.8) into the cigarette lighter socket. This will prevent loss of memory in the systems outlined in Paragraph 6.7.1.

- ☐ **WARNING!** The vehicle positive battery cable will be live and **MUST** be insulated (e.g. in a heavy duty plastic bag).

6.8. MULTIPURPOSE POWER SUPPLY

- 6.8.1. This RoadStart unit can be used as a multipurpose power supply to power up any equipment which can connect via a 12V DC cigarette lighter plug. (17amp maximum).
- 6.8.2. Open the socket cover and plug in the lead from the appliance/accessory.
- 6.8.3. Activate the socket by moving the switch above it to the ON position. The appliance operating time will depend on the state of charge of the battery and the amount of current drawn by the appliance. Periodically check the battery status. If only the red light comes on recharge the unit as soon as possible.
- 6.8.4. The socket is protected by a circuit breaker which will trip if the current exceeds 17amps. After 15 to 20 minutes cooling time the circuit breaker will automatically reset.
- 6.8.5. **DO NOT** plug a cigarette lighter into the socket on the unit.

6.9. USING THE WORKLIGHT

- 6.9.1. To turn the worklight ON and OFF use the switch on the left hand side of the lense. If used on its own the light will operate for up to 40 hours on a fully charged battery. Turn OFF light when not required to conserve battery power.
- 6.9.2. The light uses a 12V 3watt bulb. To replace the bulb firstly ensure that the light switch is OFF. Then undo the two screws at the top and bottom of the lens. Prise out the lens. Replace bulb with same type and reassemble the lens to the case.

7. USING THE COMPRESSOR

- ☐ **WARNING!** Check the manual for items to be inflated to obtain the manufacturers recommended inflation pressure. Avoid over inflation.

7.1. INFLATING TYRES

- 7.1.1. Pull the air hose from the stowage track at the back edge of the compressor (see fig.3) and ensure that the locking lever on the valve connector is in the upright position i.e. in line with the connector. See fig.9.
- 7.1.2. Remove the screw cap from tyre valve stem.
- 7.1.3. Push the connector as far as possible onto the valve stem and push the locking lever through 90° to lock it.
- 7.1.4. Switch on the compressor using the switch on the unit (see fig.2-16) and monitor the pressure on the air pressure gauge (see fig.2-15).
- 7.1.5. When the desired pressure is reached, turn off the compressor, rotate the connector lever to the upright position and remove it from the valve stem.

NOTE: It is recommended to use a separate air gauge to double check the actual inflation pressure achieved.

- 7.1.6. Screw the cap back onto the valve stem.

7.2. INFLATING PLASTIC INFLATABLE ITEMS e.g. balls, air beds, rubber rafts etc.

- 7.2.1. Check the manual for items to be inflated to obtain the manufacturer's recommended inflation pressure.
- 7.2.2. Identify valve on product and remove any cover fitted.

- ☐ **WARNING!** Check the manual for items to be inflated to obtain the manufacturer's recommended inflation pressure. Avoid over inflation.

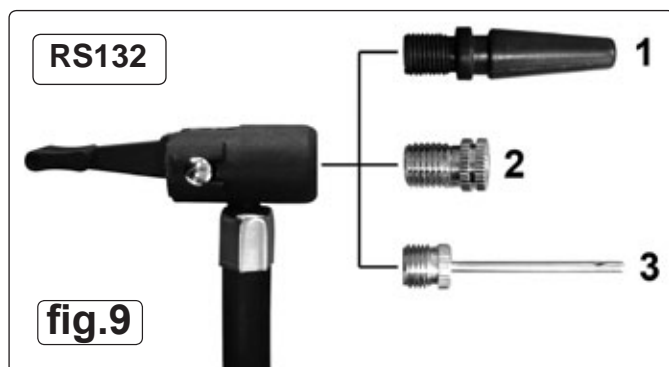

- 7.2.3. Identify the correct adaptor for the product and insert it into the inflation connector as indicated in fig.9 and push the locking lever through 90° to lock it.
- 7.2.4. Insert the other end of the adaptor into the valve as far as possible.
- 7.2.5. Switch on the compressor using the switch on the unit (see fig.2-16) and monitor the pressure on the air pressure gauge (see fig.2-15).
- 7.2.6. When the desired pressure is reached, turn off the compressor, rotate the connector lever to the upright position and remove it

from the valve stem.

NOTE: It is recommended to use a separate air gauge to double check the actual inflation pressure achieved.
Replace any valve cover previously removed.

8. STORAGE

8.1. STORAGE

- 8.1.1. This unit may be stored in any position. Ensure that the clamps are securely attached to the clamping posts at the rear of the unit. Store at room temperature. It is recommended to recharge the unit every three months when not in use and more frequently in warmer or colder storage conditions to keep the battery in peak operating condition.

9. BATTERY REMOVAL/DISPOSAL

NOTE: The RoadStart battery is a sealed, lead-acid type. At the end of the RoadStart's service life, by law, it must be removed and recycled, or disposed of properly, according to national and/or local regulations.

9.1. REMOVAL

- 9.1.1. Place the RoadStart unit front side down.
9.1.2. Remove the 11 screws holding the casing together and lift off the back half of the unit.
9.1.3. Undo and remove the nuts, bolts and washers on each battery terminal. The connecting wires will now be loose.
9.1.4. Move the wires away from the two battery terminals, taking care to avoid accidental arcing of the terminals.
9.1.5. Lift the battery out of the front half of the casing.

9.2. DISPOSAL

- 9.2.1. Take the battery to a recycling centre that handles sealed, lead-acid batteries.
9.2.2. If there is no recycling centre in the area, contact the local environmental agency for disposal instructions.

10. TROUBLESHOOTING

THE PROBLEM	THE SOLUTION
Unit has been charged for 36 hours but there is no change in the status of the LEDs	Check charger to see that it is charging. Charger should be warm. Check all wire connections
Charger works well but still no change in LED status.	Possible defective internal battery.
No LEDs come on, but when the AC adaptor is plugged into the unit they do.	Roadstart unit battery defective which could have been caused by intense use without a cool-down period.
Roadstart unit is fully charged but delivers no power.	Check where the wires meets the jaw on the unit clamps. Ensure they are well crimped. Ensure that the safety switch is in the ON position.
When connecting an accessory via the dc outlet there is no power.	The accessory is drawing too much current, resulting in the internal circuit breaker operating. Allow to cool and reset. Check accessory current draw.

QUESTION	ANSWER
How many jump starts can a fully charged RoadStart do before needing to be recharged?	Between 1 and 20 depending upon operating factors such as temperature, general condition of the vehicle, engine type and size.
Can the RoadStart be recycled?	Yes, in accordance with national and local authority regulations.
What is the ideal in-use storage temperature of the RoadStart?	Room temperature. The RoadStart will also operate at lower temperatures, its power however will be lessened. Intense heat will activate self-discharge.
I have a regular 10 amp battery charger, can I use it to recharge the RoadStart?	No. Only the supplied charger can be used.
Is the RoadStart fool proof?	No. All jump starting instructions must be followed carefully.
Can I replace the internal batteries?	Yes, but note that the batteries are not covered by warranty as they are consumable items



Environmental Protection

Recycle unwanted materials instead of disposing of them as waste. All tools, accessories and packaging should be sorted, taken to a recycling centre and disposed of in a manner which is compatible with the environment. When the product becomes completely unserviceable and requires disposal, and dispose of the product according to local regulations.



WEEE Regulations

Dispose of this product at the end of its working life in compliance with the EU Directive on Waste Electrical and Electronic Equipment (WEEE). When the product is no longer required, it must be disposed of in an environmentally protective way. Contact your local solid waste authority for recycling information.



Battery Removal

Undo the eleven screws which hold the casing together and pull the casings apart. Disconnect the battery leads. Under the Waste Batteries and Accumulators Regulations 2009, Jack Sealey Ltd are required to inform potential purchasers of products containing batteries (as defined within these regulations), that they are registered with Valpak's registered compliance scheme. Jack Sealey Ltd's Batteries Producer Registration Number (BPRN) is BPRN00705.

NOTE: It is our policy to continually improve products and as such we reserve the right to alter data, specifications and component parts without prior notice.

IMPORTANT: No liability is accepted for incorrect use of this product.

WARRANTY: Guarantee is 12 months from purchase date, proof of which will be required for any claim.



Sole UK Distributor, Sealey Group.
Kempson Way, Suffolk Business Park,
Bury St. Edmunds, Suffolk.
IP32 7AR



01284 757500



01284 703534



www.sealey.co.uk



sales@sealey.co.uk