

GB	ORIGINAL INSTRUCTIONS	7	UA	ОРИГІНАЛЬНА ІНСТРУКЦІЯ З ЕКСПЛУАТАЦІЇ	49
F	NOTICE ORIGINALE	9	GR	ΠΡΩΤΟΤΥΠΟ ΟΔΗΓΙΩΝ ΧΡΗΣΗΣ	51
D	ORIGINALBETRIEBSANLEITUNG	12	RO	INSTRUCȚIUNI DE FOLOSIRE ORIGINALE	54
NL	ORIGINELE GEBRUIKSAANWIJZING	14	BG	ОРИГИНАЛНО РЪКОВОДСТВО ЗА ЕКСПЛОАТАЦИЯ	57
S	BRUKSANVISNING I ORIGINAL	17	SK	PŔOVODNÝ NÁVOD NA POUŽITIE	60
DK	ORIGINAL BRUGSANVISNING	19	HR	ORIGINALNE UPUTE ZA RAD	63
N	ORIGINAL BRUKSANVISNING	22	SRB	ORIGINALNO UPUTSTVO ZA RAD	65
FIN	ALKUPERÄISET OHJEET	24	SLO	IZVIRNA NAVODILA	68
E	MANUAL ORIGINAL	27	EST	ALGUPÄRANE KASUTUSJUHEND	70
P	MANUAL ORIGINAL	29	LV	ORIĢINĀLĀ LIETOŠANAS PAMĀCĪBA	73
I	ISTRUZIONI ORIGINALI	32	LT	ORIGINALI INSTRUKCIJA	75
H	EREDETI HASZNÁLATI UTASÍTÁS	35	MK	ИЗБОРНО УПАТСТВО ЗА РАБОТА	78
CZ	PŔVODNÍM NÁVODEM K POUŽÍVÁNÍ	38	AL	UDHËZIMET ORIGINALE	81
TR	ORİJİNAL İŞLETME TALİMATI	40	AR	دليل الاستعمال	88
PL	INSTRUKCJA ORYGINALNA	42	FA	راهنمای اصلی	87
RU	ПОДЛИННИК РУКОВОДСТВА ПО ЭКСПЛУАТАЦИИ	45			



1

1611

1200 Watt	 EPTA 01/2003 3,4 kg	 n_0 0-700/min	 M14	 +140mm MAX	 4m RUBBER	220 240 V~ 50-60 Hz
---------------------	----------------------------	------------------------	---------	-------------------	------------------	--

1612

1200 Watt	 EPTA 01/2003 3,8 kg	 n_0 0-440/ 0-700/min	 M14	 +140mm MAX	 4m RUBBER	220 240 V~ 50-60 Hz
---------------------	----------------------------	-------------------------------	---------	-------------------	------------------	--

2

1611

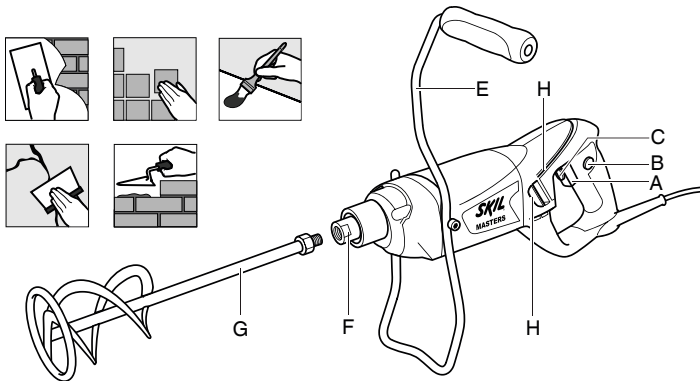

1612

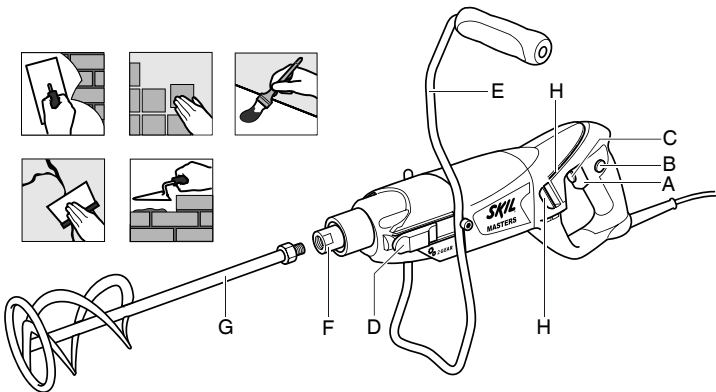

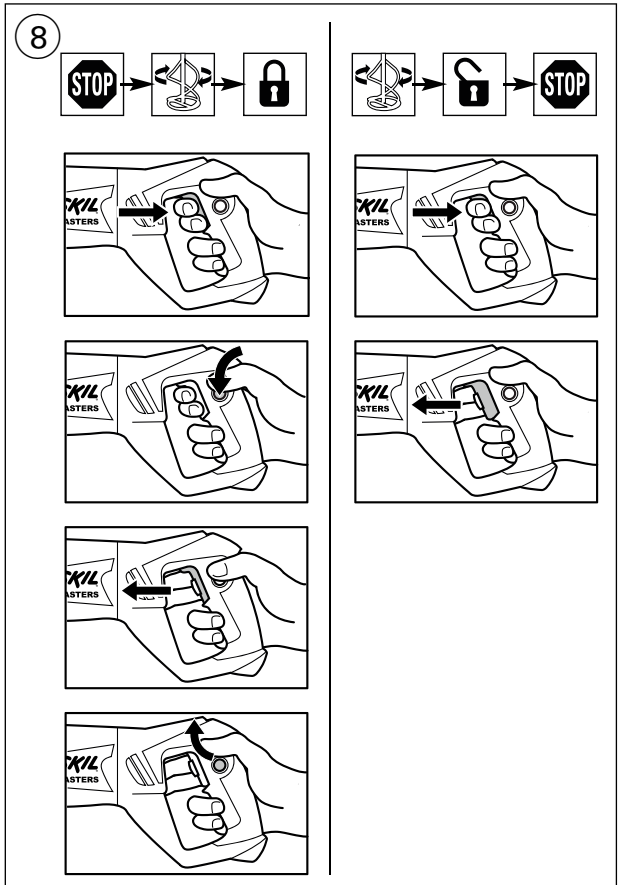
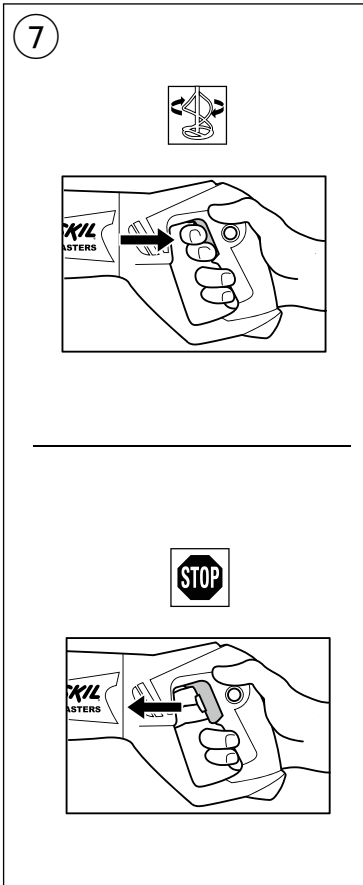
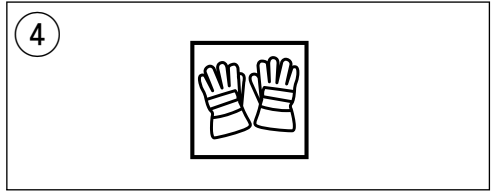
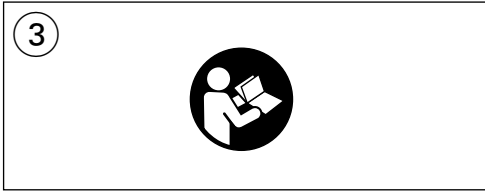

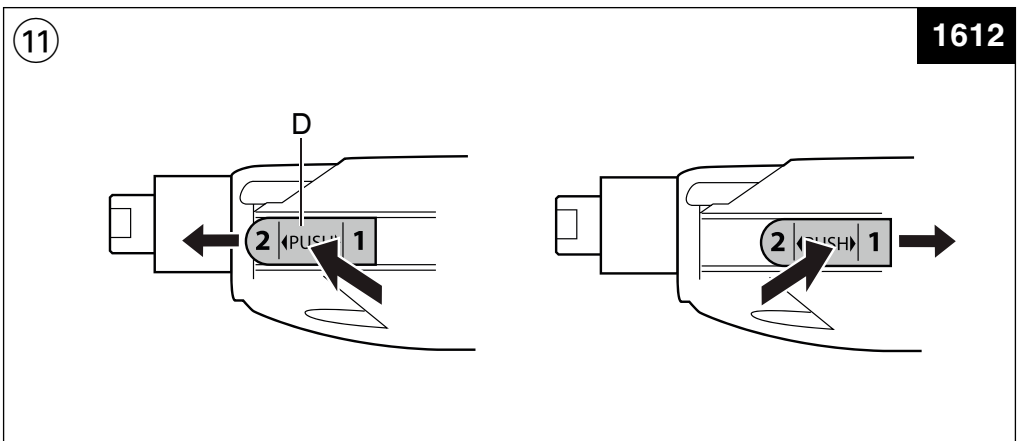
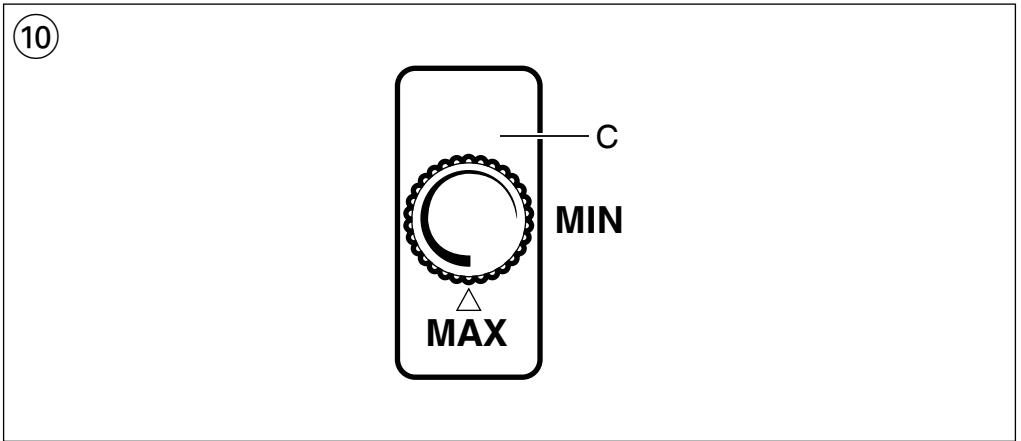
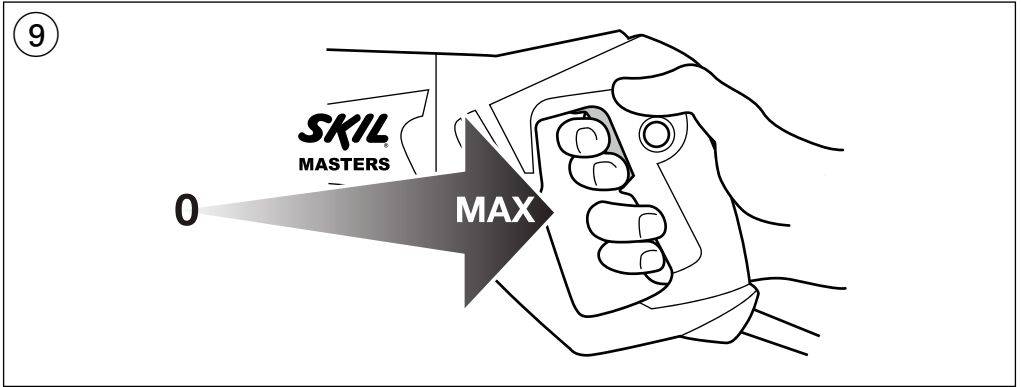

12

1611

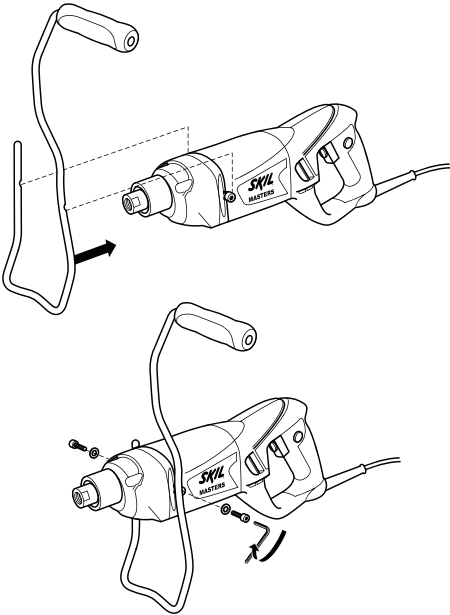

1612

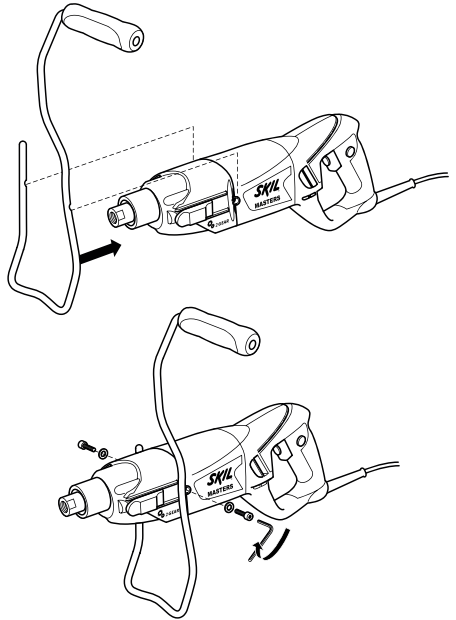

13

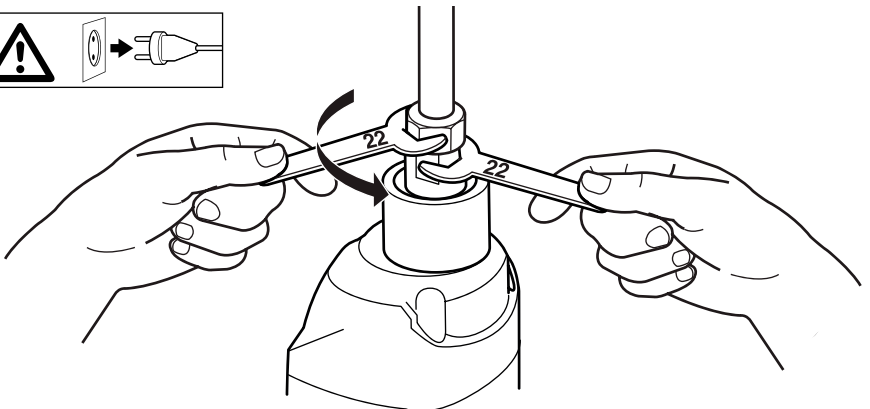
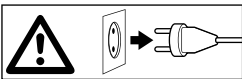

14

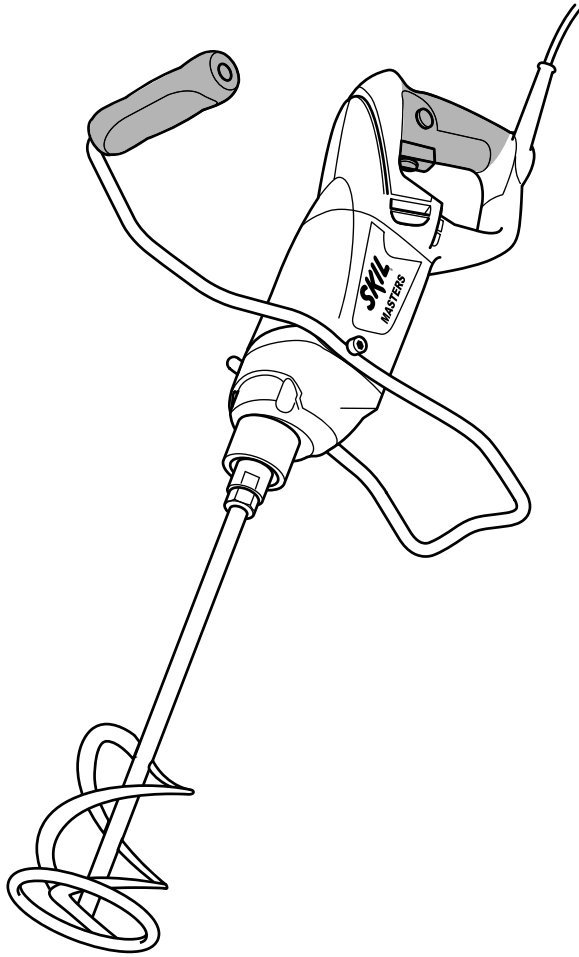

15

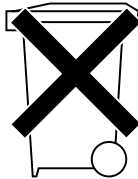

ACCESSORIES



WWW.SKILMASTERS.COM

Mixer

1611/1612

INTRODUCTION

- This electronic mixer is intended for easily and simply mixing substances
- With various mixing paddles a variety of substances (different sorts of cement blends, construction glues, paints, levelling compounds, finishing and dry mortar, etc.) can be mixed
- The recommended blending volume depends on the type and state of the substance to be mixed, and the type of paddle used
- Do not mix more than 40 litres of a substance at one time
- Read and save this instruction manual ③

TECHNICAL SPECIFICATIONS ①

TOOL ELEMENTS ②

- A Switch for on/off and speed control
- B Button for switch locking
- C Wheel for maximum speed control
- D Gear selector (1612)
- E Protection frame
- F Spindle
- G Mixing paddle
- H Ventilation slots

SAFETY

GENERAL SAFETY INSTRUCTIONS

⚠ WARNING! Read all safety warnings and all instructions. Failure to follow the warnings and instructions may result in electric shock, fire and/or serious injury. **Save all warnings and instructions for future reference.** The term "power tool" in the warnings refers to your mains-operated (corded) power tool or battery-operated (cordless) power tool.

1) WORK AREA SAFETY

- a) **Keep work area clean and well lit.** Cluttered or dark areas invite accidents.
- b) **Do not operate power tools in explosive atmospheres, such as in the presence of flammable liquids, gases or dust.** Power tools create sparks which may ignite the dust or fumes.
- c) **Keep children and bystanders away while operating a power tool.** Distractions can cause you to lose control.

2) ELECTRICAL SAFETY

- a) **Power tool plugs must match the outlet. Never modify the plug in any way. Do not use any adapter plugs with earthed (grounded) power tools.** Unmodified plugs and matching outlets will reduce risk of electric shock.
- b) **Avoid body contact with earthed or grounded surfaces such as pipes, radiators, ranges and refrigerators.** There is an increased risk of electric shock if your body is earthed or grounded.

- c) **Do not expose power tools to rain or wet conditions.** Water entering a power tool will increase the risk of electric shock.
- d) **Do not abuse the cord. Never use the cord for carrying, pulling or unplugging the power tool. Keep cord away from heat, oil, sharp edges or moving parts.** Damaged or entangled cords increase the risk of electric shock.
- e) **When operating a power tool outdoors, use an extension cord suitable for outdoor use.** Use of a cord suitable for outdoor use reduces the risk of electric shock.
- f) **If operating a power tool in a damp location is unavoidable, use an earth leakage circuit breaker.** Use of an earth leakage circuit breaker reduces the risk of electric shock.

3) PERSONAL SAFETY

- a) **Stay alert, watch what you are doing and use common sense when operating a power tool. Do not use a power tool while you are tired or under the influence of drugs, alcohol or medication.** A moment of inattention while operating power tools may result in serious personal injury.
 - b) **Use personal protective equipment. Always wear eye protection.** Protective equipment such as dust mask, non-skid safety shoes, hard hat, or hearing protection used for appropriate conditions will reduce personal injuries.
 - c) **Prevent unintentional starting. Ensure the switch is in the off-position before connecting to power source and/or battery pack, picking up or carrying the tool.** Carrying power tools with your finger on the switch or energising power tools that have the switch on invites accidents.
 - d) **Remove any adjusting key or wrench before turning the power tool on.** A wrench or a key left attached to a rotating part of the power tool may result in personal injury.
 - e) **Do not overreach. Keep proper footing and balance at all times.** This enables better control of the power tool in unexpected situations.
 - f) **Dress properly. Do not wear loose clothing or jewellery. Keep your hair, clothing and gloves away from moving parts.** Loose clothes, jewellery or long hair can be caught in moving parts.
 - g) **If devices are provided for the connection of dust extraction and collection facilities, ensure these are connected and properly used.** Use of dust collection can reduce dust-related hazards.
- 4) POWER TOOL USE AND CARE**
- a) **Do not force the power tool. Use the correct power tool for your application.** The correct power tool will do the job better and safer at the rate for which it was designed.
 - b) **Do not use the power tool if the switch does not turn it on and off.** Any power tool that cannot be controlled with the switch is dangerous and must be repaired.
 - c) **Disconnect the plug from the power source and/or the battery pack from the power tool before making any adjustments, changing accessories, or storing power tools.** Such preventive safety measures reduce the risk of starting the power tool accidentally.

- d) **Store idle power tools out of the reach of children and do not allow persons unfamiliar with the power tool or these instructions to operate the power tool.**
Power tools are dangerous in the hands of untrained users.
 - e) **Maintain power tools. Check for misalignment or binding of moving parts, breakage of parts and any other condition that may affect the power tool's operation. If damaged, have the power tool repaired before use.** Many accidents are caused by poorly maintained power tools.
 - f) **Keep cutting tools sharp and clean.** Properly maintained cutting tools with sharp cutting edges are less likely to bind and are easier to control.
 - g) **Use the power tool, accessories and tool bits etc., in accordance with these instructions, taking into account the working conditions and the work to be performed.** Use of the power tool for operations different from those intended could result in a hazardous situation.
- 5) SERVICE**
- a) **Have your power tool serviced by a qualified repair person using only identical replacement parts.** This will ensure that the safety of the power tool is maintained.

SAFETY INSTRUCTIONS FOR MIXERS

- Always check that the supply voltage is the same as the voltage indicated on the nameplate of the tool (tools with a rating of 230V or 240V can also be connected to a 220V supply)
 - Never use the tool without the protection frame
 - Never use the tool in or near an explosive atmosphere
 - Never mix combustible substances
 - Never reach with your hand or any other object into the mixing container during mixing
 - Wear protective gloves (4), a dust mask (5), close-fitting clothes and sturdy shoes
 - The noise level when working can exceed 85 dB(A); **wear ear protection (6)**
 - SKIL can assure flawless functioning of the tool only when the correct accessories are used which can be obtained from your SKIL dealer
 - **Always disconnect plug from power source before making any adjustment or changing any accessory**
- WHEN CONNECTING NEW 3-PIN PLUG (U.K. ONLY):**
- Do not connect the blue (= neutral) or brown (= live) wire in the cord of this tool to the earth terminal of the plug
 - If for any reason the old plug is cut off the cord of this tool, it must be disposed of safely and not left unattended

USE

- On/off (7)
- Switch locking for continuous use (8)
! be aware of the forces that occur as a result of jamming; hold the tool firmly with both hands and take a secure stance
- Speed control for smooth starting (9)
- Maximum speed control (10)
With wheel C the maximum speed can be adjusted from low to high
 - switch on the tool
 - lock the switch
 - turn wheel C to select maximum speed

- Mechanical gear selection (11) (1612)
 - set selector D to desired speed
 - ! actuate the gear selector only when tool is switched off**
 - 1 = LOW SPEED
 - high torque
 - for mixing high-density substances
 - 2 = HIGH SPEED
 - lower torque
 - for mixing liquid substances
- Protection frame (12)
 - for protecting the tool
 - for guiding the tool
 - for putting aside the tool in a simple way
 - mount protection frame E before using the tool for the first time
 - ! never use the tool without the protection frame**
- Operating the tool
 - ! ensure that the tool is switched off**
 - mount mixing paddle G onto spindle F as illustrated (13)
 - connect plug to power source
 - ensure the mixing container is securely positioned on the floor
 - dip the mixing paddle into the blending substance **before switching on the tool**, and then gradually increase the blending speed by putting more pressure on trigger A (2) (so that the substance will not splash around and the tool will not be overloaded)
 - ! switch the tool off only when the mixing paddle is in the mixing container**
- Holding and guiding the tool (14)
 - ! while working, always hold the tool at the grey-coloured grip area(s)**
 - ! always hold the tool firmly with both hands**

MAINTENANCE / SERVICE

- Always keep tool and cord clean (especially the ventilation slots)
 - always clean the mixer and functional parts after your mixing work
 - clean the tool with a dry, soft cloth (do not use cleaning agents or solvents)
 - clean ventilation slots H (2) regularly with a brush or compressed air
 - ! disconnect the plug before cleaning**
- If the tool should fail despite the care taken in manufacturing and testing procedures, repair should be carried out by an after-sales service centre for SKIL power tools
 - send the tool **undismantled** together with proof of purchase to your dealer or the nearest SKIL service station (addresses as well as the service diagram of the tool are listed on www.skilmasters.com)

ENVIRONMENT

- **Do not dispose of electric tools, accessories and packaging together with household waste material** (only for EU countries)
 - in observance of European Directive 2002/96/EC on waste of electric and electronic equipment and its implementation in accordance with national law, electric tools that have reached the end of their life

must be collected separately and returned to an environmentally compatible recycling facility

- symbol 16 will remind you of this when the need for disposing occurs

CE DECLARATION OF CONFORMITY

- We declare under our sole responsibility that this product is in conformity with the following standards or standardized documents: EN 60745, EN 61000, EN 55014, in accordance with the provisions of the directives 2004/108/EC, 2006/42/EC, 2011/65/EU
- **Technical file at:** SKIL Europe BV (PT-SEU/ENG1), 4825 BD Breda, NL

Marijn van der Hoofden
Operations & Engineering

Olaf Dijkgraaf
Approval Manager

SKIL Europe BV, 4825 BD Breda, NL

29.01.2013

NOISE/VIBRATION

- Measured in accordance with EN 60745 the sound pressure level of this tool is 89 dB(A) and the sound power level 100 dB(A) (standard deviation: 3 dB), and the vibration $K = 2.5 \text{ m/s}^2$ (hand-arm method; uncertainty $K = 1.5 \text{ m/s}^2$)
 - The vibration emission level has been measured in accordance with a standardised test given in EN 60745; it may be used to compare one tool with another and as a preliminary assessment of exposure to vibration when using the tool for the applications mentioned
 - using the tool for different applications, or with different or poorly maintained accessories, may significantly **increase** the exposure level
 - the times when the tool is switched off or when it is running but not actually doing the job, may significantly **reduce** the exposure level
- ! protect yourself against the effects of vibration by maintaining the tool and its accessories, keeping your hands warm, and organizing your work patterns**

F

Mixeur

1611/1612

INTRODUCTION

- Ce mixeur électronique est destiné à mélanger facilement et simplement des substances
- Différentes palettes permettent de mélanger une grande variété de substances (différents types de mélanges de ciment, colles de construction, peintures, composés de nivellement, mortier de finition et mortier sec, etc.)
- Le volume de mélange recommandé dépend du type et de l'état de la substance à mélanger, et du type de palette utilisée

- Ne pas mélanger plus de 40 litres de substance à la fois
- Lisez et conservez ce manuel d'instructions ③

SPECIFICATIONS TECHNIQUES ①

ELEMENTS DE L'OUTIL ②

- A Interrupteur de marche/arrêt et réglage de vitesse
- B Bouton de blocage de l'interrupteur
- C Molette de réglage de la vitesse maximum
- D Commutateur de vitesse (1612)
- E Cadre de protection
- F Arbre
- G Palette à mélanger
- H Fentes de ventilation

SECURITE

INSTRUCTIONS GENERALES DE SECURITE

⚠ ATTENTION! Lisez tous les avertissements de sécurité et toutes les instructions. Ne pas suivre les avertissements et instructions peut entraîner un choc électrique, un incendie et/ou de graves blessures sur les personnes. **Conservez tous les avertissements et toutes les instructions pour pouvoir s'y reporter ultérieurement.** La notion d'"outil électroportatif" dans les avertissements se rapporte à des outils électriques raccordés au secteur (avec câble de raccordement) et à des outils électriques à batterie (sans câble de raccordement).

1) SECURITE DE LA ZONE DE TRAVAIL

- a) **Maintenez l'endroit de travail propre et bien éclairé.** Un lieu de travail en désordre ou mal éclairé augmente le risque d'accidents.
- b) **N'utilisez pas l'appareil dans un environnement présentant des risques d'explosion et où se trouvent des liquides, des gaz ou poussières inflammables.** Les outils électroportatifs génèrent des étincelles risquant d'enflammer les poussières ou les vapeurs.
- c) **Tenez les enfants et autres personnes éloignés durant l'utilisation de l'outil électroportatif.** En cas d'inattention vous risquez de perdre le contrôle sur l'appareil.

2) SECURITE RELATIVE AU SYSTEME ELECTRIQUE

- a) **La fiche de secteur de l'outil électroportatif doit être appropriée à la prise de courant. Ne modifiez en aucun cas la fiche. N'utilisez pas de fiches d'adaptateur avec des appareils avec mise à la terre.** Les fiches non modifiées et les prises de courant appropriées réduisent le risque de choc électrique.
- b) **Evitez le contact physique avec des surfaces mises à la terre telles que tuyaux, radiateurs, fours et réfrigérateurs.** Il y a un risque élevé de choc électrique au cas où votre corps serait relié à la terre.
- c) **N'exposez pas l'outil électroportatif à la pluie ou à l'humidité.** La pénétration d'eau dans un outil électroportatif augmente le risque d'un choc électrique.
- d) **N'utilisez pas le câble à d'autres fins que celles prévues, n'utilisez pas le câble pour porter l'appareil ou pour l'accrocher ou encore pour le débrancher**