

GB	ORIGINAL INSTRUCTIONS	7	UA	ОРИГІНАЛЬНА ІНСТРУКЦІЯ З ЕКСПЛУАТАЦІЇ	82
F	NOTICE ORIGINALE	11	GR	ΠΡΩΤΟΤΥΠΟ ΟΔΗΓΙΩΝ ΧΡΗΣΗΣ	87
D	ORIGINALBETRIEBSANLEITUNG	16	RO	INSTRUCȚIUNI DE FOLOSIRE ORIGINALE	93
NL	ORIGINELE GEBRUIKSAANWIJZING	20	BG	ОРИГИНАЛНО РЪКОВОДСТВО ЗА ЕКСПЛОАТАЦИЯ	97
S	BRUKSANVISNING I ORIGINAL	25	SK	PŔVODNÝ NÁVOD NA POUŽITIE	103
DK	ORIGINAL BRUGSANVISNING	29	HR	ORIGINALNE UPUTE ZA RAD	108
N	ORIGINAL BRUKSANVISNING	34	SRB	ORIGINALNO UPUTSTVO ZA RAD	112
FIN	ALKUPERÄISET OHJEET	38	SLO	IZVIRNA NAVODILA	116
E	MANUAL ORIGINAL	43	EST	ALGUPÄRANE KASUTUSJUHEND	121
P	MANUAL ORIGINAL	48	LV	ORIĢINĀLĀ LIETOŠANAS PAMĀCĪBA	125
I	ISTRUZIONI ORIGINALI	52	LT	ORIGINALI INSTRUKCIJA	131
H	EREDETI HASZNÁLATI UTASÍTÁS	57	AR	دليل الاستعمال	142
CZ	PŔVODNÍM NÁVODEM K POUŽÍVÁNÍ	62	FA	راهنمای اصلی	139
TR	ORİJİNAL İŞLETME TALİMATI	66			
PL	INSTRUKCJA ORYGINALNA	71			
RU	ПОДЛИННИК РУКОВОДСТВА ПО ЭКСПЛУАТАЦИИ	76			



1

5885

2000
Watt

110 V = 1700 W

EPTA 01/2003
7,9 kg

 n_0
5000 /min

4m
RUBBER

220
240
V~
50-60 Hz

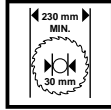
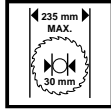
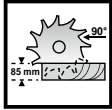

2



3

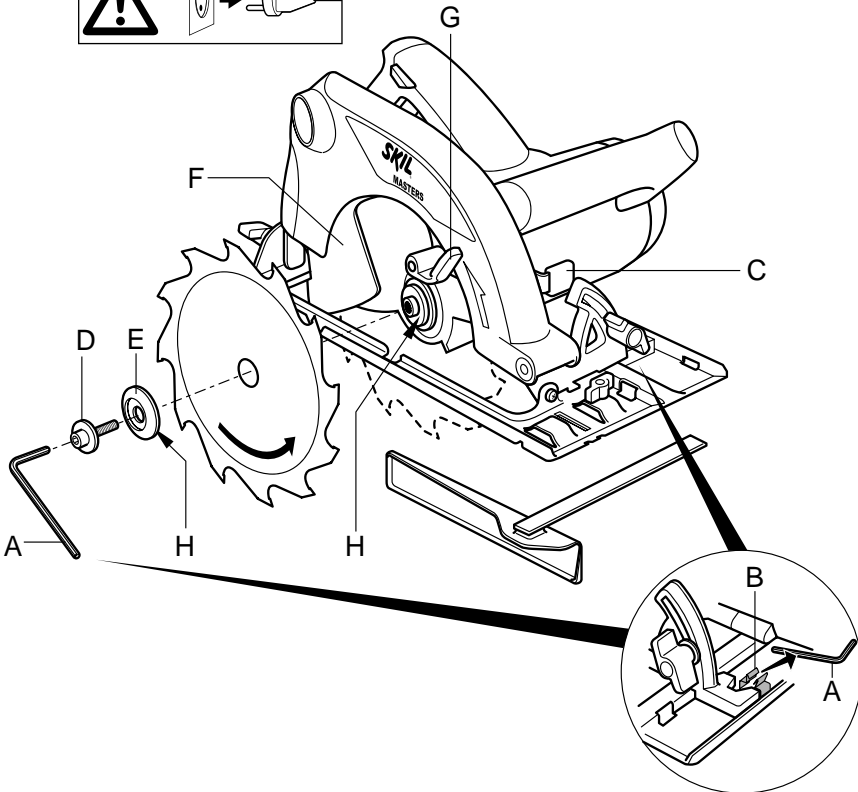
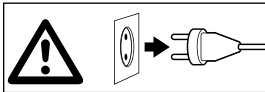

4

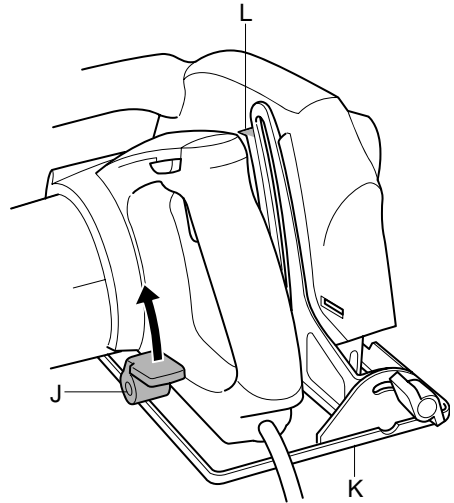
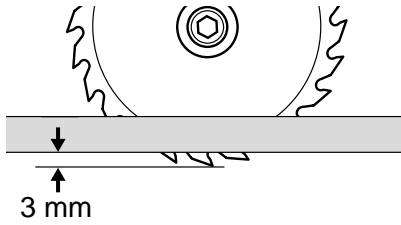
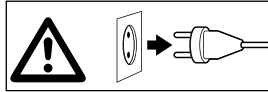

5

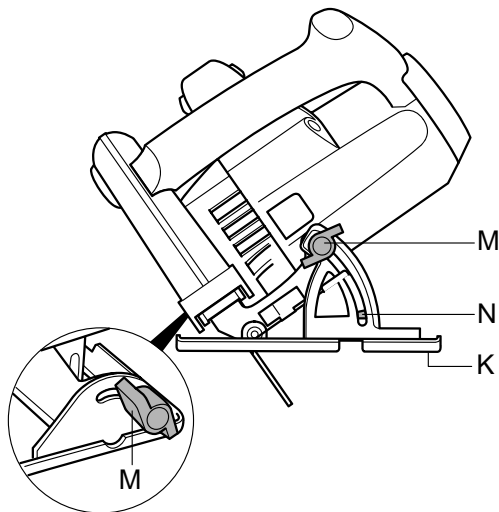
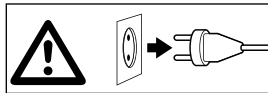

6

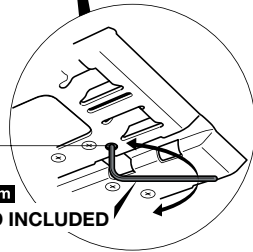
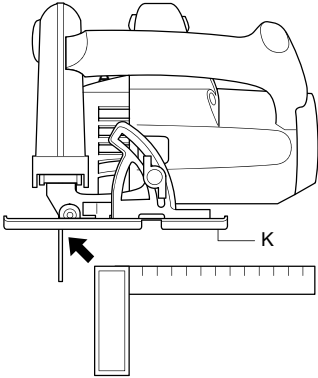
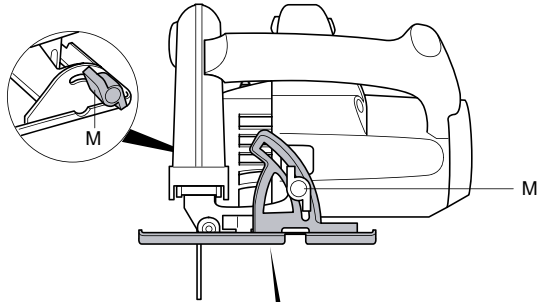
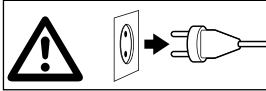

7

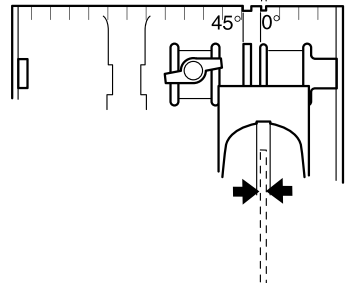
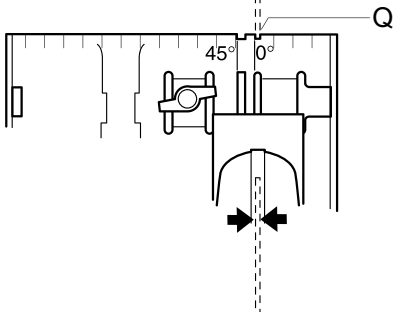
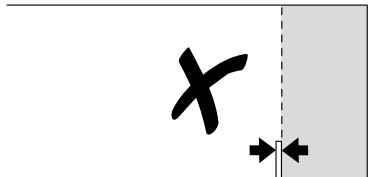

8

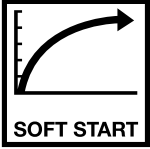

9

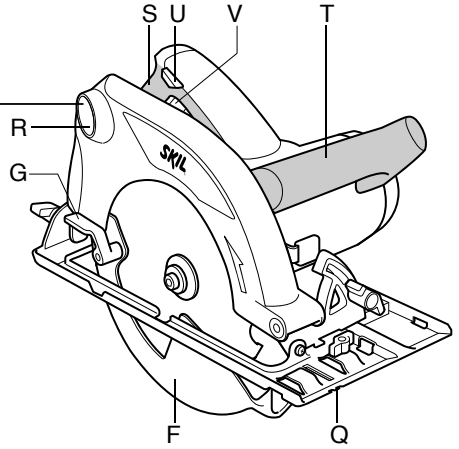
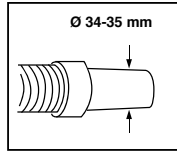

10

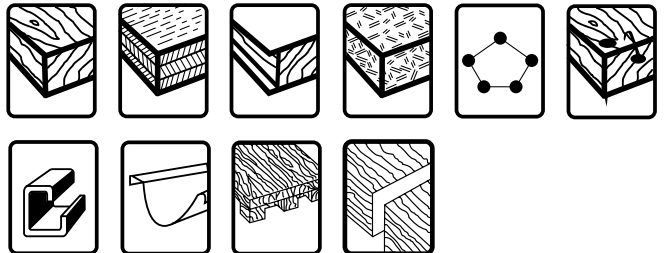
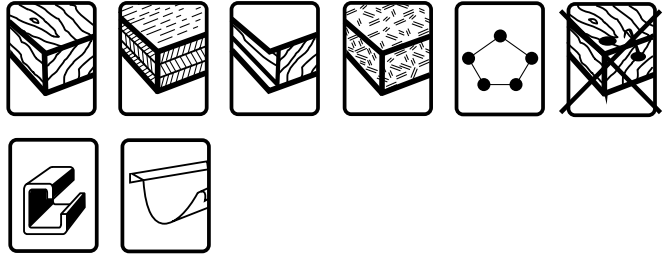
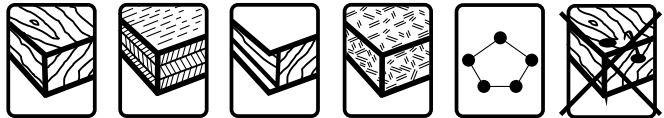

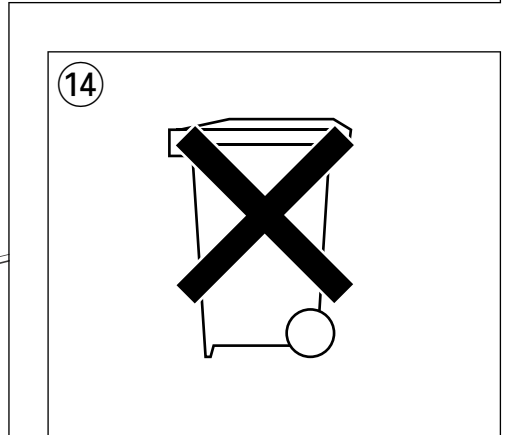
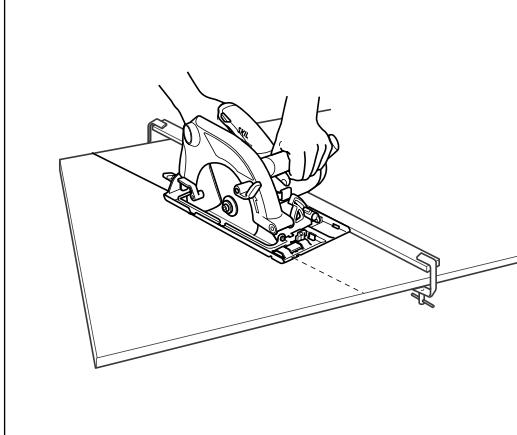
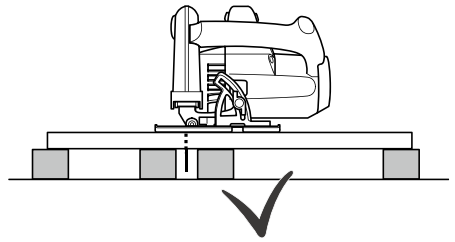
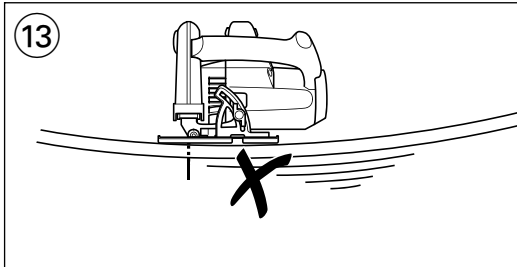
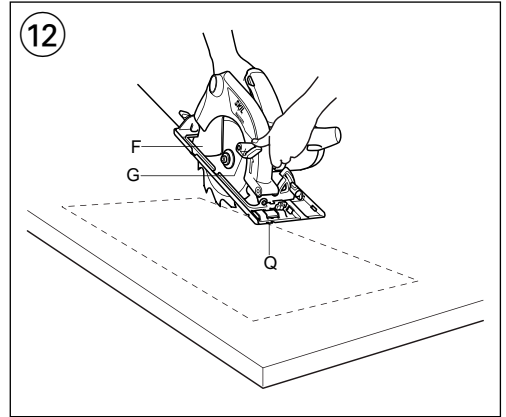
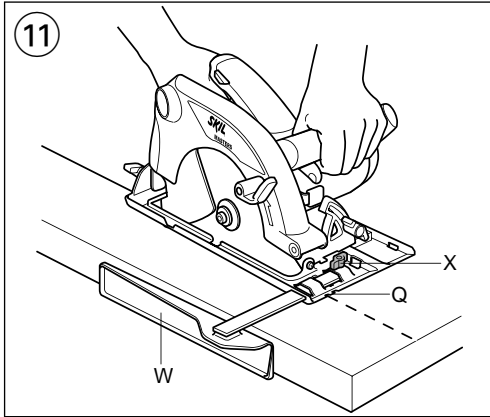

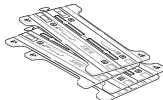
ACCESSORIES	SKIL Nr.
	2610Z00217

INTRODUCTION

- This tool is intended for lengthways and crossways cutting of wood with straight cuts as well as angle cuts up to 45°; with the appropriate saw blades also non-ferrous metals, light building materials and plastics can be cut
- Read and save this instruction manual ②

TECHNICAL SPECIFICATIONS ①

SAFETY

GENERAL SAFETY INSTRUCTIONS

⚠ WARNING! Read all safety warnings and all instructions. Failure to follow the warnings and instructions may result in electric shock, fire and/or serious injury. **Save all warnings and instructions for future reference.** The term "power tool" in the warnings refers to your mains-operated (corded) power tool or battery-operated (cordless) power tool.

1) WORK AREA SAFETY

- Keep work area clean and well lit.** Cluttered or dark areas invite accidents.
- Do not operate power tools in explosive atmospheres, such as in the presence of flammable liquids, gases or dust.** Power tools create sparks which may ignite the dust or fumes.
- Keep children and bystanders away while operating a power tool.** Distractions can cause you to lose control.

2) ELECTRICAL SAFETY

- Power tool plugs must match the outlet. Never modify the plug in any way. Do not use any adapter plugs with earthed (grounded) power tools.** Unmodified plugs and matching outlets will reduce risk of electric shock.
- Avoid body contact with earthed or grounded surfaces such as pipes, radiators, ranges and refrigerators.** There is an increased risk of electric shock if your body is earthed or grounded.
- Do not expose power tools to rain or wet conditions.** Water entering a power tool will increase the risk of electric shock.
- Do not abuse the cord. Never use the cord for carrying, pulling or unplugging the power tool. Keep cord away from heat, oil, sharp edges or moving parts.** Damaged or entangled cords increase the risk of electric shock.
- When operating a power tool outdoors, use an extension cord suitable for outdoor use.** Use of a cord suitable for outdoor use reduces the risk of electric shock.
- If operating a power tool in a damp location is unavoidable, use an earth leakage circuit breaker.** Use of an earth leakage circuit breaker reduces the risk of electric shock.

3) PERSONAL SAFETY

- Stay alert, watch what you are doing and use common sense when operating a power tool. Do not use a power tool while you are tired or under the influence of drugs, alcohol or medication.** A moment of inattention while operating power tools may result in serious personal injury.
- Use personal protective equipment. Always wear eye protection.** Protective equipment such as dust mask, non-skid safety shoes, hard hat, or hearing protection used for appropriate conditions will reduce personal injuries.
- Prevent unintentional starting. Ensure the switch is in the off-position before connecting to power source and/or battery pack, picking up or carrying the tool.** Carrying power tools with your finger on the switch or energising power tools that have the switch on invites accidents.
- Remove any adjusting key or wrench before turning the power tool on.** A wrench or a key left attached to a rotating part of the power tool may result in personal injury.
- Do not overreach. Keep proper footing and balance at all times.** This enables better control of the power tool in unexpected situations.
- Dress properly. Do not wear loose clothing or jewellery. Keep your hair, clothing and gloves away from moving parts.** Loose clothes, jewellery or long hair can be caught in moving parts.
- If devices are provided for the connection of dust extraction and collection facilities, ensure these are connected and properly used.** Use of dust collection can reduce dust-related hazards.

4) POWER TOOL USE AND CARE

- Do not force the power tool. Use the correct power tool for your application.** The correct power tool will do the job better and safer at the rate for which it was designed.
- Do not use the power tool if the switch does not turn it on and off.** Any power tool that cannot be controlled with the switch is dangerous and must be repaired.
- Disconnect the plug from the power source and/or the battery pack from the power tool before making any adjustments, changing accessories, or storing power tools.** Such preventive safety measures reduce the risk of starting the power tool accidentally.
- Store idle power tools out of the reach of children and do not allow persons unfamiliar with the power tool or these instructions to operate the power tool.** Power tools are dangerous in the hands of untrained users.
- Maintain power tools. Check for misalignment or binding of moving parts, breakage of parts and any other condition that may affect the power tool's operation. If damaged, have the power tool repaired before use.** Many accidents are caused by poorly maintained power tools.
- Keep cutting tools sharp and clean.** Properly maintained cutting tools with sharp cutting edges are less likely to bind and are easier to control.
- Use the power tool, accessories and tool bits etc., in accordance with these instructions, taking into account the working conditions and the work to be performed.** Use of the power tool for operations different from those intended could result in a hazardous situation.

5) SERVICE

- Have your power tool serviced by a qualified repair person using only identical replacement parts.** This will ensure that the safety of the power tool is maintained.

SAFETY INSTRUCTIONS FOR CIRCULAR SAWS

DANGER

- **Keep hands away from cutting area and the blade; keep your second hand on front handle** (if both hands are holding the saw, they can not be cut by the blade)
- **Do not reach underneath the workpiece** (the guard cannot protect you from the blade below the workpiece)
- **Adjust the cutting depth to the thickness of the workpiece** (less than a full tooth of the blade teeth should be visible below the workpiece)
- **Never hold piece being cut in your hands or across your leg** (it is important to support the work properly to minimise body exposure, blade binding, or loss of control)
- **Hold tool by insulated gripping surfaces when performing an operation where the cutting tool may contact hidden wiring or its own cord** (contact with a “live” wire will also make exposed metal parts of the tool “live” and shock the operator)
- **When ripping always use a rip fence or straight edge guide** (this improves the accuracy of cut and reduces the chance for blade binding)
- **Always use blades with correct size and shape of arbor holes (diamond or round)** (blades that do not match the mounting hardware of the saw will run eccentrically, causing loss of control)
- **Never use damaged or incorrect blade washers or bolt** (the blade washers and bolt were specially designed for your saw, for optimum performance and safety of operation)

KICKBACK - CAUSES

- Kickback is a sudden reaction to a pinched, bound or misaligned saw blade, causing an uncontrolled saw to lift up and out of the workpiece toward the operator
- When the blade is pinched or bound tightly by the kerf closing down, the blade stalls and the motor reaction drives the unit rapidly back toward the operator
- If the blade becomes twisted or misaligned in the cut, the teeth at the back edge of the blade can dig into the top surface of the wood causing the blade to climb out of the kerf and jump back towards operator

KICKBACK - OPERATOR PREVENTION

- Kickback is the result of tool misuse and/or incorrect operating procedures or conditions and can be avoided by taking proper precautions as given below
- **Maintain a firm grip with both hands on the saw and position your arms to resist kickback forces; position your body to either side of the blade, but not in line with the blade** (kickback could cause the saw to jump backwards, but kickback forces can be controlled by the operator, if proper precautions are taken)
 - **When blade is binding, or when interrupting a cut for any reason, release the trigger and hold the saw motionless in the material until the blade comes to a complete stop; never attempt to remove the saw from the work or pull the saw backwards while the blade is in motion or kickback may occur** (investigate and take corrective actions to eliminate the cause of blade binding; avoid cutting nails or screws)
 - **When restarting a saw in the workpiece, centre the saw blade in the kerf and check that saw teeth are not engaged into the material** (if saw blade is binding, it may walk up or kickback from the workpiece as the saw is restarted)

- **Support large panels to minimise the risk of blade pinching and kickback** (large panels tend to sag under their own weight; supports must be placed under the panel on both sides, near the line of cut and near the edge of the panel)
- **Do not use a dull or damaged blade** (unsharpened or improperly set blades produce narrow kerf causing excessive friction, blade binding and kickback)
- **Blade depth and bevel adjusting locking levers must be tight and secure before making cut** (if blade adjustment shifts while cutting, it may cause binding and kickback)
- **Use extra caution when making a plunge cut into existing walls or other blind areas** (the protruding blade may cut objects that can cause kickback)

WARNING

- **Check lower guard for proper closing before each use**
- **Do not operate the saw if lower guard does not move freely and close instantly**
- **Never clamp or tie the lower guard into the open position**
- If saw is accidentally dropped, lower guard may be bent; disconnect the plug, raise the lower guard with the retracting handle and make sure it moves freely and does not touch the blade or any other part, in all angles and depths of cut
- **Check the operation of the lower guard spring; if the guard and the spring are not operating properly, they must be serviced before use** (lower guard may operate sluggishly due to damaged parts, gummy deposits, or a build-up of debris)
- **Lower guard should be retracted manually only for special cuts such as plunge cuts and compound cuts; raise lower guard by retracting handle and as soon as blade enters the material, the lower guard must be released** (for all other sawing, the lower guard should operate automatically)
- **Always observe that the lower guard is covering the blade before placing saw down on bench or floor** (an unprotected, coasting blade will cause the saw to walk backwards, cutting whatever is in its path; be aware of the time it takes for the blade to stop after switch is released)

GENERAL

- This tool should not be used by people under the age of 16 years
- This tool is not suitable for wet cutting
- **Always disconnect plug from power source before making any adjustment or changing any accessory**
- Never use the tool when cord is damaged; have it replaced by a qualified person
- **Do not work materials containing asbestos** (asbestos is considered carcinogenic)
- Dust from material such as paint containing lead, some wood species, minerals and metal may be harmful (contact with or inhalation of the dust may cause allergic reactions and/or respiratory diseases to the operator or bystanders); **wear a dust mask and work with a dust extraction device when connectable**
- Certain kinds of dust are classified as carcinogenic (such as oak and beech dust) especially in conjunction with additives for wood conditioning; **wear a dust mask and work with a dust extraction device when connectable**

- Follow the dust-related national requirements for the materials you want to work with
- Only use a saw table provided with a switch that prevents restarting of the motor after interruption of voltage
- Only use a saw table provided with a kerf guide

ACCESSORIES

- SKIL can assure flawless functioning of the tool only when the correct accessories are used which can be obtained from your SKIL dealer
- Use only accessories with an allowable speed matching at least the highest no-load speed of the tool
- Never use saw blades made of high speed steel (HSS)
- Never use grinding/cutting discs with this tool

BEFORE USE

- Always check that the supply voltage is the same as the voltage indicated on the nameplate of the tool (tools with a rating of 230V or 240V can also be connected to a 220V supply)
- Avoid damage that can be caused by screws, nails and other elements in your workpiece; remove them before you start working
- Remove all obstacles on top of as well as underneath the cutting path before you start cutting
- **Secure the workpiece** (a workpiece clamped with clamping devices or in a vice is held more securely than by hand)
- **Use suitable detectors to find hidden utility lines or call the local utility company for assistance** (contact with electric lines can lead to fire or electrical shock; damaging a gas line can result in an explosion; penetrating a water pipe will cause property damage or an electrical shock)
- Use completely unrolled and safe extension cords with a capacity of 16 Amps (U.K. 13 Amps)

DURING USE

- The noise level when working can exceed 85 dB(A); wear ear protection
- Never use the tool without the original protection guard system
- Do not attempt to cut extremely small workpieces
- Do not work overhead with the tool
- In case of jamming or electrical or mechanical malfunction, immediately switch off the tool and disconnect the plug
- If the cord is damaged or cut through while working, do not touch the cord, but immediately disconnect the plug

AFTER USE

- When you put away the tool, switch off the motor and ensure that all moving parts have come to a complete standstill
- After switching off your circular saw, never stop the rotation of the saw blade by a lateral force applied against it

WHEN CONNECTING NEW 3-PIN PLUG (U.K. ONLY):

- Do not connect the blue (= neutral) or brown (= live) wire in the cord of this tool to the earth terminal of the plug
- If for any reason the old plug is cut off the cord of this tool, it must be disposed of safely and not left unattended

USE

- Mounting saw blade ③
 - ! **disconnect the plug**
 - take hex key A from storage B
 - push spindle-lock button C and hold it while you remove blade bolt D with hex key
 - ! **push spindle-lock button C only when tool is at a standstill**

- release spindle-lock button C
- remove flange E
- open lower guard F with lever G and hold it while you mount saw blade with saw teeth and arrow printed on saw blade pointing in same direction as arrow on lower guard
- release lower guard F
- mount flange E
- ! **make sure that clamping surfaces H of flanges are perfectly clean and face the blade**
- push spindle-lock button C and hold it while you tighten blade bolt with hex key 1/8 turn past finger tight (ensures slippage of saw blade when it encounters excessive resistance thus reducing motor overload and saw kickback)
- release spindle-lock button C
- Adjusting cutting depth (0-85 mm) ④
 - for an optimal quality cut the saw blade should not extend more than 3 mm below the workpiece
 - loosen lever J
 - raise/lower foot K until desired cutting depth is set on scale using indicator L
 - tighten lever J
- Adjusting cutting angle (0-45°) ⑤
 - loosen 2 knobs M
 - tilt tool until desired cutting angle is set on scale using indicator N
 - tighten 2 knobs M
- ! **when bevel cutting, cutting depth does not correspond with value on cutting depth scale**
- 90° Cutting angle check ⑤
 - adjust and tighten foot K to maximum cutting depth ④
 - adjust and tighten cutting angle to 0°
 - check for a 90° angle between the blade and bottom of foot with a square
 - if adjustment is needed, loosen 2 knobs M and use adjustment screw P as illustrated
- Line-of-cut indicator Q ⑦
 - for guiding tool along desired line of cut marked on the workpiece
 - for a straight 0° cut or a 45° bevel cut use the indicator line concerned
 - allows you to choose whether waste material is on inner or outer side of blade
- ! **the wide part of the foot should rest on the supported part of the workpiece**
- ! **cutting width is determined by width of blade teeth and not by width of blade body**
- ! **always make trial cuts first to verify actual line of cut**
- Electronic soft-start ⑧
 - Ensures reaching the maximum speed smoothly without a sudden impact when tool is switched on
- Dust suction
 - connect vacuum cleaner to extension R ⑨
 - ! **never let the vacuum cleaner hose interfere with the lower guard or the cutting operation**
 - one may also use a dust bag (SKIL accessory 2610387402)
 - ! **do not use dustbag/vacuum cleaner when cutting metal**

- Operating the tool ⑨
 - connect plug to power source
 - always hold handle S firmly with one hand and handle T firmly with the other hand
 - place tool with front end of foot flat on workpiece
 - ! **ensure that the saw teeth are not engaged into the workpiece**
 - switch on tool by first pressing knob U (= safety switch which cannot be locked) and then pulling trigger V
 - ! **the tool should run at full speed before the blade enters into the workpiece**
 - lower guard F opens automatically when saw blade enters the workpiece (open lower guard manually by using lever G only for special cuts such as plunge cuts)
 - do not force the tool; apply light and continuous pressure
 - ! **while working, always hold the tool at the grey-coloured grip area(s)**
 - after completing the cut switch off tool by releasing trigger V
 - ! **ensure that the blade has come to a complete standstill, before you lift the tool from the workpiece**

APPLICATION ADVICE

- Always face the good side of the workpiece down to ensure minimum splintering
- When using guide-rail (accessory 2610Z00217), the depth of cut will be reduced with 9 mm for 90° as well as 45° cuts
- Only use sharp saw blades of the correct type ⑩
 - quality of cut improves by the number of teeth
 - carbide tipped blades stay sharp up to 30 times longer than ordinary blades
- Rip fence W ⑪
 - for making exact cuts along a workpiece edge
 - can be inserted in either side of foot
 Adjusting rip fence
 - loosen knob X
 - adjust to desired cutting width by using rip fence scale (use line-of-cut indicator Q as 0-reference)
 - tighten knob X
- Plunge cutting ⑫
 - set desired cutting depth
 - tilt tool forward with line-of-cut indicator Q lined up with desired line of cut marked on the workpiece
 - open lower guard F with lever G
 - just before blade enters workpiece, switch on tool and gradually lower back end of tool using front end of foot as hinge-point
 - gradually move tool downward as well as forward
 - as soon as blade enters the material, release lever G
 - ! **the tool should run at full speed before the blade enters into the workpiece**
 - ! **never pull tool backwards**
- Cutting large panels ⑬
 - support panel close to the cut either on floor, table or workbench
 - ! **set cutting depth so that you cut through panel and not through support**
 - in case rip fence does not allow desired width of cut, clamp or nail straight piece of wood to workpiece as a guide, and use the right side of the foot against this guide

MAINTENANCE / SERVICE

- Always keep tool and cord clean (especially the ventilation slots)
 - ! **disconnect the plug before cleaning**
- Clean saw blade immediately after use (especially from resin and glue)
- If the tool should fail despite the care taken in manufacturing and testing procedures, repair should be carried out by an after-sales service centre for SKIL power tools
 - send the tool **undismantled** together with proof of purchase to your dealer or the nearest SKIL service station (addresses as well as the service diagram of the tool are listed on www.skilmasters.com)

ENVIRONMENT

- **Do not dispose of electric tools, accessories and packaging together with household waste material** (only for EU countries)
 - in observance of European Directive 2002/96/EC on waste of electric and electronic equipment and its implementation in accordance with national law, electric tools that have reached the end of their life must be collected separately and returned to an environmentally compatible recycling facility
 - symbol ⑭ will remind you of this when the need for disposing occurs

CE DECLARATION OF CONFORMITY

- We declare under our sole responsibility that this product is in conformity with the following standards or standardized documents: EN 60745, EN 61000, EN 55014, in accordance with the provisions of the directives 2006/95/EC, 2004/108/EC, 2006/42/EC
- **Technical file at:** SKIL Europe BV (PT-SEU/PJE), 4825 BD Breda, NL

Arno van der Kloot
Vice President
Operations & Engineering

Jan Trommelen
Approval Manager

SKIL Europe BV, 4825 BD Breda, NL
01.03.2011

NOISE/VIBRATION

- Measured in accordance with EN 60745 the sound pressure level of this tool is 94 dB(A) and the sound power level 105 dB(A) (standard deviation: 3 dB), and the vibration 2.9 m/s² (hand-arm method; uncertainty K = 1.5 m/s²)
- The vibration emission level has been measured in accordance with a standardised test given in EN 60745; it may be used to compare one tool with another and as a preliminary assessment of exposure to vibration when using the tool for the applications mentioned
 - using the tool for different applications, or with different or poorly maintained accessories, may significantly **increase** the exposure level

- the times when the tool is switched off or when it is running but not actually doing the job, may significantly **reduce** the exposure level
- ! **protect yourself against the effects of vibration by maintaining the tool and its accessories, keeping your hands warm, and organizing your work patterns**

F

Scie circulaire

5885

INTRODUCTION

- Cet outil est conçu pour effectuer dans le bois des coupes droites longitudinales et transversales ainsi que des angles d'onglet jusqu'à 45°; muni de lames de scie correspondantes, il est capable de scier des matériaux non-ferreux, des matériaux de construction légers et des matières plastiques
- Lisez et conservez ce manuel d'instruction ②

SPECIFICATIONS TECHNIQUES ①

SECURITE

INSTRUCTIONS GENERALES DE SECURITE

⚠ ATTENTION! Lisez tous les avertissements de sécurité et toutes les instructions. Ne pas suivre les avertissements et instructions peut entraîner un choc électrique, un incendie et/ou de graves blessures sur les personnes. **Conservez tous les avertissements et toutes les instructions pour pouvoir s'y reporter ultérieurement.** La notion d'"outil électroportatif" dans les avertissements se rapporte à des outils électriques raccordés au secteur (avec câble de raccordement) et à des outils électriques à batterie (sans câble de raccordement).

1) SECURITE DE LA ZONE DE TRAVAIL

- Maintenez l'endroit de travail propre et bien éclairé.**
Un lieu de travail en désordre ou mal éclairé augmente le risque d'accidents.
- N'utilisez pas l'appareil dans un environnement présentant des risques d'explosion et où se trouvent des liquides, des gaz ou poussières inflammables.** Les outils électroportatifs génèrent des étincelles risquant d'enflammer les poussières ou les vapeurs.
- Tenez les enfants et autres personnes éloignés durant l'utilisation de l'outil électroportatif.** En cas d'inattention vous risquez de perdre le contrôle sur l'appareil.

2) SECURITE RELATIVE AU SYSTEME ELECTRIQUE

- La fiche de secteur de l'outil électroportatif doit être appropriée à la prise de courant. Ne modifiez en aucun cas la fiche. N'utilisez pas de fiches d'adaptateur avec des appareils avec mise à la terre.** Les fiches non modifiées et les prises de courant appropriées réduisent le risque de choc électrique.

- Evitez le contact physique avec des surfaces mises à la terre telles que tuyaux, radiateurs, fours et réfrigérateurs.** Il y a un risque élevé de choc électrique au cas où votre corps serait relié à la terre.
- N'exposez pas l'outil électroportatif à la pluie ou à l'humidité.** La pénétration d'eau dans un outil électroportatif augmente le risque d'un choc électrique.
- N'utilisez pas le câble à d'autres fins que celles prévues, n'utilisez pas le câble pour porter l'appareil ou pour l'accrocher ou encore pour le débrancher de la prise de courant. Maintenez le câble éloigné des sources de chaleur, des parties grasses, des bords tranchants ou des parties de l'appareil en rotation.** Un câble endommagé ou torsadé augmente le risque d'un choc électrique.
- Au cas où vous utiliseriez l'outil électroportatif à l'extérieur, utilisez une rallonge autorisée homologuée pour les applications extérieures.** L'utilisation d'une rallonge électrique homologuée pour les applications extérieures réduit le risque d'un choc électrique.
- Si l'usage d'un outil dans un emplacement humide est inévitable, utilisez un disjoncteur de fuite à la terre.** L'utilisation d'un disjoncteur de fuite à la terre réduit le risque de choc électrique.

3) SECURITE DES PERSONNES

- Restez vigilant, surveillez ce que vous faites. Faites preuve de bon sens en utilisant l'outil électroportatif. N'utilisez pas l'appareil lorsque vous êtes fatigué ou après avoir consommé de l'alcool, des drogues ou avoir pris des médicaments.** Un moment d'inattention lors de l'utilisation de l'appareil peut entraîner de graves blessures sur les personnes.
- Portez des équipements de protection. Portez toujours des lunettes de protection.** Le fait de porter des équipements de protection personnels tels que masque anti-poussières, chaussures de sécurité antidérapantes, casque de protection ou protection acoustique suivant le travail à effectuer, réduit le risque de blessures.
- Evitez tout démarrage intempestif. S'assurez que l'interrupteur est en position arrêt avant de brancher l'outil au secteur et/ou au bloc de batteries, de le ramasser ou de le porter.** Porter les outils en ayant le doigt sur l'interrupteur ou brancher des outils dont l'interrupteur est en position marche est source d'accidents.
- Enlevez tout outil de réglage ou toute clé avant de mettre l'appareil en fonctionnement.** Une clé ou un outil se trouvant sur une partie en rotation peut causer des blessures.
- Ne surestimez pas vos capacités. Veillez à garder toujours une position stable et équilibrée.** Ceci vous permet de mieux contrôler l'appareil dans des situations inattendues.
- Portez des vêtements appropriés. Ne portez pas de vêtements amples ni de bijoux. Maintenez cheveux, vêtements et gants éloignés des parties de l'appareil en rotation.** Des vêtements amples, des bijoux ou des cheveux longs peuvent être happés par des pièces en mouvement.