



<b>GB</b>	ORIGINAL INSTRUCTIONS	5	<b>UA</b>	ОРИГІНАЛЬНА ІНСТРУКЦІЯ З ЕКСПЛУАТАЦІЇ	89
<b>F</b>	NOTICE ORIGINALE	9	<b>GR</b>	ΠΡΩΤΟΤΥΠΟ ΟΔΗΓΙΩΝ ΧΡΗΣΗΣ	95
<b>D</b>	ORIGINALBETRIEBSANLEITUNG	15	<b>RO</b>	INSTRUCȚIUNI DE FOLOSIRE ORIGINALE	101
<b>NL</b>	ORIGINELE GEBRUIKSAANWIJZING	20	<b>BG</b>	ОРИГИНАЛНО РЪКОВОДСТВО ЗА ЕКСПЛОАТАЦИЯ	106
<b>S</b>	BRUKSANVISNING I ORIGINAL	25	<b>SK</b>	PŔOVODNÝ NÁVOD NA POUŽITIE	113
<b>DK</b>	ORIGINAL BRUGSANVISNING	30	<b>HR</b>	ORIGINALNE UPUTE ZA RAD	118
<b>N</b>	ORIGINAL BRUKSANVISNING	35	<b>SRB</b>	ORIGINALNO UPUTSTVO ZA RAD	123
<b>FIN</b>	ALKUPERÄISET OHJEET	39	<b>SLO</b>	IZVIRNA NAVODILA	128
<b>E</b>	MANUAL ORIGINAL	44	<b>EST</b>	ALGUPÄRANE KASUTUSJUHEND	133
<b>P</b>	MANUAL ORIGINAL	50	<b>LV</b>	ORIĢINĀLĀ LIETOŠANAS PAMĀCĪBA	138
<b>I</b>	ISTRUZIONI ORIGINALI	55	<b>LT</b>	ORIGINALI INSTRUKCIJA	143
<b>H</b>	EREDETI HASZNÁLATI UTASÍTÁS	61	<b>MK</b>	ИЗБОРНО УПАТСТВО ЗА РАБОТА	148
<b>CZ</b>	PŔVODNÍM NÁVODEM K POUŽÍVÁNÍ	67	<b>AL</b>	UDHËZIMET ORIGINALE	154
<b>TR</b>	ORİJİNAL İŞLETME TALİMATI	71	<b>AR</b>	دليل الاستعمال	168
<b>PL</b>	INSTRUKCJA ORYGINALNA	76	<b>FA</b>	راهنمای اصلی	165
<b>RU</b>	ПОДЛИННИК РУКОВОДСТВА ПО ЭКСПЛУАТАЦИИ	82			



1

9425

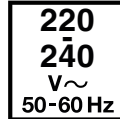
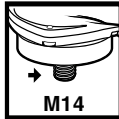
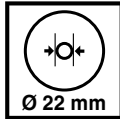
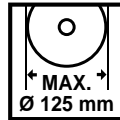
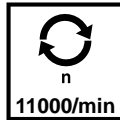
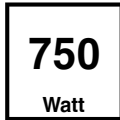

2

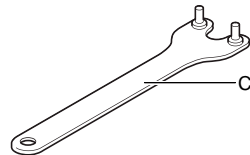
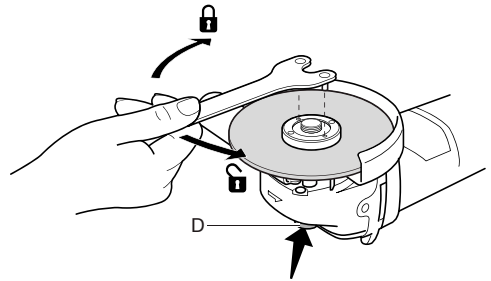
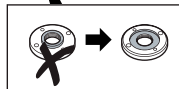
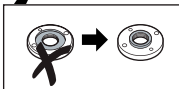
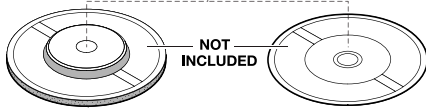
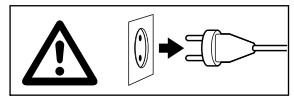
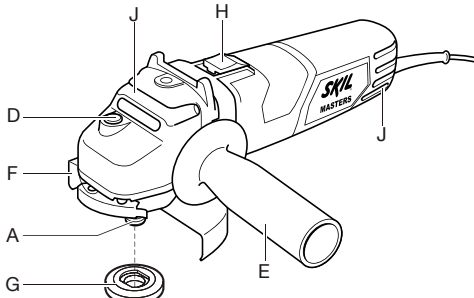

3



4



5

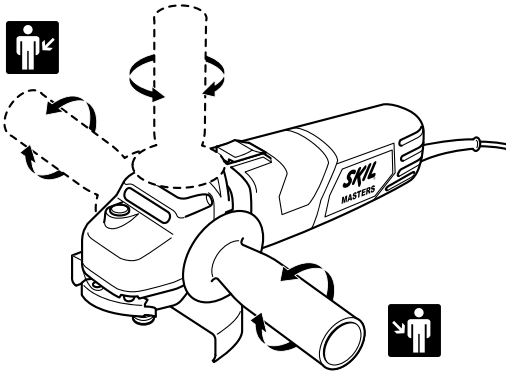

6

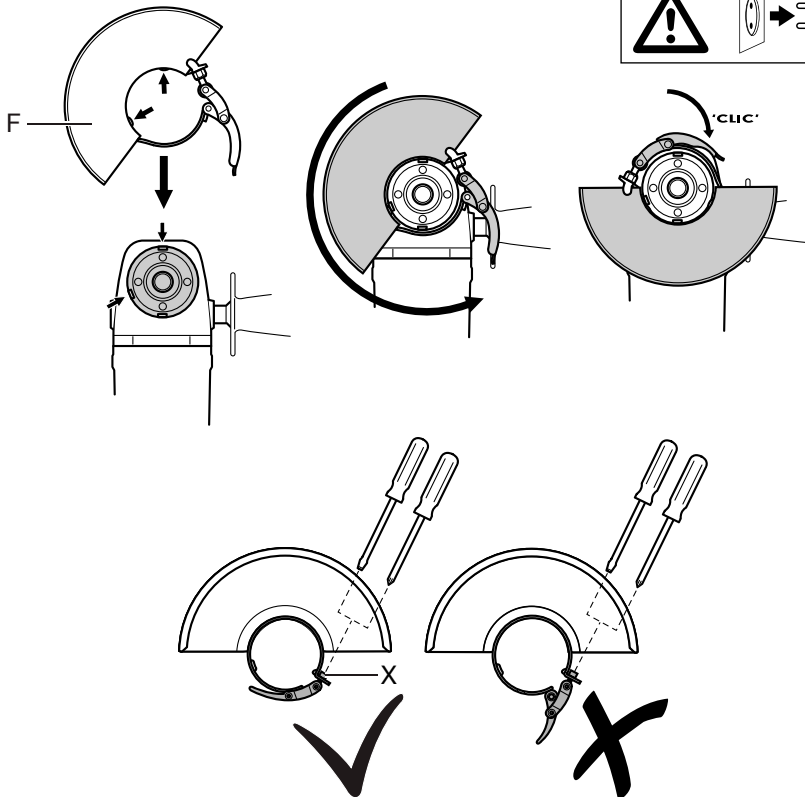

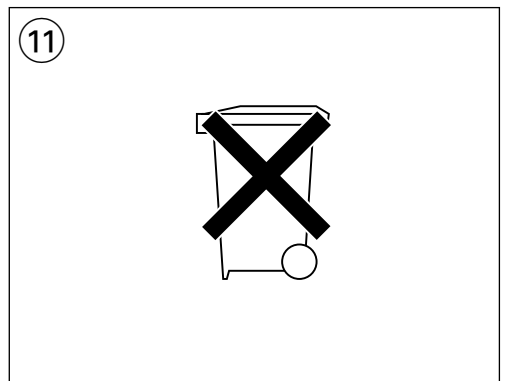
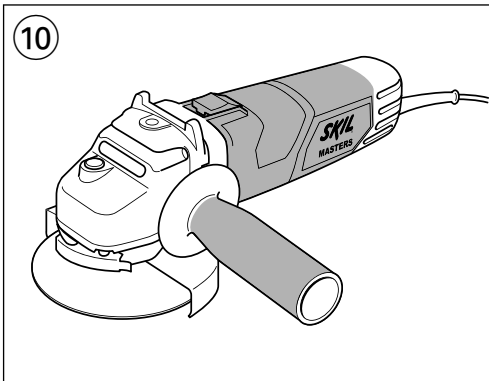
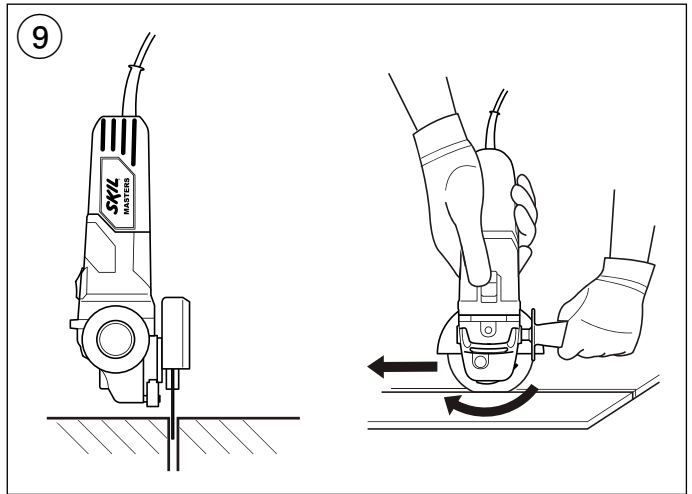
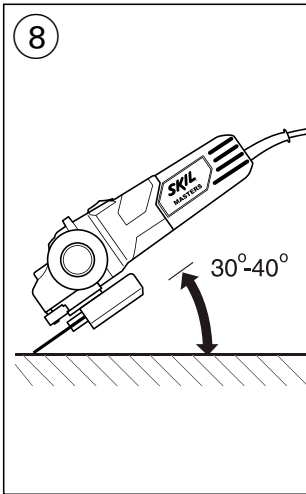
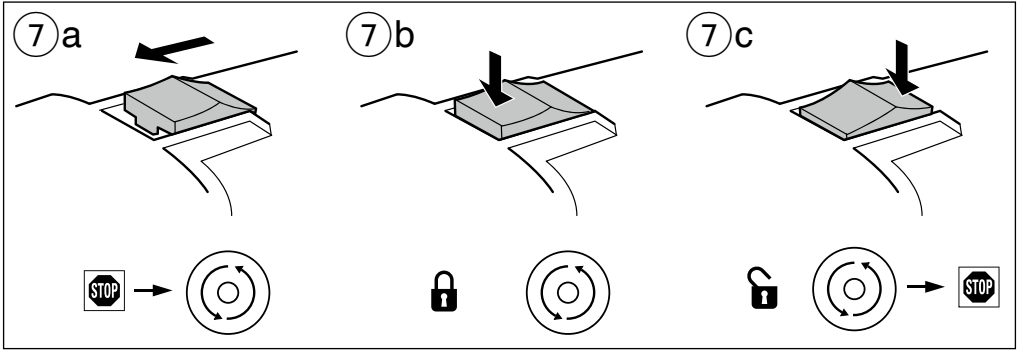

ACCESSORIES → [WWW.SKILMASTERS.COM](http://WWW.SKILMASTERS.COM)

## Angle grinder

9425

### INTRODUCTION

- This tool is intended for grinding, cutting and deburring metal and stone materials without the use of water; with the appropriate accessories the tool can also be used for brushing and sanding
- Cutting operations with abrasive cut-off wheels are only allowed when a cut-off guard (available as optional SKIL accessory 2610Z00995) is used**
- Read and save this instruction manual ③

### TECHNICAL SPECIFICATIONS ①

#### TOOL ELEMENTS ②

- A Spindle
- B Clamping flange
- C Spanner
- D Spindle-lock button
- E Auxiliary handle
- F Protective guard
- G Mounting flange
- H On/off locking switch
- J Ventilation slots

### SAFETY

#### GENERAL SAFETY INSTRUCTIONS

**⚠ WARNING! Read all safety warnings and all instructions.** Failure to follow the warnings and instructions may result in electric shock, fire and/or serious injury. **Save all warnings and instructions for future reference.** The term "power tool" in the warnings refers to your mains-operated (corded) power tool or battery-operated (cordless) power tool.

#### 1) WORK AREA SAFETY

- a) **Keep work area clean and well lit.** Cluttered or dark areas invite accidents.
- b) **Do not operate power tools in explosive atmospheres, such as in the presence of flammable liquids, gases or dust.** Power tools create sparks which may ignite the dust or fumes.
- c) **Keep children and bystanders away while operating a power tool.** Distractions can cause you to lose control.

#### 2) ELECTRICAL SAFETY

- a) **Power tool plugs must match the outlet. Never modify the plug in any way. Do not use any adapter plugs with earthed (grounded) power tools.** Unmodified plugs and matching outlets will reduce risk of electric shock.
- b) **Avoid body contact with earthed or grounded surfaces such as pipes, radiators, ranges and refrigerators.** There is an increased risk of electric shock if your body is earthed or grounded.
- c) **Do not expose power tools to rain or wet conditions.** Water entering a power tool will increase the risk of electric shock.

- d) **Do not abuse the cord. Never use the cord for carrying, pulling or unplugging the power tool. Keep cord away from heat, oil, sharp edges or moving parts.** Damaged or entangled cords increase the risk of electric shock.
  - e) **When operating a power tool outdoors, use an extension cord suitable for outdoor use.** Use of a cord suitable for outdoor use reduces the risk of electric shock.
  - f) **If operating a power tool in a damp location is unavoidable, use an earth leakage circuit breaker.** Use of an earth leakage circuit breaker reduces the risk of electric shock.
- #### 3) PERSONAL SAFETY
- a) **Stay alert, watch what you are doing and use common sense when operating a power tool. Do not use a power tool while you are tired or under the influence of drugs, alcohol or medication.** A moment of inattention while operating power tools may result in serious personal injury.
  - b) **Use personal protective equipment. Always wear eye protection.** Protective equipment such as dust mask, non-skid safety shoes, hard hat, or hearing protection used for appropriate conditions will reduce personal injuries.
  - c) **Prevent unintentional starting. Ensure the switch is in the off-position before connecting to power source and/or battery pack, picking up or carrying the tool.** Carrying power tools with your finger on the switch or energising power tools that have the switch on invites accidents.
  - d) **Remove any adjusting key or wrench before turning the power tool on.** A wrench or a key left attached to a rotating part of the power tool may result in personal injury.
  - e) **Do not overreach. Keep proper footing and balance at all times.** This enables better control of the power tool in unexpected situations.
  - f) **Dress properly. Do not wear loose clothing or jewellery. Keep your hair, clothing and gloves away from moving parts.** Loose clothes, jewellery or long hair can be caught in moving parts.
  - g) **If devices are provided for the connection of dust extraction and collection facilities, ensure these are connected and properly used.** Use of dust collection can reduce dust-related hazards.
- #### 4) POWER TOOL USE AND CARE
- a) **Do not force the power tool. Use the correct power tool for your application.** The correct power tool will do the job better and safer at the rate for which it was designed.
  - b) **Do not use the power tool if the switch does not turn it on and off.** Any power tool that cannot be controlled with the switch is dangerous and must be repaired.
  - c) **Disconnect the plug from the power source and/or the battery pack from the power tool before making any adjustments, changing accessories, or storing power tools.** Such preventive safety measures reduce the risk of starting the power tool accidentally.
  - d) **Store idle power tools out of the reach of children and do not allow persons unfamiliar with the power tool or these instructions to operate the power tool.** Power tools are dangerous in the hands of untrained users.
  - e) **Maintain power tools. Check for misalignment or binding of moving parts, breakage of parts and any**

other condition that may affect the power tool's operation. If damaged, have the power tool repaired before use. Many accidents are caused by poorly maintained power tools.

- f) **Keep cutting tools sharp and clean.** Properly maintained cutting tools with sharp cutting edges are less likely to bind and are easier to control.
  - g) **Use the power tool, accessories and tool bits etc., in accordance with these instructions, taking into account the working conditions and the work to be performed.** Use of the power tool for operations different from those intended could result in a hazardous situation.
- 5) **SERVICE**
- a) **Have your power tool serviced by a qualified repair person using only identical replacement parts.** This will ensure that the safety of the power tool is maintained.

## **SAFETY INSTRUCTIONS FOR ANGLE GRINDERS**

### **1) SAFETY INSTRUCTIONS FOR ALL OPERATIONS**

- a) **This power tool is intended to function as a grinder, sander, wire brush or cut-off tool. Read all safety warnings, instructions, illustrations and specifications provided with this power tool.** Failure to follow all instructions listed below may result in electric shock, fire and/or serious injury.
- b) **This power tool is not recommended for polishing.** Operations for which the power tool was not designed may create a hazard and cause personal injury.
- c) **Do not use accessories which are not specifically designed and recommended by the tool manufacturer.** Just because the accessory can be attached to your power tool, it does not assure safe operation.
- d) **The rated speed of the accessory must be at least equal to the maximum speed marked on the power tool.** Accessories running faster than their rated speed can fly apart.
- e) **The outside diameter and the thickness of your accessory must be within the capacity rating of your power tool.** Incorrectly sized accessories cannot be adequately guarded or controlled.
- f) **The arbour size of wheels, flanges, backing pads or any other accessory must properly fit the spindle of the power tool.** Accessories with arbour holes that do not match the mounting hardware of the power tool will run out of balance, vibrate excessively and may cause loss of control.
- g) **Do not use a damaged accessory. Before each use inspect the accessory such as abrasive wheels for chips and cracks, backing pads for cracks, tear or excess wear, wire brushes for loose or cracked wires. If the power tool or accessory is dropped, inspect for damage or install an undamaged accessory. After inspecting and installing an accessory, position yourself and bystanders away from the plane of the rotating accessory and run the power tool at maximum no load speed for one minute.** Damaged accessories will normally break apart during this test time.
- h) **Wear personal protective equipment (4).** Depending on application, use face shield, safety goggles or safety glasses. As appropriate, wear dust mask, hearing protectors, gloves and shop apron capable

### **of stopping small abrasive or workpiece fragments.**

The eye protection must be capable of stopping flying debris generated by various operations. The dust mask or respirator must be capable of filtering particles generated by your operation. Prolonged exposure to high intensity noise may cause hearing loss.

- i) **Keep bystanders a safe distance away from work area. Anyone entering the work area must wear personal protective equipment.** Fragments of the workpiece or of a broken accessory may fly away and cause injury beyond the immediate area of operation.
- j) **Hold power tool by insulated gripping surfaces only, when performing an operation where the cutting accessory may contact hidden wiring or its own cord.** A cutting accessory contacting a "live" wire may make exposed metal parts of the power tool "live" and could give the operator an electric shock.
- k) **Position the cord clear of the spinning accessory.** If you lose control, the cord may be cut or snagged and your hand or arm may be pulled into the spinning accessory.
- l) **Never lay the power tool down until the accessory has come to a complete stop.** The spinning accessory may grab the surface and pull the power tool out of your control.
- m) **Do not run the power tool while carrying it at your side.** Accidental contact with the spinning accessory could snag your clothing, pulling the accessory into your body.
- n) **Regularly clean the power tool's air vents.** The motor's fan will draw the dust inside the housing and excessive accumulation of powdered metal may cause electrical hazards.
- o) **Do not operate the power tool near flammable materials.** Sparks could ignite these materials.
- p) **Do not use accessories that require liquid coolants.** Using water or other liquid coolants may result in electrocution or shock.

### **2) KICKBACK AND RELATED WARNINGS**

- Kickback is a sudden reaction to a pinched or snagged rotating wheel, backing pad, brush or any other accessory. Pinching or snagging causes rapid stalling of the rotating accessory which in turn causes the uncontrolled power tool to be forced in the direction opposite of the accessory's rotation at the point of the binding.
  - For example, if an abrasive wheel is snagged or pinched by the workpiece, the edge of the wheel that is entering into the pinch point can dig into the surface of the material causing the wheel to climb out or kick out. The wheel may either jump toward or away from the operator, depending on the direction of the wheel's movement at the point of pinching. Abrasive wheels may also break under these conditions.
  - Kickback is the result of power tool misuse and/or incorrect operating procedures or conditions and can be avoided by taking proper precautions as given below.
- a) **Maintain a firm grip on the power tool and position your body and arm to allow you to resist kickback forces. Always use auxiliary handle, if provided, for maximum control over kickback or torque reaction during start-up.** The operator can control torque reactions or kickback forces, if proper precautions are taken.
  - b) **Never place your hand near the rotating accessory.** The accessory may kickback over your hand.

- c) **Do not position your body in the area where power tool will move if kickback occurs.** Kickback will propel the tool in the direction opposite to the wheel's movement at the point of snagging.
- d) **Use special care when working corners, sharp edges etc. Avoid bouncing and snagging the accessory.** Corners, sharp edges or bouncing have a tendency to snag the rotating accessory and cause loss of control or kickback.
- e) **Do not attach a saw chain woodcarving blade or toothed saw blade.** Such blades create frequent kickback and loss of control.
- 3) SAFETY WARNINGS SPECIFIC FOR GRINDING AND CUTTING OFF OPERATIONS**
- a) **Use only wheel types that are recommended for your power tool and the specific guard designed for the selected wheel.** Wheels for which the power tool was not designed cannot be adequately guarded and are unsafe.
- b) **The guard must be securely attached to the power tool and positioned for maximum safety, so the least amount of wheel is exposed towards the operator.** The guard helps to protect the operator from broken wheel fragments, accidental contact with wheel and sparks that could ignite clothing.
- c) **Wheels must be used only for recommended applications.** For example: Do not grind with the side of a cut-off wheel. Abrasive cut-off wheels are intended for peripheral grinding; side forces applied to these wheels may cause them to shatter.
- d) **Always use undamaged wheel flanges that are of correct size and shape for your selected wheel.** Proper wheel flanges support the wheel thus reducing the possibility of wheel breakage. Flanges for cut-off wheels may be different from grinding wheel flanges.
- e) **Do not use worn down wheels from larger power tools.** A wheel intended for a larger power tool is not suitable for the higher speed of a smaller tool and may burst.
- 4) ADDITIONAL SAFETY WARNINGS SPECIFIC FOR CUTTING OFF OPERATIONS**
- a) **Do not "jam" the cut-off wheel or apply excessive pressure. Do not attempt to make an excessive depth of cut.** Overstressing the wheel increases the loading and susceptibility to twisting or binding of the wheel in the cut and the possibility of kickback or wheel breakage.
- b) **Do not position your body in line with and behind the rotating wheel.** When the wheel, at the point of operation, is moving away from your body, the possible kickback may propel the spinning wheel and the power tool directly at you.
- c) **When the wheel is binding or when interrupting a cut for any reason, switch off the power tool and hold the power tool motionless until the wheel comes to a complete stop. Never attempt to remove the cut-off wheel from the cut while the wheel is in motion, otherwise kickback may occur.** Investigate and take corrective action to eliminate the cause of wheel binding.
- d) **Do not restart the cutting operation in the workpiece. Let the wheel reach full speed and carefully re-enter the cut.** The wheel may bind, walk up or kickback if the power tool is restarted in the workpiece.
- e) **Support panels or any oversized workpiece to minimize the risk of wheel pinching and kickback.**

Large workpieces tend to sag under their own weight. Supports must be placed under the workpiece near the line of cut and near the edge of the workpiece on both sides of the wheel.

- f) **Use extra caution when making a "pocket cut" into existing walls or other blind areas.** The protruding wheel may cut gas or water pipes, electrical wiring or objects that can cause kickback.

### **5) SAFETY WARNINGS SPECIFIC FOR SANDING OPERATIONS**

- a) **When sanding, do not use excessively oversized sanding disc paper. Follow the manufacturers' recommendations when selecting sanding paper.** Larger sanding paper extending beyond the sanding pad presents a laceration hazard and may cause snagging, tearing of the disc, or kickback.

### **6) SAFETY WARNINGS SPECIFIC FOR WIRE BRUSHING OPERATIONS**

- a) **Be aware that wire bristles are thrown by the brush even during ordinary operation. Do not overstress the wires by applying excessive load to the brush.** The wire bristles can easily penetrate light clothing and/or skin.
- b) **If the use of a guard is recommended for wire brushing, do not allow any interference of the wire wheel or brush with the guard.** Wire wheel or brush may expand in diameter due to work load and centrifugal forces.

### **GENERAL**

- Only use the flanges which are supplied with this tool
- This tool should not be used by people under the age of 16 years
- This tool is not suitable for wet grinding/cutting
- **Always disconnect plug from power source before making any adjustment or changing any accessory**

### **ACCESSORIES**

- SKIL can assure flawless functioning of the tool only when original accessories are used
- **Use only grinding/cutting discs with a maximum thickness of 8 mm and a spindle hole diameter of 22 mm**
- For mounting/using non-SKIL accessories observe the instructions of the manufacturer concerned
- Never use reducers or adaptors to fit large-hole grinding/cutting discs
- Never use accessories with a "blind" threaded hole smaller than M14 x 21 mm

### **OUTDOOR USE**

- Connect the tool via a fault current (FI) circuit breaker with a triggering current of 30 mA maximum

### **BEFORE USE**

- Before using the tool for the first time, it is recommended to receive practical information
- Always check that the supply voltage is the same as the voltage indicated on the nameplate of the tool (tools with a rating of 230V or 240V can also be connected to a 220V supply)
- Always mount auxiliary handle E ② and protective guard F ②; never use the tool without them
- **Use suitable detectors to find hidden utility lines or call the local utility company for assistance** (contact with electric lines can lead to fire or electrical

shock; damaging a gas line can result in an explosion; penetrating a water pipe will cause property damage or an electrical shock)

- **Do not work materials containing asbestos** (asbestos is considered carcinogenic)
- Dust from material such as paint containing lead, some wood species, minerals and metal may be harmful (contact with or inhalation of the dust may cause allergic reactions and/or respiratory diseases to the operator or bystanders); **wear a dust mask and work with a dust extraction device when connectable**
- Certain kinds of dust are classified as carcinogenic (such as oak and beech dust) especially in conjunction with additives for wood conditioning; **wear a dust mask and work with a dust extraction device when connectable**
- Follow the dust-related national requirements for the materials you want to work with
- Be careful when cutting grooves, especially in supporting walls (slots in supporting walls are subject to country-specific regulations; these regulations are to be observed under all circumstances)
- **Secure the workpiece** (a workpiece clamped with clamping devices or in a vice is held more securely than by hand)
- Do not clamp the tool in a vice
- Use completely unrolled and safe extension cords with a capacity of 16 Amps (U.K. 13 Amps)

#### DURING USE

- Inrush currents cause short-time voltage drops; under unfavourable power supply conditions, other equipment may be affected (if the system impedance of the power supply is lower than 0,25 Ohm, disturbances are unlikely to occur); if you need further clarification, you may contact your local power supply authority
- If the cord is damaged or cut through while working, do not touch the cord, but immediately disconnect the plug
- Never use the tool when cord is damaged; have it replaced by a qualified person
- In case of electrical or mechanical malfunction, immediately switch off the tool and disconnect the plug
- In case of current interruption or when the plug is accidentally pulled out, unlock the on/off switch H ② immediately in order to prevent uncontrolled restarting

#### AFTER USE

- After switching off the tool, never stop the rotation of the accessory by a lateral force applied against it

#### WHEN CONNECTING NEW 3-PIN PLUG (U.K. ONLY):

- Do not connect the blue (= neutral) or brown (= live) wire in the cord of this tool to the earth terminal of the plug
- If for any reason the old plug is cut off the cord of this tool, it must be disposed of safely and not left unattended

## USE

- Mounting of accessories ②
  - ! **disconnect the plug**
  - clean spindle A and all parts to be mounted
  - tighten clamping flange B with spanner C while pushing spindle-lock button D
  - ! **push spindle-lock button D only when spindle A is at a standstill**
  - for removing accessories handle vice-versa

! **grinding/cutting discs become very hot during use; do not touch them until they have cooled down**

! **always mount backing pad when using sanding accessories**

! **never use a grinding/cutting disc without the label ("blotter") which is glued onto it (if provided)**

- Mounting of auxiliary handle E ⑤
  - ! **disconnect the plug**
  - screw auxiliary handle E on the right, the top, or the left of the tool (depending on the work to be carried out)
- Removing/mounting/adjusting of protective guard F ⑥
  - ! **disconnect the plug**
  - ! **ensure that the closed side of the protective guard always points to the operator**
  - if necessary, adjust protective guard F by tightening screw X which is pre-set at manufacturing (**ensure that the protective guard is closed**)
- Before using the tool
  - ensure that accessory is correctly mounted and firmly tightened
  - check if accessory runs freely by turning it by hand
  - test-run tool for at least 30 seconds at highest no-load speed in a safe position
  - stop immediately in case of considerable vibration or other defects and check tool to determine the cause
- On/off locking switch H ⑦
  - switch on tool ⑦a
  - ! **be aware of the sudden impact when the tool is switched on**
  - ! **before the accessory reaches the workpiece, the tool should run at full speed**
  - lock switch ⑦b
  - unlock switch/switch off tool ⑦c
  - ! **before switching off the tool, you should lift it from the workpiece**
  - ! **the accessory continues to rotate for a short time after the tool has been switched off**
- Grinding ⑧
  - move the tool back and forth with moderate pressure
  - ! **never use a cutting disc for side grinding**
- Cutting ⑨
  - do not tilt the tool while cutting
  - always move the tool in same direction as arrow on tool head, in order to prevent the tool from being pushed out of the cut in an uncontrolled manner
  - do not apply pressure on the tool; let the speed of the cutting disc do the work
  - the working speed of the cutting disc depends on the material to be cut
  - do not brake cutting discs with side pressure
- Holding and guiding the tool
  - always hold the tool firmly with both hands, so you will have full control of the tool at all times
  - ! **while working, always hold the tool at the grey-coloured grip area(s) ⑩**
  - provide for a secure stance
  - pay attention to the direction of rotation; always hold the tool so, that sparks and grinding/cutting dust fly away from the body
  - keep ventilation slots J ② uncovered



## MAINTENANCE / SERVICE

- Always keep tool and cord clean (especially ventilation slots J ②)  
**! do not attempt to clean ventilation slots by inserting pointed objects through openings ! disconnect the plug before cleaning**
- If the tool should fail despite the care taken in manufacturing and testing procedures, repair should be carried out by an after-sales service centre for SKIL power tools
  - send the tool **undismantled** together with proof of purchase to your dealer or the nearest SKIL service station (addresses as well as the service diagram of the tool are listed on [www.skilmasters.com](http://www.skilmasters.com))

## ENVIRONMENT

- **Do not dispose of electric tools, accessories and packaging together with household waste material** (only for EU countries)
  - in observance of European Directive 2002/96/EC on waste of electric and electronic equipment and its implementation in accordance with national law, electric tools that have reached the end of their life must be collected separately and returned to an environmentally compatible recycling facility
  - symbol ① will remind you of this when the need for disposing occurs

## CE DECLARATION OF CONFORMITY

- We declare under our sole responsibility that this product is in conformity with the following standards or standardized documents: EN 60745, EN 61000, EN 55014, in accordance with the provisions of the directives 2004/108/EC, 2006/42/EC, 2011/65/EU
- **Technical file at:** SKIL Europe BV (PT-SEU/ENG1), 4825 BD Breda, NL

Marijn van der Hoofden  
Operations & Engineering

Olaf Dijkgraaf  
Approval Manager

SKIL Europe BV, 4825 BD Breda, NL

31.01.2013

## NOISE/VIBRATION

- Measured in accordance with EN 60745 the sound pressure level of this tool is 91 dB(A) and the sound power level 102 dB(A) (standard deviation: 3 dB), and the vibration \* (hand-arm method; uncertainty K = 1.5 m/s<sup>2</sup>)
  - \* when surface grinding 7.3 m/s<sup>2</sup>
  - \* when sanding 3.5 m/s<sup>2</sup>**! other applications (such as cutting-off or wire brushing) may have different vibration values**
- The vibration emission level has been measured in accordance with a standardised test given in EN 60745; it may be used to compare one tool with another and as a preliminary assessment of exposure to vibration when using the tool for the applications mentioned

- using the tool for different applications, or with different or poorly maintained accessories, may significantly **increase** the exposure level
- the times when the tool is switched off or when it is running but not actually doing the job, may significantly **reduce** the exposure level
- ! protect yourself against the effects of vibration by maintaining the tool and its accessories, keeping your hands warm, and organizing your work patterns**

F

## Meuleuse d'angle

9425

## INTRODUCTION

- Cet outil sert au meulage, au tronçonnage et à l'ébarbage de pièces en métal et en pierre sans utiliser de l'eau; combiné avec des accessoires spécifiques, cet outil peut également servir au brossage et au ponçage
- **Les opérations de coupe avec disques à tronçonner abrasifs ne sont autorisées que si une protection de tronçonnage (disponible en option comme accessoire SKIL 2610Z00995) est utilisée**
- Lisez et conservez ce manuel d'instruction ③

## SPECIFICATIONS TECHNIQUES ①

## ELEMENTS DE L'OUTIL ②

- A Arbre
- B Bride de serrage
- C Clé
- D Bouton de blocage de l'arbre
- E Poignée auxiliaire
- F Protège-main
- G Bride de montage
- H Interrupteur marche/arrêt de verrouillage
- J Fentes de ventilation

## SECURITE

### INSTRUCTIONS GENERALES DE SECURITE

**ATTENTION!** Lisez tous les avertissements de sécurité et toutes les instructions. Ne pas suivre les avertissements et instructions peut entraîner un choc électrique, un incendie et/ou de graves blessures sur les personnes. **Conservez tous les avertissements et toutes les instructions pour pouvoir s'y reporter ultérieurement.** La notion d'"outil électroportatif" dans les avertissements se rapporte à des outils électriques raccordés au secteur (avec câble de raccordement) et à des outils électriques à batterie (sans câble de raccordement).

#### 1) SECURITE DE LA ZONE DE TRAVAIL

- a) **Maintenez l'endroit de travail propre et bien éclairé.**  
Un lieu de travail en désordre ou mal éclairé augmente le risque d'accidents.
- b) **N'utilisez pas l'appareil dans un environnement présentant des risques d'explosion et où se trouvent**