

Thank you for purchasing a Sealey product. Manufactured to a high standard this product will, if used according to these instructions and properly maintained, give you years of trouble free performance.



**IMPORTANT: PLEASE READ THESE INSTRUCTIONS CAREFULLY. NOTE THE SAFE OPERATIONAL REQUIREMENTS, WARNINGS AND CAUTIONS. ALSO CONSULT YOUR VEHICLE MANUFACTURER'S HANDBOOK AND TAKE NOTE OF ANY SPECIAL INSTRUCTIONS RELATING TO TOWING. USE THIS PRODUCT CORRECTLY AND WITH CARE FOR THE PURPOSE FOR WHICH IT IS INTENDED. FAILURE TO DO SO MAY CAUSE DAMAGE OR PERSONAL INJURY AND WILL INVALIDATE THE WARRANTY. PLEASE KEEP INSTRUCTIONS SAFE FOR FUTURE USE.**

### 1. SAFETY INSTRUCTIONS

- ✓ This trailer/cart is designed for use on private land only.
- ✓ Maximum towing speed must not exceed 10mph.
- ✗ DO NOT tow this trailer/cart on public roads or thoroughfares.
- ✗ DO NOT allow passengers to travel in the trailer.
- ✓ It is important that your trailer/cart is serviced on a regular basis to ensure your own safety and that of others in the area of use.
- ✓ Maintain the trailer/cart in good condition. Replace or repair damaged parts. Use recommended parts only. Unauthorised parts may be dangerous and will invalidate the warranty.
- ✓ Ensure that the towing vehicle has a correctly and solidly mounted towing bracket.
- ✓ The towing bracket must be strong enough to tow a fully laden trailer. Check that there is no corrosion in the area of the mountings.
- ✓ It is your responsibility to ensure that the towing vehicle is adequate to tow the trailer and its load. Check that the brakes are powerful enough. Check that the gross weight of the trailer does not exceed the towing capacity of the vehicle. The vehicle's recommended towing limit should be in the vehicle manufacturer's handbook.
- ✓ The addition of a loaded trailer to a vehicle will have a very serious effect on the vehicles performance. Starting, particularly on hills, can be much more laboured; stopping can take longer distances; cornering and negotiating sharp bends require extra care. If you have no experience of towing a trailer you should practice in a quiet area. Particular attention should be paid to reversing a trailer/cart.
- ✓ Certain loads may require to be securely tied down or restrained.
- ✓ There must be no load projections outside the trailer/cart that might cause danger to others in the area.
- ✓ Loads must be evenly distributed within the trailer/cart and positioned in such a way as to keep the trailer/cart level.
- ✓ The nose weight is an important factor in keeping the vehicle/trailer combination stable during towing. If the load is too far back, inadequate nose weight will result in snaking problems. If the load is too far forward, resulting in excessive nose weight, the rear of the vehicle may be forced down resulting in a detrimental effect on the steering.
- ✓ Always ensure that the tyre pressures are correct and that the tyres are free from cuts and bulges and have adequate tread.
- ✓ Always ensure that the trailer is correctly connected to the towing bracket before setting off.
- ✓ Before setting off ensure that the towing hitch is correctly folded out and locked in position.

### 2 SPECIFICATION

#### Specification:

1 Model No: .....	TBB300
2 Capacity: .....	300kg
3 Tyre Size: .....	Ø380 x 90mm
4 Trailer Bed Size, .....	Internal
5 Length .....	1050mm
6 Width: .....	760mm
7 Depth: .....	280mm
8 Overall Height: .....	790mm

### 3. INTRODUCTION

Rustproof polypropylene trailer bed with heavy-duty steel frame. Fitted with pneumatic tyres for transport over the toughest terrain and single locking castor wheel. Features foot pedal release mechanism for tipping trailer bed. Easily and quickly converts into hand cart with foldaway towing hitch and sliding hand rail.

### 4 . ASSEMBLY

- 4.1** Unpack all components including the hardware pack and check the contents against the parts list at the end of this document. If any parts are damaged or missing contact your Sealey dealer.
- 4.1.1** Insert the foot pedal through the rear tongue as shown in fig.1 and create the pivot using an M6x90 hex bolt, an M6 lock nut and two spacers. On the underside of the rear tongue, hook the spring through hole 'X' in the pedal and the other end through hole 'Y' in the tongue.

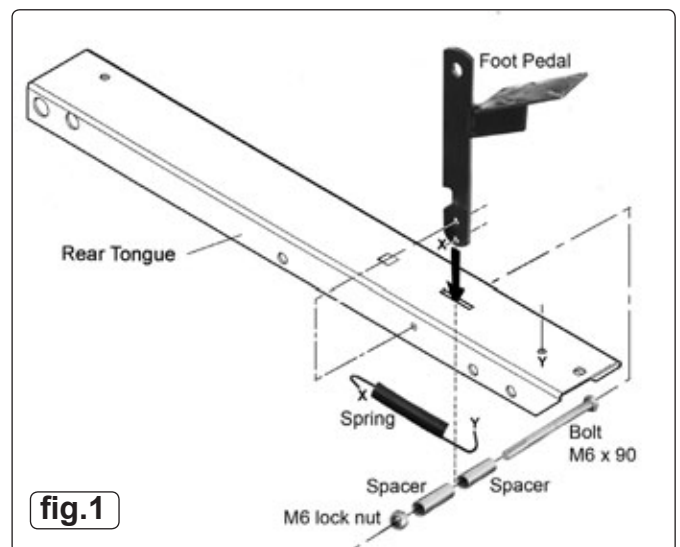

- 4.1.2** Fig.2 shows the rear tongue inverted with the foot pedal fully assembled, with the spring in place.



4.1.3 Lay the rear tongue (open side facing up) onto the Wheel Support. Assemble the axle through the wheel support and the tongue as indicated in fig.3.

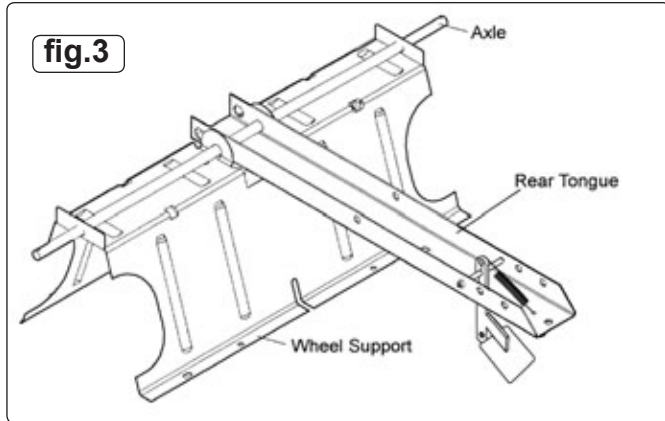

4.3 Assemble a wheel to each end of the axle (with the valve stem facing outwards). Ensure that a washer is placed either side of each wheel. Retain the wheels with a Ø3x25 cotter pin through each end of the axle.

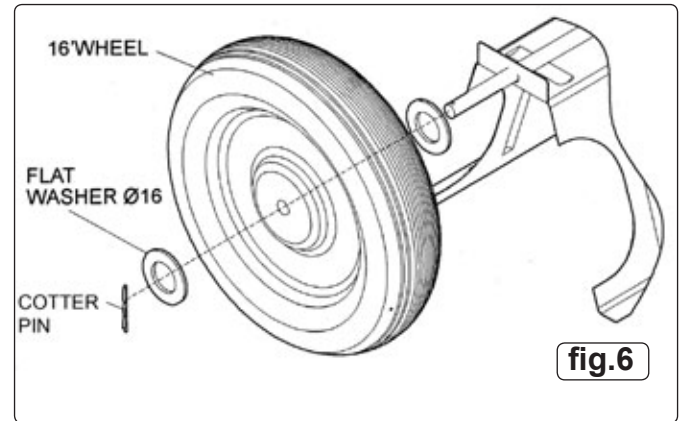

4.2 Assemble the hitch bracket to the front tongue using two sets of M8x20mm hex bolts with M8 lock nuts as shown in fig.4.

4.2.1 Assemble the 4" swivel caster to the front tongue using 4 M6x16 hex bolts and M8 lock nuts. See fig.4. Tighten fixings.

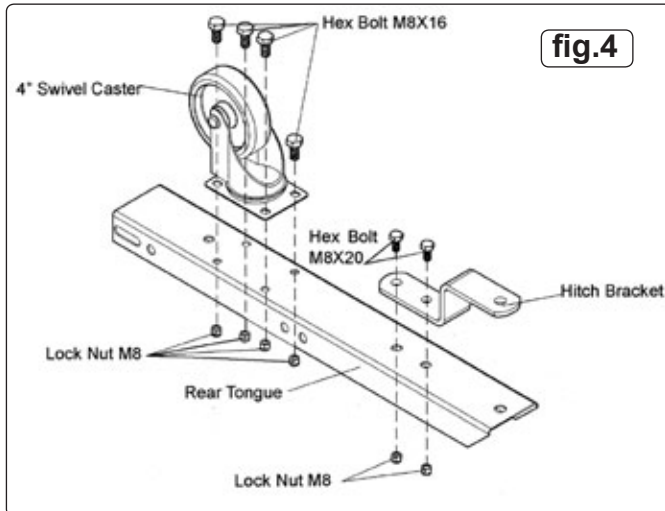

4.3.1 Turn the wheel support over to rest on the wheels. Place the latch stand bracket onto the tongue sliding it underneath the foot pedal notch. Orientate the latch stand plate as shown in fig.7. The tabs at the end of the channels must face to the rear. Place the latch stand plate down onto the latch stand bracket as shown in fig.7.

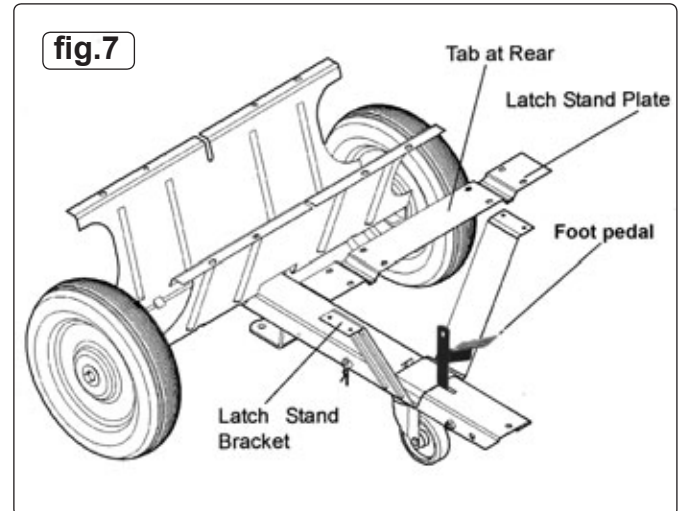

4.2.2 Place the front tongue inside the rear tongue as shown in fig.5. Fasten the tongues together using an M10x95 bolt and a 10mm lock nut. Do not overtighten the nut as this bolt acts as a pivot between the front and rear tongue.

4.2.3 Insert a clevis pin Ø13x98 through both tongues and secure with an 'R' pin Ø3 as shown in fig.5.

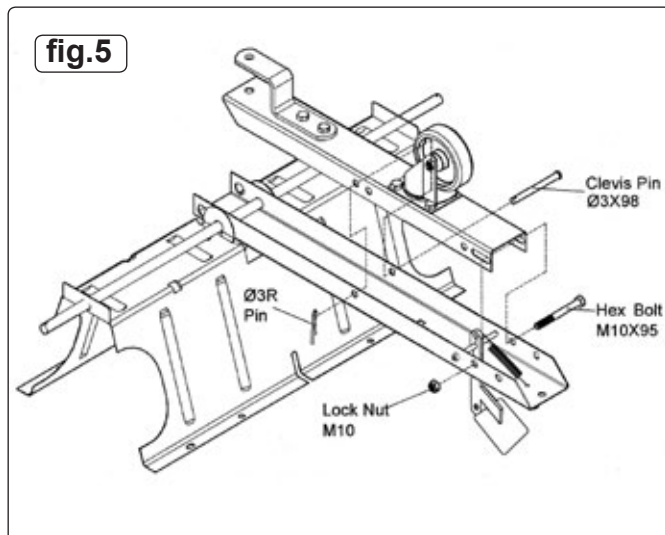

4.3.2 Place the poly tray down onto the wheel support and the latch stand plate. Fasten the tray to the wheel support using eight M8x16 flat head bolts and M8 lock nuts. Fasten the tray to the latch stand plate and latch stand bracket using four M6x16 flat head bolts and M6 lock nuts as shown in fig.8. Do not fully tighten yet.

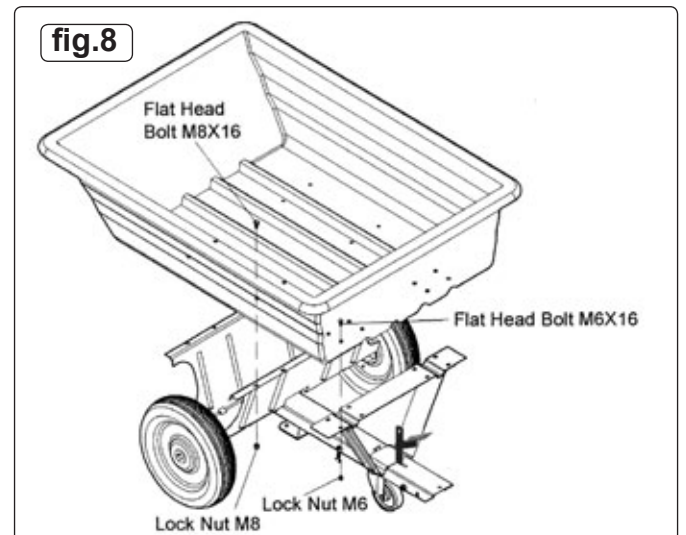

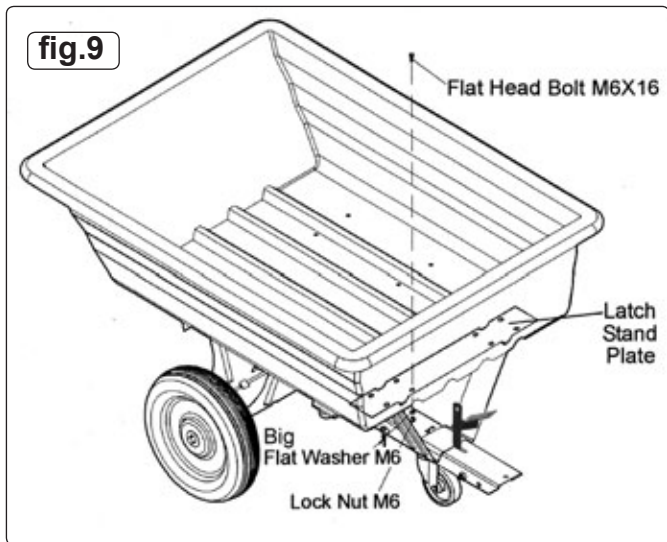

- 4.3.3 Insert four M6x16 flat headed bolts down through the tray and the inside holes in the latch stand plate. Secure the bolts with four Ø6 flat washers and M6 nuts as shown in fig.9 but do not yet fully tighten.
- 4.3.4 When all tray fixings are in place, fully tighten them.

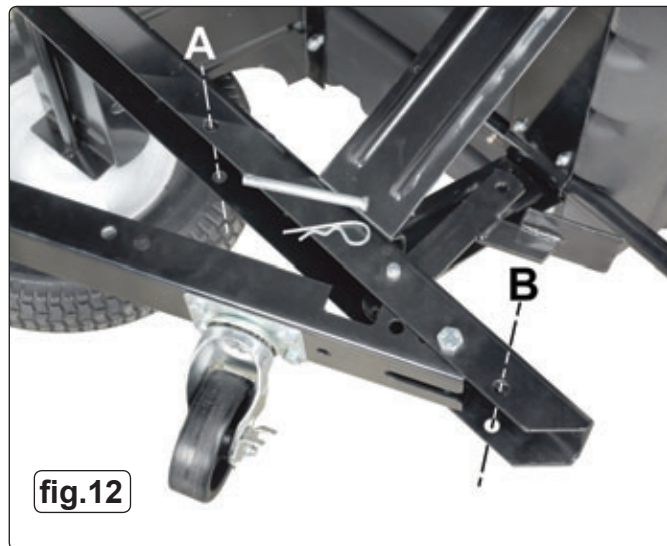

- 4.4.2 To convert the handcart as seen in fig.11 to a trailer as seen in fig.13, tip the cart back to rest on the back edge of the tray to gain access to the front and back tongues. Remove the 'R' clip from the clevis pin at position 'A' and withdraw it. See fig.12. Allow the front tongue to hinge away from the back tongue and move it through 180° until it is pointing forwards as seen in fig.13. Align the holes in the two tongue components and insert the clevis pin at position 'B'. Retain the Clevis pin by inserting the 'R' pin through the hole in the end of it.

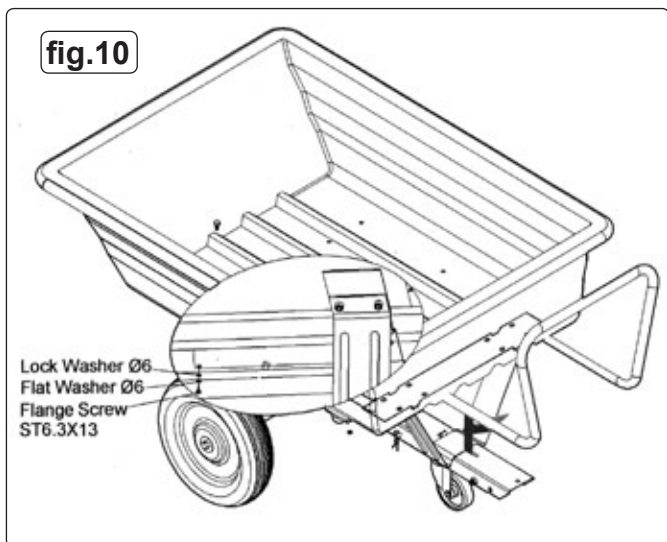

- 4.4 Slide the handle into the channels in the latch stand plate. Push the handle in all the way against the front of the tray by depressing the detent buttons in the bottom of the handle as shown in fig.10.
- 4.4.1 Assemble an Ø6 lock washer and then Ø6 flat washer onto each of the two Self Tapping 6.3x13 flange screws. Screw a screw into the hole at each end of the handle as shown in fig.10



- 4.4.3 Assemble the hitch pin through the tongue and hitch bracket and secure it with a Ø3 'R' pin. See fig.14

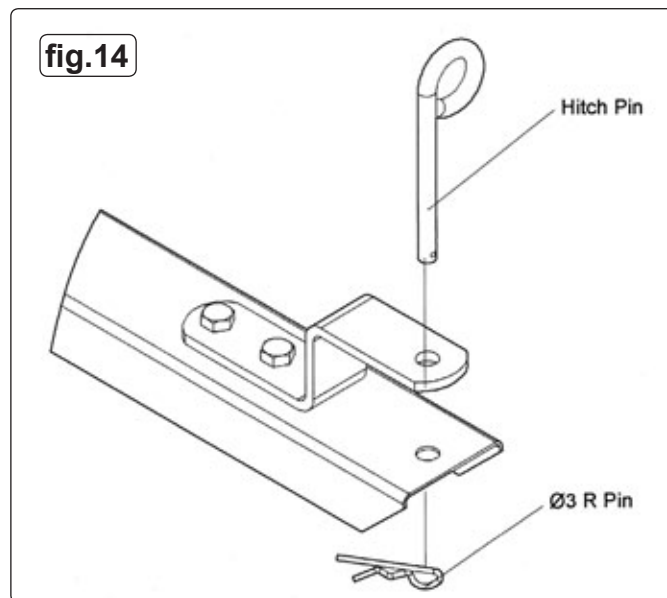



## 5. OPERATION

- ❑ **WARNING!** Read the safety instructions at the start of this document before using this product.
- 5.1 Use as a trailer.** If the cart is still in the manual configuration, refer to 4.4.2 and 4.4.3 for information on converting it to the towable configuration. See figs.12 & 13 & 14.
  - 5.1.1 NOTE: The maximum towing speed for this product is 10mph.
  - 5.1.2 Do not exceed the 300kg weight capacity of the cart. (One cubic foot of dirt weighs approximately 68kg).
  - 5.1.3 It is your responsibility to ensure that the towing vehicle is adequate to tow the trailer and its load. Check that the brakes are powerful enough. Check that the gross weight of the trailer does not exceed the towing capacity of the vehicle. The vehicle's recommended towing limit should be in the vehicle manufacturer's handbook.
  - 5.1.4 Use extreme caution when operating the vehicle and trailer on sloping land especially when the cart is filled to capacity. If in doubt about stability in any situation, do not proceed.
  - 5.1.5 For best handling and traction always ensure that the load is evenly distributed in the cart.
  - 5.1.6 To dump material from the cart firstly ensure that the cart is in the right position and that no one is in the dumping area. To tip the load, press the foot pedal. Gravity will ensure that a full load is swiftly shed and therefore no parts of your body should be in the way of the moving hopper.
  - 5.1.7 Once the load is shed, take hold of the upper edge of the hopper and pull it back down onto the cart chassis until it latches back into the notch in the foot pedal lever.
- ❑ **WARNING!** Read the safety instructions at the start of this document before using this product.
- 5.2 Use as a hand cart.** If the cart is still in the towing configuration, reverse the process described in section 4.4.2 so that the towing hitch is folded back underneath the tray as shown in figs.11 and 12. Ensure that the clevis pin and 'R' pin are correctly installed as shown in fig.5 so that the assembly is safely locked.
  - 5.2.1 Do not exceed the 300kg weight capacity of the cart. (One cubic foot of dirt weighs approximately 68kg).
  - 5.2.2 Do not overfill the hopper or load it unevenly as this will make the cart difficult to manoeuvre. Remember that the cart is now operating on 3 wheels.
  - 5.2.3 Use extreme caution when moving the cart on sloping land, especially when the cart is filled to capacity. If in doubt about stability in any situation, do not proceed.
  - 5.2.4 To dump material from the cart firstly ensure that the cart is in the right position and that no one is in the dumping area. To tip the load, press the foot pedal. Gravity will ensure that a full load is swiftly shed and therefore no parts of your body should be in the way of the moving hopper.
  - 5.2.5 Once the load is shed, take hold of the upper edge of the hopper and pull it back down onto the cart chassis until it latches back into the notch in the foot pedal lever.



**NOTE:** It is our policy to continually improve products and as such we reserve the right to alter data, specifications and component parts without prior notice.

**IMPORTANT:** No liability is accepted for incorrect use of this product.

**WARRANTY:** Guarantee is 12 months from purchase date, proof of which will be required for any claim.

**INFORMATION:** For a copy of our latest catalogue and promotions call us on 01284 757525 and leave your full name and address, including postcode.



Sole UK Distributor, Sealey Group,  
Kempson Way, Suffolk Business Park,  
Bury St. Edmunds, Suffolk,  
IP32 7AR



01284 757500



www.sealey.co.uk



01284 703534



sales@sealey.co.uk