

# CRAFTSMAN ROUTER TABLE MK2

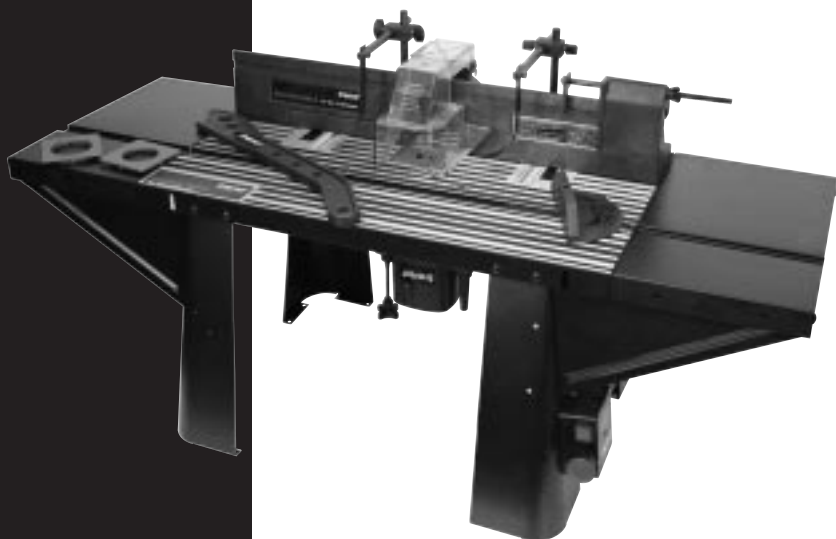

***trend***<sup>®</sup>  
routing technology

ITEMS ENCLOSED

- 1 x Table top
- 4 x Legs
- 1 x Back fence and fittings
- 1 x Workpiece Support and fittings
- 1 x Tenon Block and fittings
- 1 x Top guard and fittings
- 1 x Mitre fence
- 1 x No-Volt Release Switch
- 3 x Insert rings
- 2 x Table extensions
- 1 x Lead-on Pin
- 1 x Spanner (9.5mm A/F)
- 1 x Screw and Fittings Pack
- 1 x Pushstick
- 1 x Instructions
- 1 x Guarantee card

DESCRIPTION OF PARTS

- ① Legs
- ② Fixing plate
- ③ Table top
- ④ Back fence
- ⑤ Workpiece support
- ⑥ Guard
- ⑦ Tenon push block
- ⑧ Lead-on pin
- ⑨ Mitre fence
- ⑩ Switch
- ⑪ Pushstick
- ⑫ Table extensions
- ⑬ Insert rings

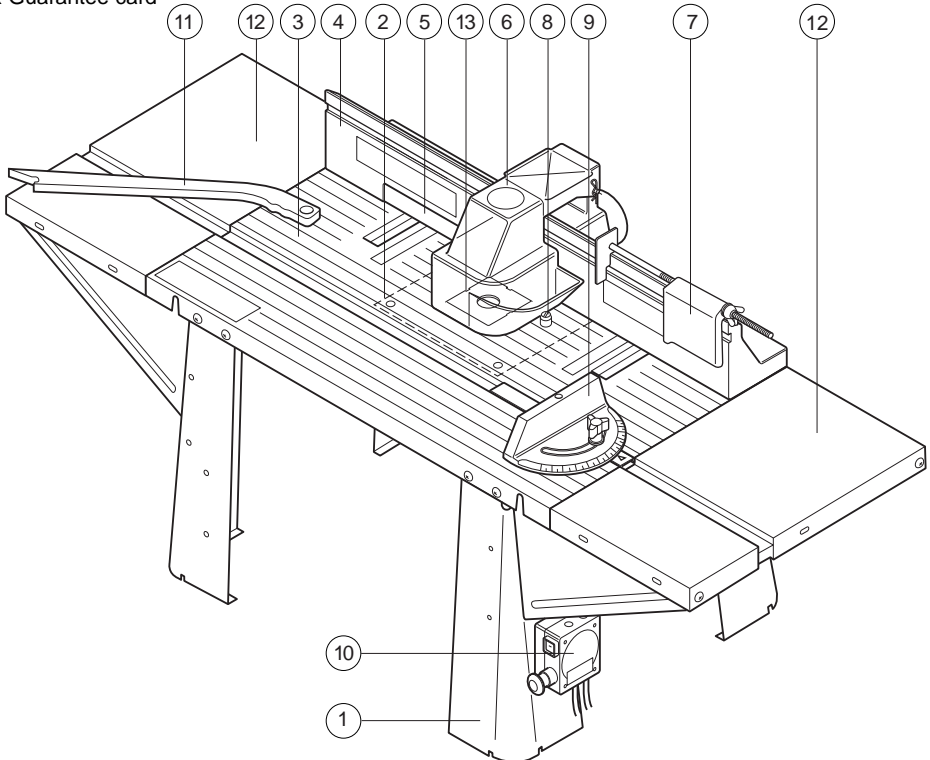

## SAFETY PRECAUTIONS

- Always switch off the power and unplug the router when changing cutters or when making adjustments.
- Always wear protective goggles when routing.
- Wear sound protective ear muffs when routing for long periods of time.
- Always wear a dust mask. Use dust extraction equipment whenever possible.
- Do not wear loose clothing. Make sure baggy sleeves are rolled up and ties are removed.
- Always remove spanners and hex keys from the workpiece before switching router on.
- Keep hands well clear of the router cutter when routing.
- Avoid accidental starting of the router. Make sure the power switch is in the 'Off' position before plugging in and connecting to the electrical supply.
- Never leave the router unattended when running. Always wait until the router comes to a complete stop before making adjustments.
- Do not switch the router on with the cutter touching the workpiece.
- Mount the router table securely to a work bench.
- Periodically check all nuts and bolts to make sure they are tight and secure.

## Cutter Care

- Do not drop cutters or knock them against hard objects.
- Cutters should be kept clean. Resin build-up should be removed at regular intervals with Resin Cleaner<sup>®</sup>. The use of a dry lubricant will act as a preventative such as Trendicote<sup>®</sup> PTFE spray. Do not use PTFE spray on plastic components.
- Cutter shanks should be inserted into the collet at least 3/4 of shank length to prevent distortion. A distorted collet should be discarded, as it can cause vibration and damage the shank.

- Do not over-tighten collet as this will score the shank and create a weakness there.
- It is also advisable to periodically check the router collet nut for wear.

## Useful Advice

- Judge your feed rate by the sound of the motor. In time, the operator will acquire a 'feel' for the router, and a feed speed relative to the work will come naturally. Too slow a feed will result in burning.
- Apply the normal precautions as with any electric power tool.
- The main abuse of routing machines is the inclination for operators to overload them. The motto is 'Keep the revs up'. The drop in revolutions should not exceed, if possible, more than 20% of full running speed.
- The motor of a router is susceptible to the accumulation of sawdust and wood chips, and should be blown out, or 'vacuumed', frequently to prevent interference with normal motor ventilation.
- Refer to the Instruction Manual supplied with your router for full details of its features and safety information.
- Trial cuts should be made on waste material before starting any project.
- Do not store the router on the floor, as chippings, pins or dirt can drop into the air intake of the router.



### IMPORTANT:

To move table with leg stand fitted, please lift. Do not drag.

## ASSEMBLY

Assemble the parts as show in A to N.

For identification all fixings are illustrated as actual size.

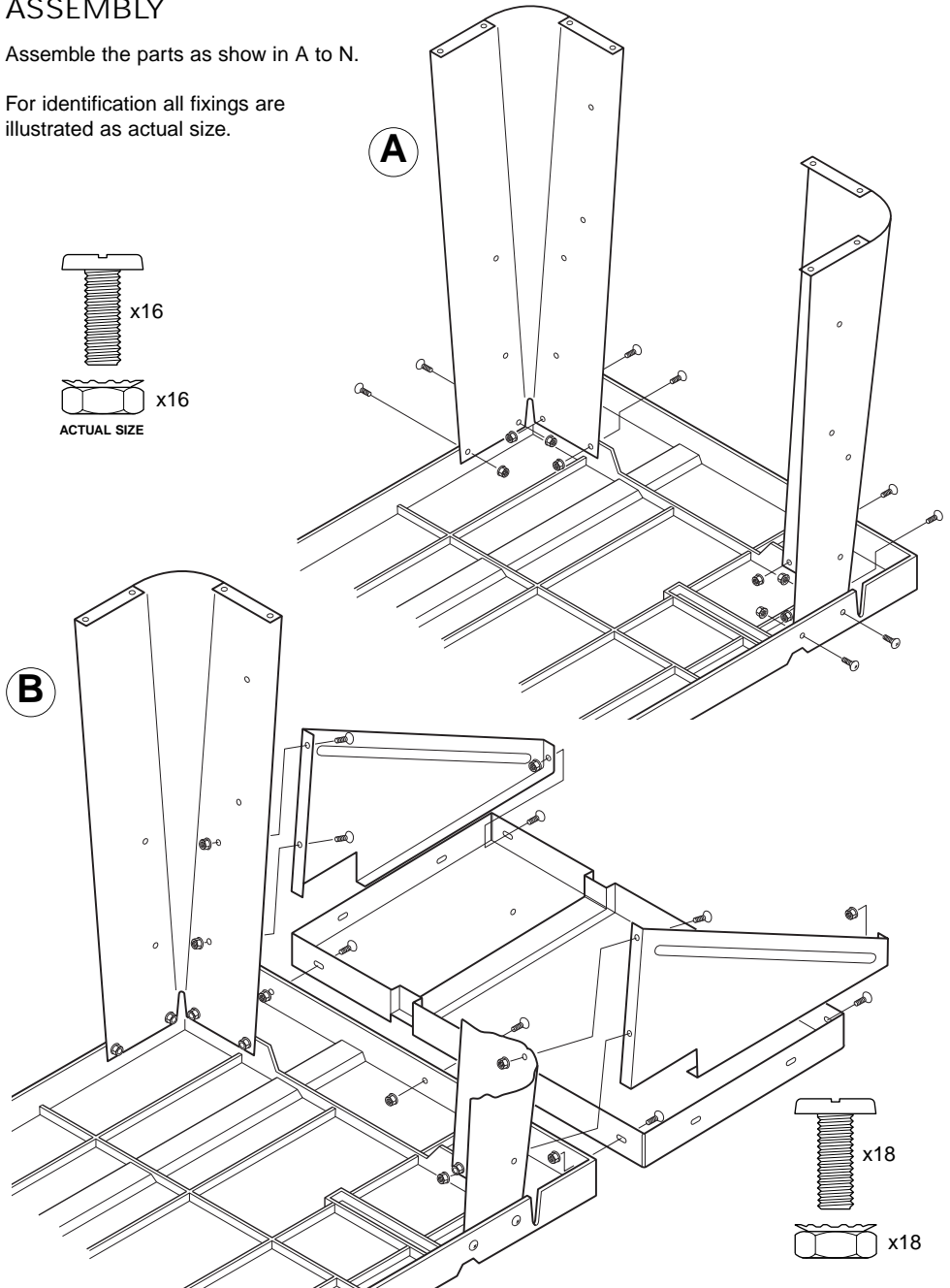

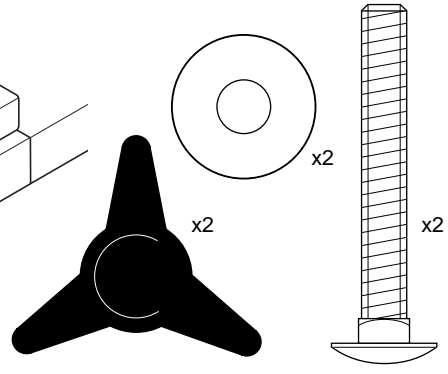
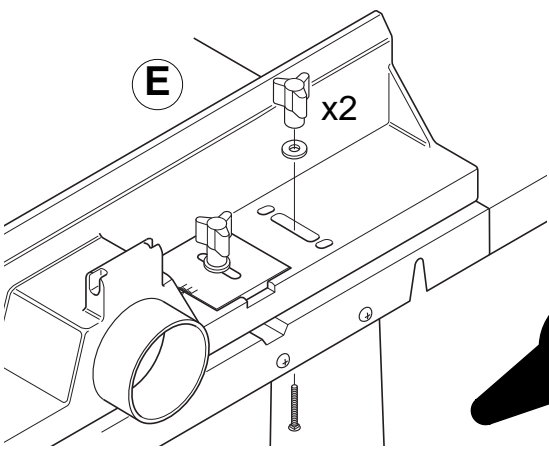
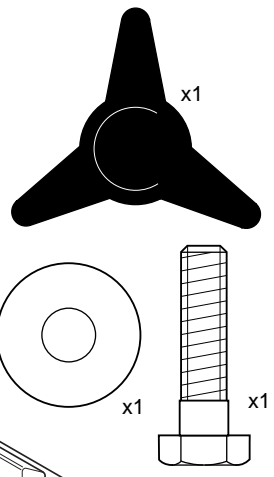
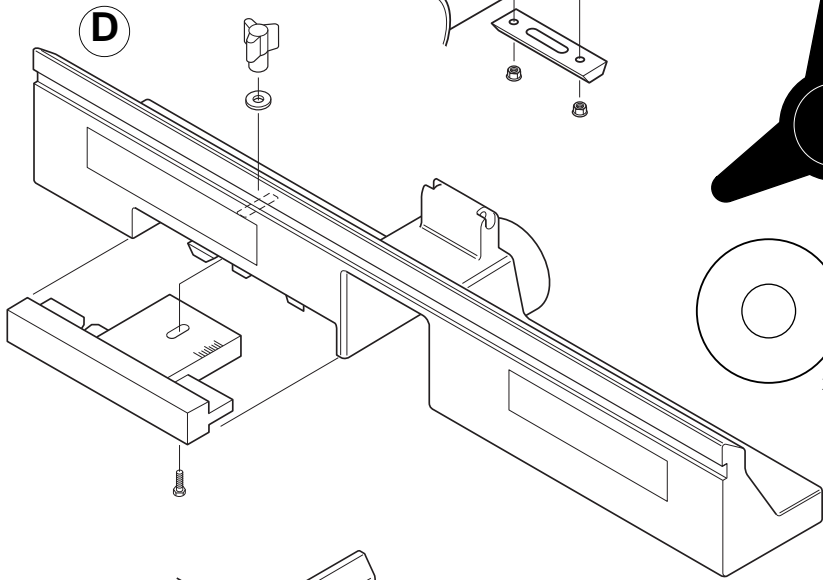
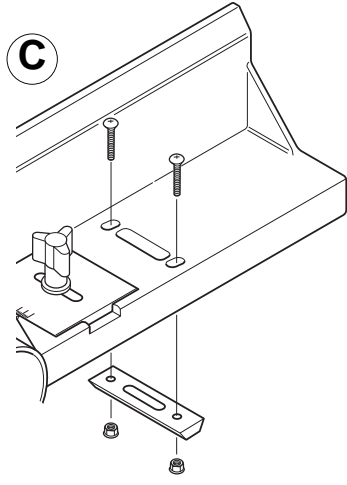
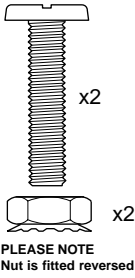

Identification of Router Mounting Holes and Screws (see pages 8 & 9).

- Identify the mounting holes and fixing screws (including washers & nuts if router base requires re-drilling) which will be required to suit your router.
- Identify whether your router or the fixing plate requires re-drilling.
- Bolt the router onto the fixing plate first with the operating controls to the front, before fitting to the table.
- The fixing plate is symmetrical therefore once the router is mounted to it, it can be fitted to the router table in four different positions. The orientation of the plate depends on which router is fitted. It is advisable to position the plate so that controls for speed or height are easily accessible.



**IMPORTANT!**

Some routers may require the removal of the plastic base slider to allow fitting to plate.

**Special note for Bosch POF routers**

For the Bosch POF range of DIY routers a packing piece must be made in 3mm to 6mm thick plywood or MDF. This is then placed between the underside of the plate in the table and the underside of the router base. The fixing screws can then be used. Enlarging the aperture in the base of the router is also advised if large diameter tooling is to be used.

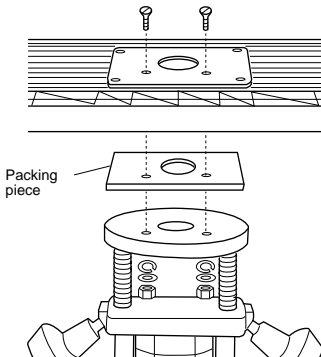

**IMPORTANT!**

Carry out the following re-drilling only if required.

**Re-drilling Router Base Only**

- Invert and stand your router onto a suitable surface.
- Place the fixing plate facing upwards onto the base of your router.
- Identify holes 1 and 2, or holes 3 on fixing plate (Ref. CRT/FP/A see page 8).
- Fit a large diameter cutter (max. 53mm Ø) into your router and tighten collet.
- Retract plunge mechanism and lock off allowing cutter to protrude through the base.
- Adjust position of the fixing plate to centralise the cutter within the centre hole. Take care not to damage cutter or to touch sharp edges.
- Ensure that the holes you are about to drill in the base do not interfere with any of the features on the router or any webbings in the casting of the router base. A slight turning of the plate may be required to miss such obstructions.
- Mark the centre of the holes onto the base.
- Remove plate and mark the centre of the holes with a centre punch.
- Drill a hole at these points with a 6mm diameter drill bit.
- Clean up edges of holes if required.

**Re-drilling Fixing Plate Only**

- Remove the plastic base of the router. Alternatively a photocopy or an outline of the base can be made of the plastic base instead.
- Draw cross lines onto the plastic base of the router.
- Draw cross lines on the fixing plate with a pencil. These cross lines should bisect the plate on both sides.

- Align the lines on the fixing plate with those on the plastic base and secure the fixing plate to the plastic base.

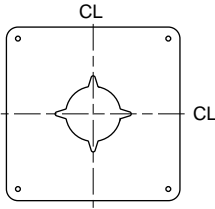

- Using a centre punch, mark the centres of holes.
- Drill the required hole size with a suitable metal cutting drill bit. Best results will be obtained if your power drill is mounted in a drill stand.
- Countersink the hole with a countersink bit to a depth so the heads of the screws are slightly below the top surface. Clean off any burrs created.



**IMPORTANT!**  
If you do not have the necessary equipment to carry out these operations, then a local engineering shop will be able to carry them out accurately for you.

#### Re-drilling both Fixing Plate and Router Base

- Invert the router and lay the fixing plate onto the upturned base.
- Clamp the fixing plate and router base together with two cramps.
- Ensuring that the drill bit will not foul any webbing or fixtures on the router base, drill with a 6mm diameter metal cutting drill bit into the fixing plate and through the router base two holes approximately 75mm apart.

- Unclamp the router base and fixing plate.
- Countersink the fixing plate holes with a countersink bit to a depth so the screw heads are slightly below the top surface. Clean off any burrs created on both the fixing plate and router base.

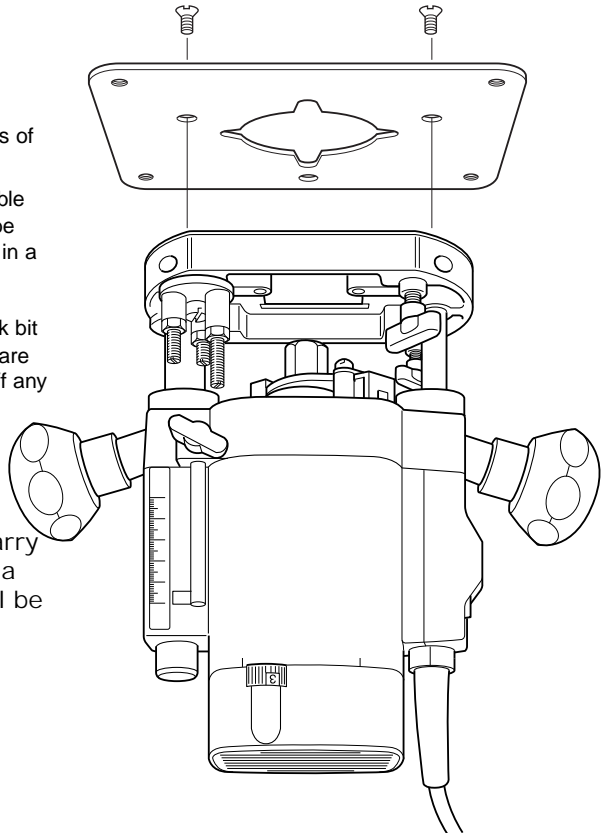

CRT/MK2  
FIXING  
PLATES

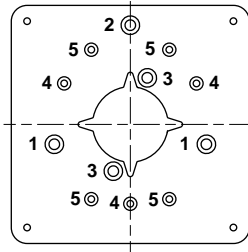

CRT/FP/A

TREND	T5	1	E x 2
TREND	T9	1 & 2	E x 3
AEG	OF4505, OF500S, OFE710	3 ●	G x 2
ATLAS COPCO	OFS720, OFSE850, OFS50 OFSE1000, OF500S	3 ●	G x 2
B&D	KW779, 780(E), 800(E) BD780(E)	4	A x 3
B&D	SR100, DN67, BD66	3 ●	G x 2
BOSCH	POF400,*500A*600ACE*	3	F x 2
BOSCH	GOF1600A, 1700ACE	1 & 2	F x 3
DEWALT	DW613	1	E x 2
DEWALT	DW620, 621	1	E x 2
DEWALT	DW625EK	1 & 2	F x 3
EINHELL	EOF850SP	3 ●	G x 2
ELU	MOF96(E) MK1	3 ●	G x 2
ELU	MOF96(E) MK2	1	E x 2
ELU	OF97(E)	1	E x 2
ELU	MOF131, 177(E)	1 & 2	F x 3
FELISATTI	R346EC	1 & 2	F x 3
FELISATTI	TP246(E)	■ ●	G x 2
FERM	FBF-6E, FBF-8E	3 ●	G x 2
FESTO	OF900(E), 1000(E), 1010EBC, 2000(E)	1 & 2 ●	H x 3
HITACHI	M8(V)	5	B x 4
HITACHI	FM8, ZK2008	3 ●	H x 2
HOLZHER	2335, 2355, 2356	■ ●	G x 2
KANGO	R8550S	3 ●	G x 2
KINZO	250C44	■	F x 2
KRESS	FM6955	3 ●	G x 2
LYNX	RT-800-A	3 ●	G x 2
MAFELL	LO50E, 65E	1 & 2 ●	H x 3
MAKITA	RP0910, 1110C	1	E x 2
METABO	OF528	3 ●	G x 2
METABO	OF1028, OFE1229	■ ●	G x 2
METABO	OF1612, OFE1812	■ ●	G x 2
NUTOOL	NPT850	3 ●	G x 2
PERLES	OF808(E) pre 1999	3 ●	G x 2
PERLES	OF808(E) post 1999	1	E x 2
PERFORMANCE POWER	1020W	3 ●	G x 2
POWER DEVIL	PDW5026	3 ●	G x 2
ORTER CABLE	100, 690, 693	3 ●	H x 2
POWER DEVIL	PDW5027	3 ●	G x 2
RYOBI	R500, R502	1 & 2 ●	H x 3
SPARKY	X52E	3 ●	G x 2
STAYER	PR50	3 ●	G x 2
VIRUTEX	FR77C, 78C, 66F	3 ●	H x 2
WADKIN	R500	1 & 2 ●	H x 3
WICKES	900W	3 ●	G x 2

CRT/FP/B

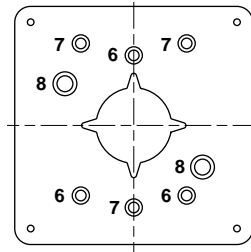

BOSCH	GOF900A, 900ACE, POF800ACE	6	H x 3
BOSCH	GOF1300ACE	7	H x 3
RYOBI	RE600N, R600N, RE601, R601	8	I x 2



**IMPORTANT!**  
Some routers may require the removal of their plastic base slider to allow fitting to the plate.

- Re-drilling of router base by user required
- Re-drilling of insert plate by user required
- \* Requires 3mm packing piece

CRT/FP/C

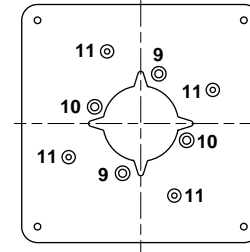

MAKITA	3620	10	D x 2
MAKITA	3612(C)	9	D x 2
		11	A x 4
MAKITA	3612BR	10	D x 2
		11	A x 4
MAKITA	3600B	■	D x 2
		■	A x 4

CRT/FP/D

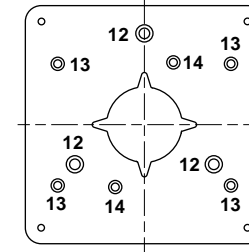

ATLAS COPCO	OFSE2000	12	F x 3
CASALS	FT750, 1000E, FT2000VCE	12	F x 3
DRAPER	R1900V	12	F x 3
FREUD	FT1000E, FT2000E	12	F x 3
HITACHI	M12SA, M12V	13	B x 4
HITACHI	TR12	■	B x 4
RYOBI	RE120, R150, R151, RE155K	14	D x 2
PEUGEOT	DF55E, DEF570E	14	B x 2
SKIL	1835, 1875U1	■	C x 3

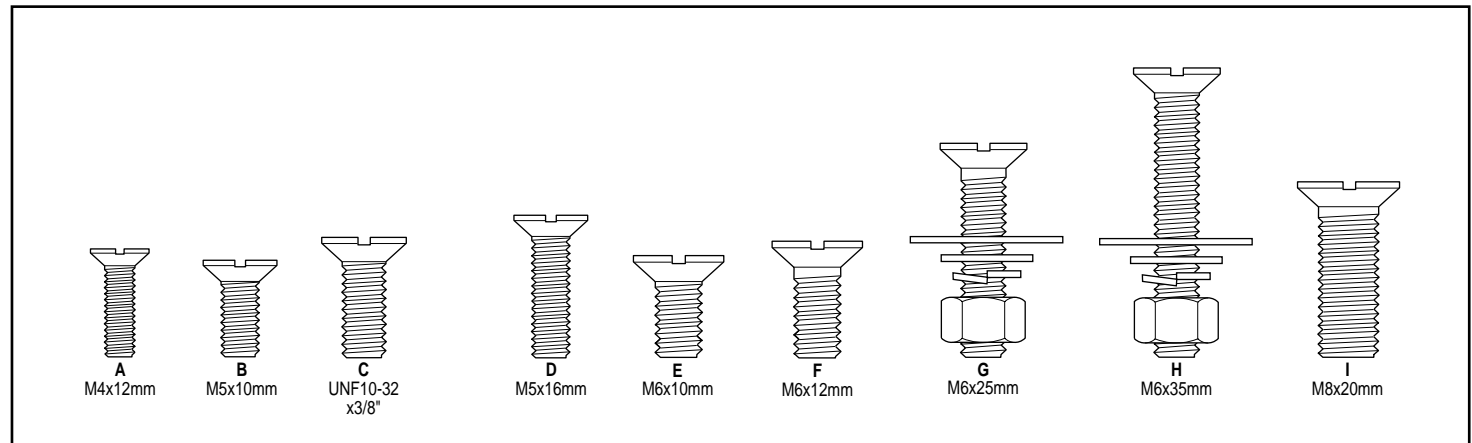

**F**

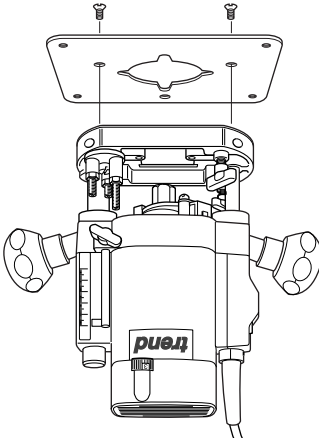

The fixing plate must be fitted to the router base before installation into the router table.

**G**

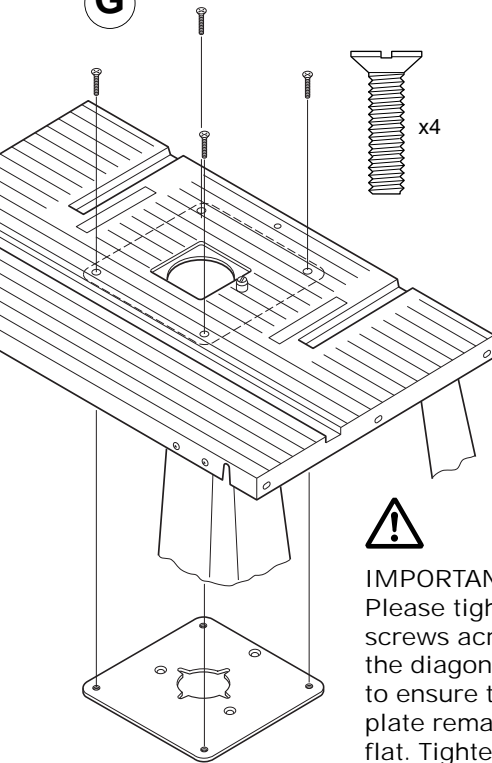

**IMPORTANT:**  
Please tighten screws across the diagonals, to ensure the plate remains flat. Tighten all screws evenly.

**H**

### Mounting Table to Workbench or Workboard

The router table must be mounted onto either the optional floor stand or onto a suitable workbench or workboard.

Each table leg has four holes at the bottom mounting. Firmly secure the table assembly to a workbench or workboard, using self-tapping screws (not provided).

If a workboard is used, this will allow quick mounting and removal from a workbench by using cramps. If a Workmate<sup>®</sup> is to be used then a batten can be fitted to allow securing in the Workmate's<sup>®</sup> jaws.

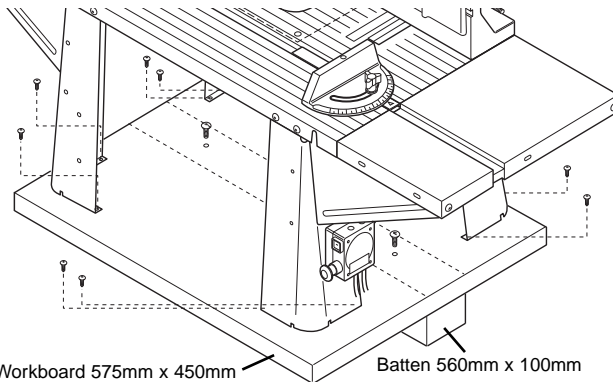

**I**

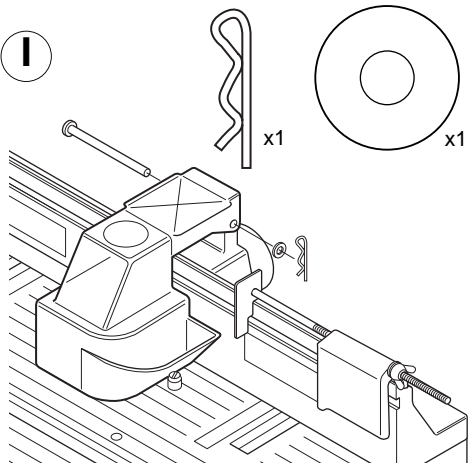

**J**

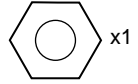
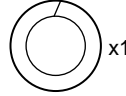
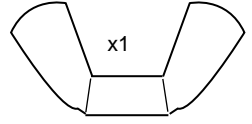
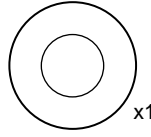
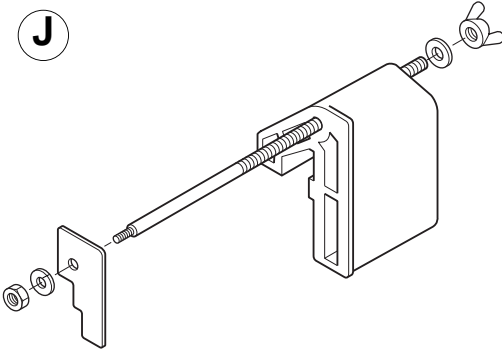

**K**

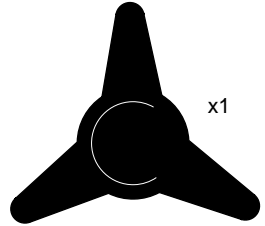
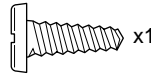
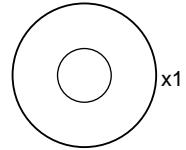
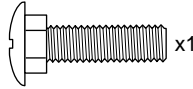
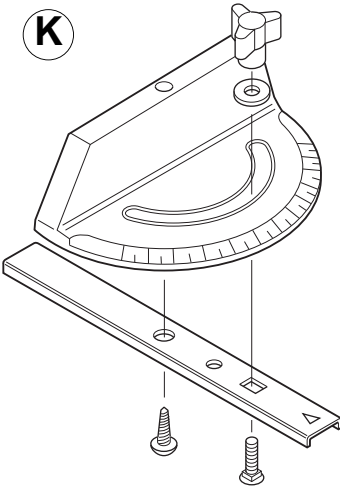

**L**

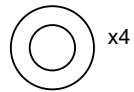
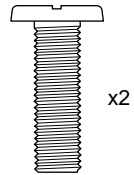
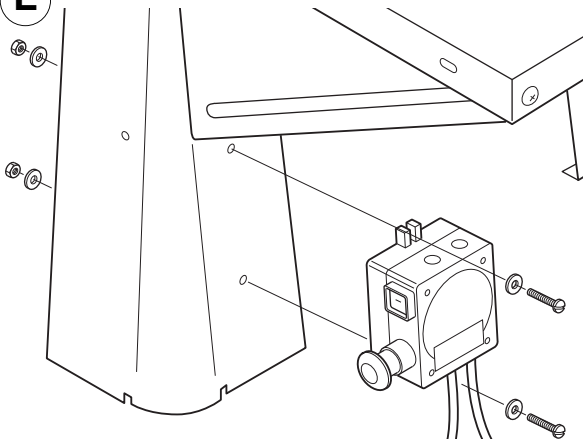

### Mounting the No-Volt Release Switch

- The no-volt release switch serves as start-up protection. When the router is plugged in and its on/off switch depressed, the router starts only after the green switch is pressed.
- Switch off the router using the red button.
- Attach the no-volt release switch to the table leg with the screws provided.
- Plug the router into the socket.



**IMPORTANT:**

Always remove the plug of the No-Volt Release Switch from the power source before making any adjustments.

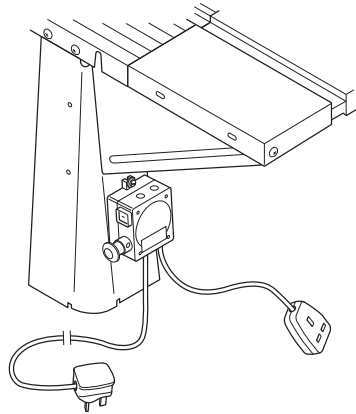

### Insert Rings

- For router cutter diameters up to 50mm, insert rings can be fitted. They serve to keep the opening between the tool and the routing table as small as possible.
- The diameter of the insert ring should be approximately 4mm larger than the cutter diameter.

Max. router cutter size without insert rings:  
- 53mm Ø max

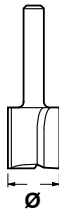

Max. router cutter sizes with insert rings:

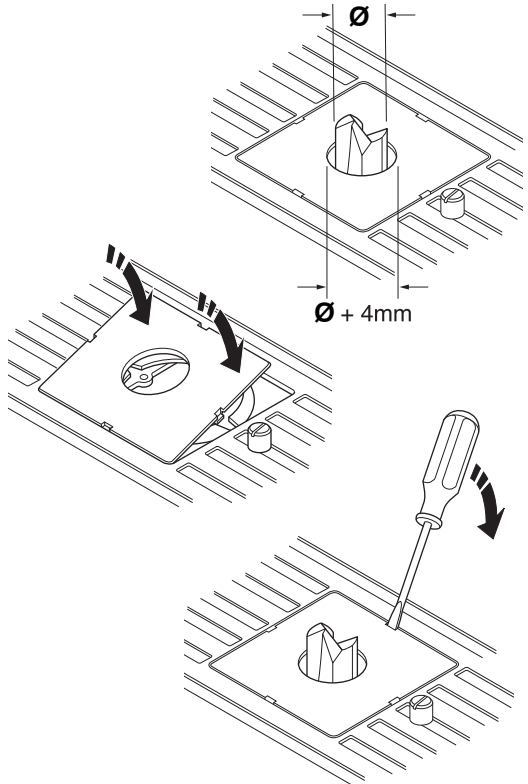
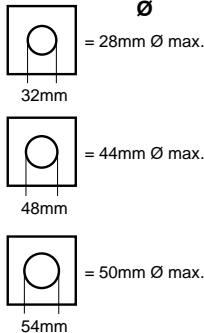

### Guard Operation

When routing with the top guard, never reach under the guard or swing the guard away. The guard should not be removed from the back fence and should always be used in the lowered position.

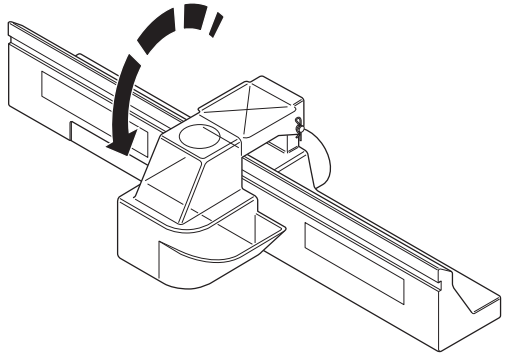

### Feed Direction

- Always work with constant, medium rate. Feeding too slow will result in burn marks and excessive heat build up of the cutter.
- Good results will be obtained by removing small amounts of material in several passes.
- Always feed work in the opposite direction to the direction of rotation of the router cutter.

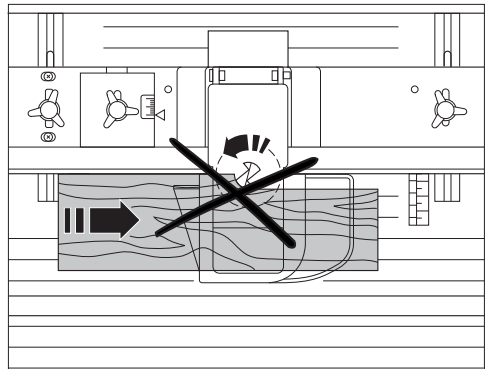
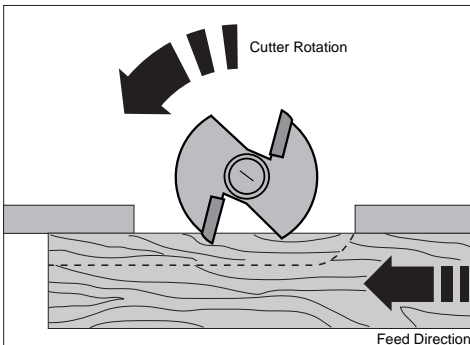
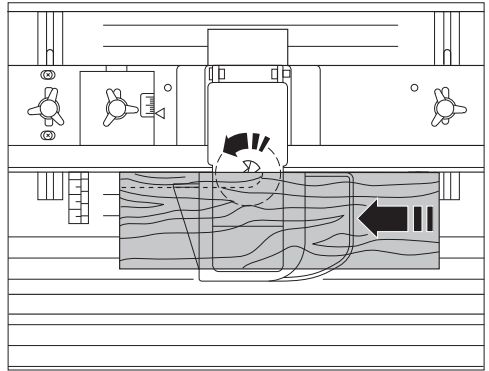

## ADJUSTMENT

### Fence Adjustments

To make adjustment to the lateral movement of the back fence:

- Release the back fence knob.
- Loosen the two screws that secure the adjustable wedge.
- Adjust position and re-tighten screws.
- Re-tighten the back fence knob.

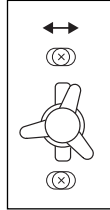

The back fence can be adjusted forwards and backwards, using the graduated scales to gauge the depth of mould.

For edge moulding, position the back fence with the fastening bolts towards the front of the slot.

For panel grooving (i.e. routing of grooves away from the edge of the workpiece) the fastening bolts should be to the rear of the holes and slots.

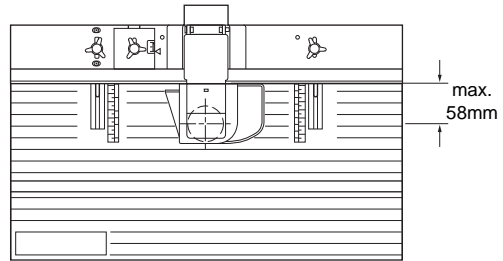
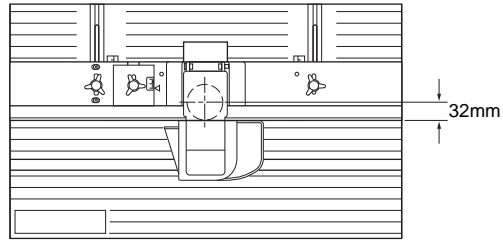

### Workpiece Support

The workpiece support provides safe guiding of the workpiece when routing the complete edge of the surface.

Adjustment range from:  
0 to 12.7mm (1/2")

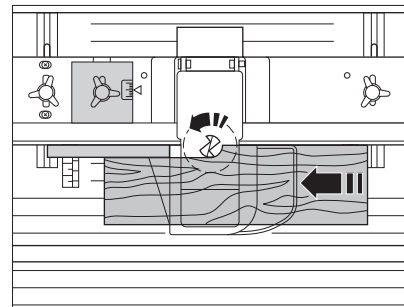

### Cutting Depth/Cutting Height

Before starting to work:

- Adjust the cutting depth (A) by adjusting the position of the back fence.
- Adjust the cutting height (B) by raising or lowering the cutter using a fine height adjuster (if fitted). Alternatively rapid height adjustment can be made if a PlungeBar is fitted.

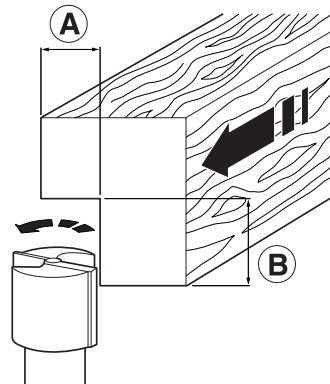

## OPTIONAL ACCESSORIES

### Hose and Connector - CRT/3 & CRT/4

The back fence is provided with an extraction point for connection to suitable vacuum extractors. The internal hole diameter is 58mm (2 1/4"). Suitable fittings with 58mm outside diameter are available for most extractor units.

- Only a vacuum extractor unit recommended for use in the workshop should be used.
- A suitable adaptor and extraction hose can be purchased as optional accessories.

The hose (Ref. CRT/4) has an outside diameter of 39mm and inside diameter of 32mm. The hose adaptor (Ref. CRT/3) is a three piece design that allows the hose to swivel freely.

- Assemble the hose adaptor onto the end of the hose as shown and insert into back fence.
- Fit the other end of the extraction hose to your dust extractor.

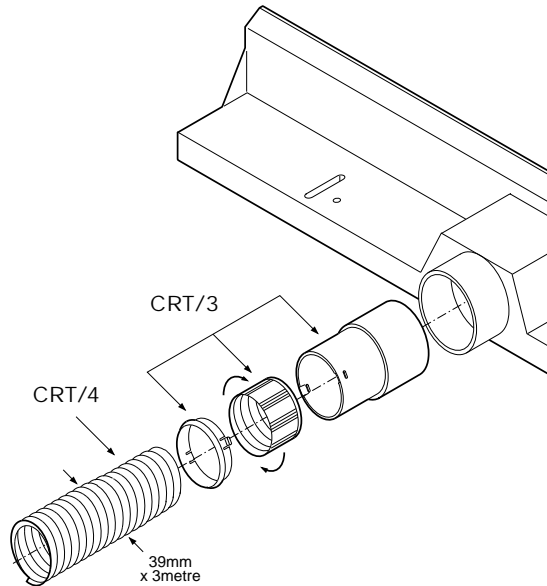

### Large capacity extraction hose - T30/22

A larger 58mm diameter hose 1.5 metres long with integral connector is available (Ref. T30/22) for fitting to the CRT and the Trend T30A vacuum extractor. This hose will provide an increased rate of air flow to improve extraction effectiveness.

- The hose is simply inserted into the back fence extraction point.

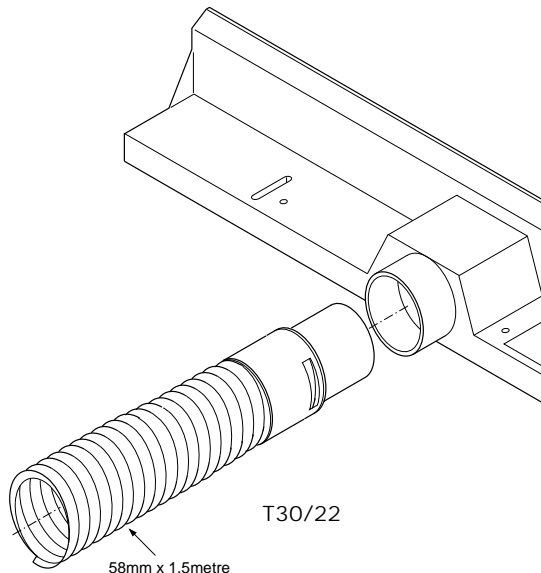

**Spring Pressure Clamps - CRT/10**

The optional spring pressure clamps can be mounted to the back fence. When adjusted to suit the width and thickness of the workpiece, they ensure the workpiece is held down onto the surface to obtain accurate machining of the workpiece.

- Remove back fence from table surface and assemble as shown.

**Adjustment**

- The spring pressure clamps will require adjusting to suit the height and width of workpiece being routed.
- The pressure strips should provide enough pressure to prevent the workpiece lifting from the table surface, but not too much as to create friction which would prevent the workpiece from sliding freely.
- The horizontal bar with pressure strip fitted can be removed from the vertical pillars when not required. The vertical pillars can be left in position and will not impede the tenon push back system.

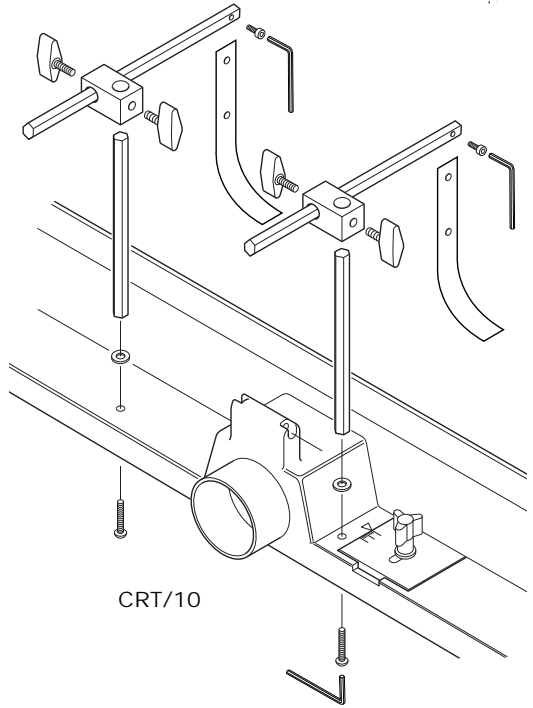

**Profiling Top Guard - CRT/2**

- Remove the back fence and assemble the profiling top guard as shown.

The use of the optional profiling top guard is recommended when profiling of workpieces with a pin or ball bearing guided cutter. It will prevent the operator's fingers inadvertently contacting the cutter while providing good visibility.

Pages 26 and 27 describe a typical application involving using ball bearing guided cutters with to make a shield.

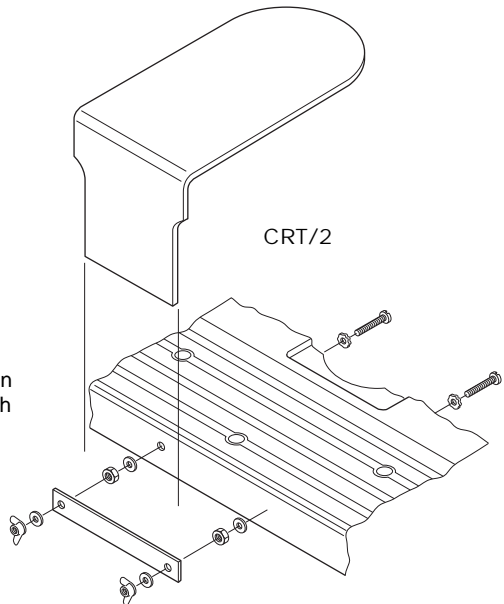

### Vertical Routing Support - CRT/5

For safe routing of narrow panels a vertical routing support is available.

- Assemble the support as shown.
- Adjust the depth of cut and router cutter height making sure the router is unplugged when making these adjustments.
- The vertical routing support should be positioned to guide the workpiece but allow it to slide freely.
- It is important to check that the entire length of the workpiece will travel between the fence and the support without binding. This is done simply by holding the workpiece up to clear the router cutter and passing it through the cutting area to ensure no binding occurs.
- Once the vertical routing support is positioned correctly lock it into place securely by tightening both knobs so that the vertical routing support will not move.

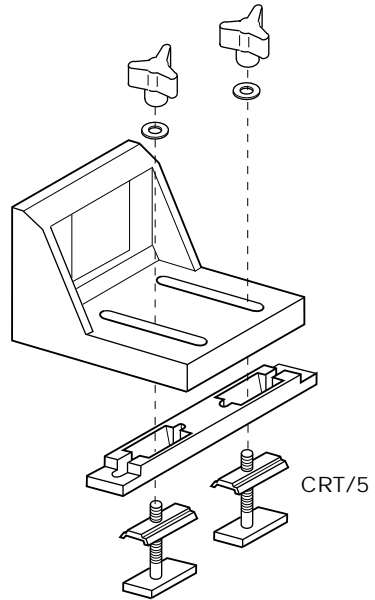

**IMPORTANT:**  
Do not overtighten the knobs as this may result in damage.

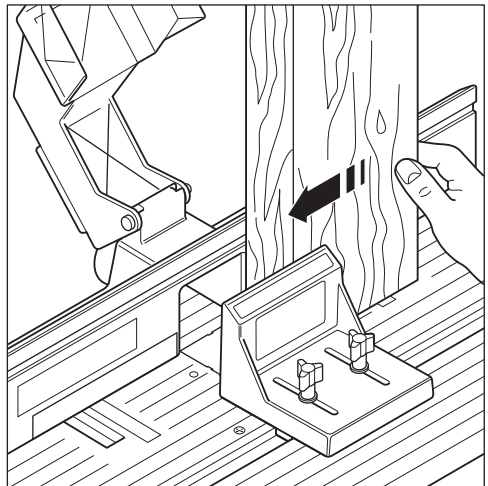

Floor Stand - CRT/FS

Always mount the routing table on a work table, bench or on the optional floor stand.



**IMPORTANT:** Please do not fit top screws until CRT/MK2 is fitted to the floor stand. Once CRT/MK2 is placed onto floor stand, the screws can be fitted.

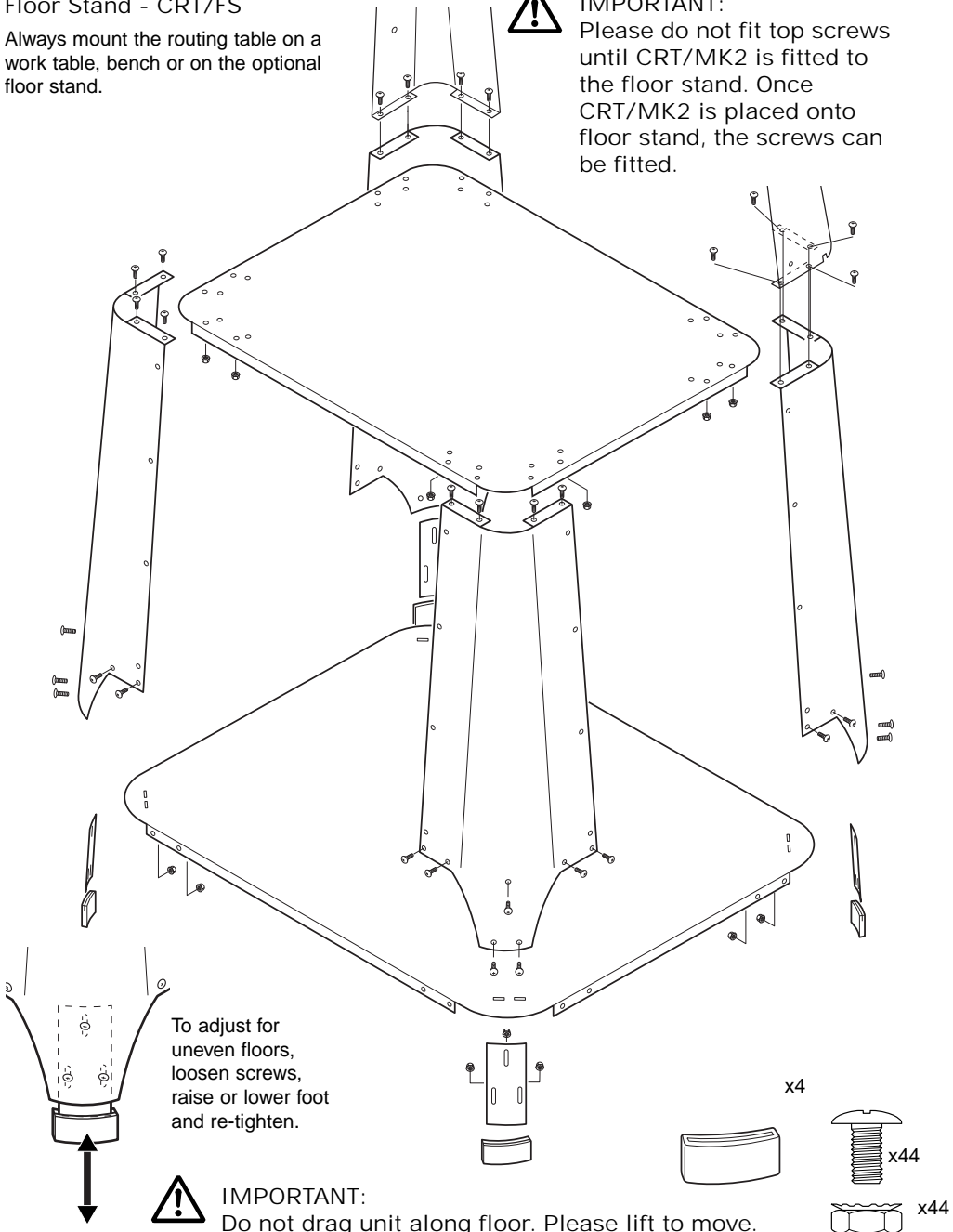

Enclosure Kit - CRT/EK

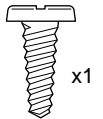
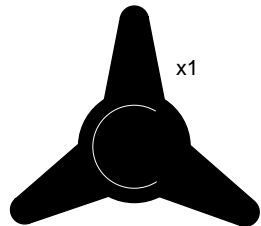
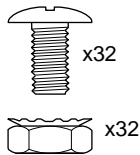
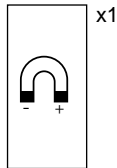
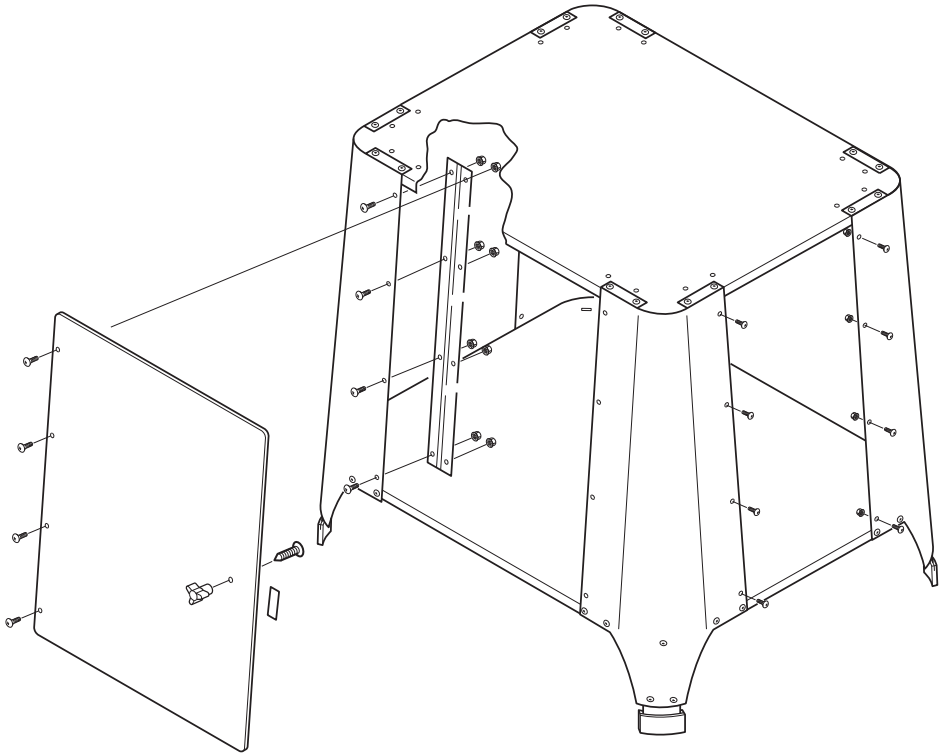

## OPERATION

### Edge moulding with the back fence

- Mark the width and depth of cut required onto the end of the timber and place it up against back fence.

- Release back fence fixing bolts and adjust position until required width of cut is achieved.

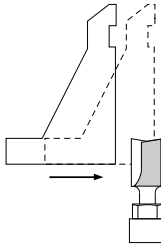

If pin or ball bearing guided cutters are used, ensure that the back fence is in line with the guide or slightly behind it. The back fence will give more support and provides the retractable safety guard and spring pressure clamp facility.

- Lock back fence fixing bolts.

- Release plunge mechanism on router and adjust the depth of cut using the fine height adjuster or PlungeBar (if fitted).

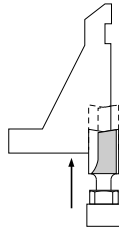

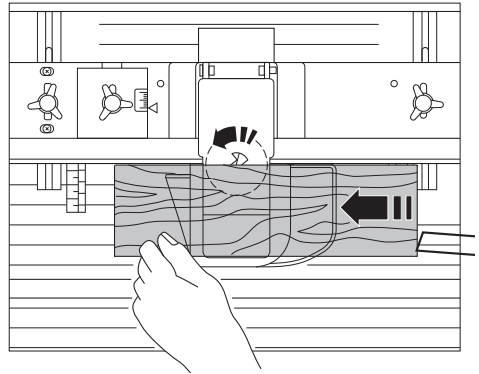

- Lock-off plunge mechanism of router.
- Lower guard and check it will retract freely over the workpiece.
- Adjust the spring pressure clamps (if fitted) to suit the thickness and width of the timber.
- Ensure that you have the pushstick within easy reach when routing.
- Switch on router and pass timber over cutter with a consistent feed speed.
- Ensure even pressure is kept on the workpiece down onto the table and against the back fence.



### IMPORTANT:

 Before making adjustments isolate the router and no-volt release switch from the power supply.

 Always ensure that hands are never near the cutter.

 Use the push stick to safely maintain pressure on narrow timbers.

### Useful Advice

Make a test cut on a piece of waste material prior to carrying out any routing operation.

### Examples of edge moulding cutters

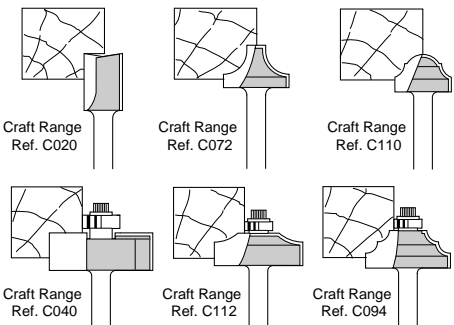

### Grooving with the Back Fence

The router table can be used for operations away from the edge of the workpiece such as grooving, fluting, veining, etc.

When routing, always feed against the rotation of the cutter. This direction is marked on the back fence.

For maximum accuracy, one edge of your workpiece (the edge sliding against the fence) must be true and straight.

Set up the back fence as follows:

- Raise safety guard and rest it against the extraction point.
- Position the fence behind the router bit for the desired cutting depth (the distance of cut from the edge of the workpiece).
- Securely tighten back fence fixing bolts and lower the guard over the cutter.
- Make the cut by sliding the straight edge of workpiece against the fence. Use the pushstick as shown.

### Full edge moulding using the Workpiece Support

The workpiece support can be used to plane an edge.

- The cutter should be set approximately 2mm proud of the back fence.
- The workpiece should be routed until the planed edge passes onto the out-feed fence.
- Retract workpiece away from cutters and switch off router.
- Replace workpiece and bring workpiece support out until it touches.
- Tighten knob and continue routing.

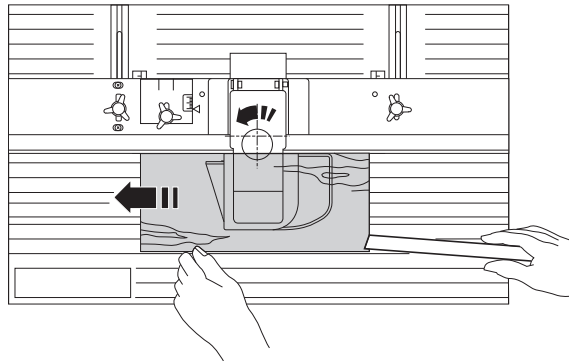

#### IMPORTANT!

Never push small or narrow workpieces by hand past the router cutter, unless a jig or pushstick/pushblock is used.



Always work with the guard lowered.



Adjust the cutting height and depth only when the power has been isolated and the router cutter stops rotating.

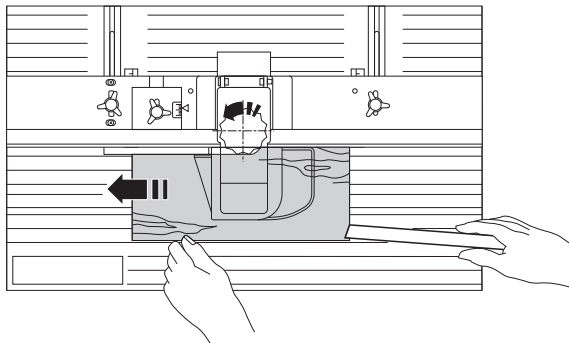

### Across grain routing with the mitre fence

The mitre fence will be required to give extra support for routing small workpieces or ends of large workpieces.

It is advisable to fit a waste piece of material to the mitre fence or behind the component to prevent break-out of the wood grain.

If using mitre fence to trim the end off a piece of material, the workpiece support can be brought forward with the cutter to support the workpiece after the cut.

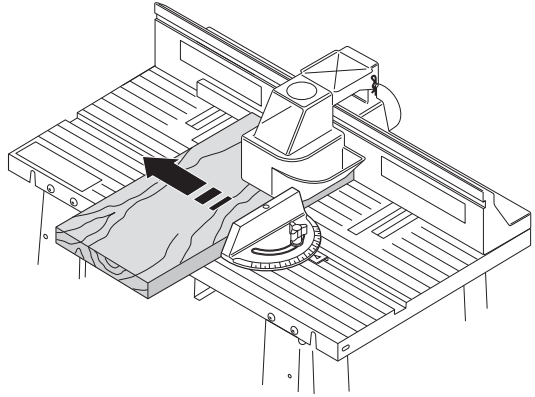

#### IMPORTANT!

Align back fence with the mitre bar slot before using mitre fence.

### Stopped Moulding

Right hand (A) and left hand (B) stops, constructed from scrap timber, must be attached to the back fence using clamps. These stops limit the movement of the workpiece, and should be set to suit the required stopped mould length.

1. Swing in the workpiece around the corner (C) keeping the workpiece edge (D) up against the right hand stop (A), until the router cutter plunges into the workpiece.
2. Rout the complete length of the workpiece, until the workpiece touches the left hand stop (B).
3. Swing out the workpiece (D) around the corner point (C).

1

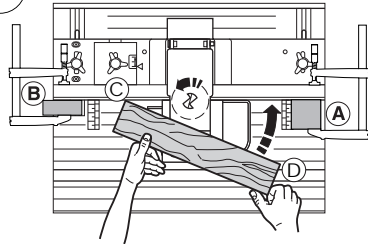

2

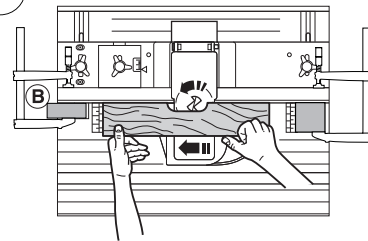

3

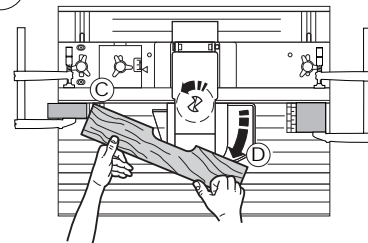

#### IMPORTANT!

There is a danger of kick-back, unless the stops are used.

## Tenon Cutting using the Push Tenon Block

The tenon push block facility is ideal for producing tenons and sliding dovetails.



### IMPORTANT!

The retractable guard cannot be used when carrying out push block operations. Therefore extra care must be taken to ensure that hands are kept well clear of the cutter.

- Ensure that the workpiece is true and the end is square and smooth.
- Mount push block assembly on the back fence.
- Adjust the height and depth of the cutter to suit the cut required.
- Position workpiece between clamp plate and push block so that its side is flush against the face of the back fence, and the end to be cut is resting on the table. Clamp workpiece in this position by tightening the wing nut on the clamp rod while making sure that clamp plate stays orientated on the workpiece.
- Slide push block and workpiece back to the start position. When routing, always feed against the rotation of the cutter.
- Switch router on and guide the push block against the back fence with both hands, keeping fingers at a safe distance from cutter.
- Switch router off, unclamp workpiece and slide push block back to its original position.
- Position and re-clamp each side of workpiece and repeat cutting operations.

### Useful advice.

When setting up, a piece of paper placed between the compact and table top will give sufficient gap to slide properly.

A scrap piece of timber should be placed behind the workpiece to prevent break-out.

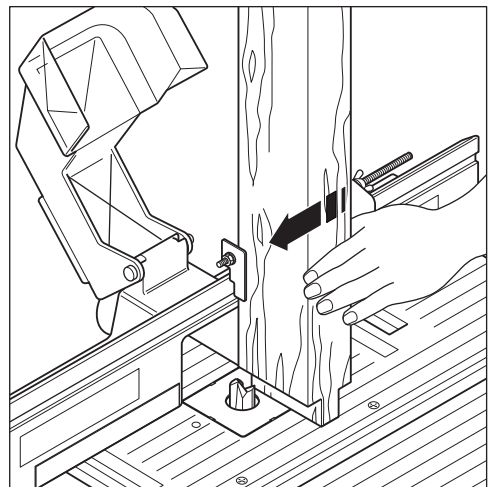
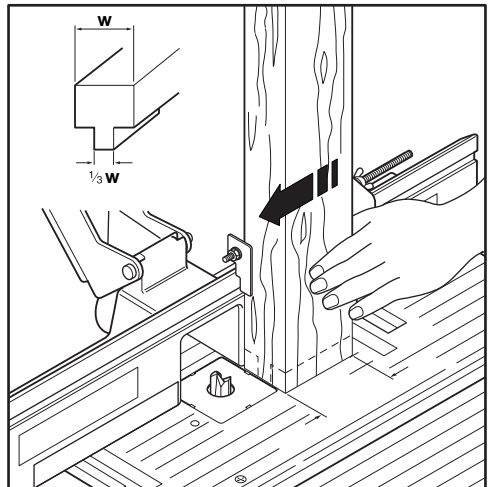

### Routing without a Back Fence



**IMPORTANT!**  
There is an increased danger of injury since the router cutter is freely accessible from all sides.



Fit the profiling top guard for protection and the lead-on pin to prevent kick-back.

- Only use router cutters with a ball bearing or pin guide.
- Always work against the direction of rotation of the router cutter.

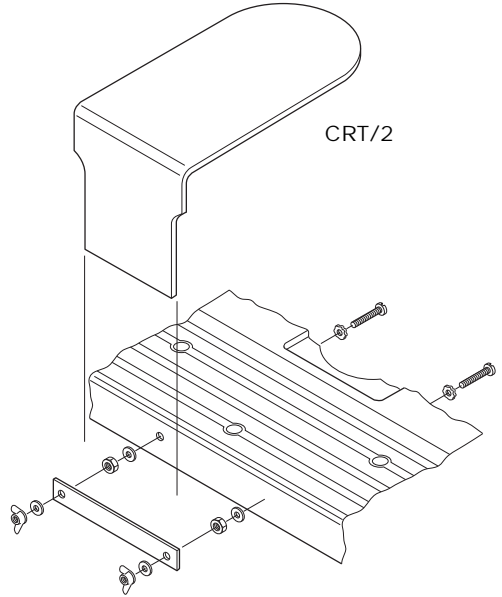

### Mounting a Lead-on Pin

- The lead-on pin should be screwed into the table top as shown and tightened with a flat screwdriver.

The pin is used as a guide for the workpiece when the cut is first made. Correct working procedure for this is critical especially when using large diameter cutters.

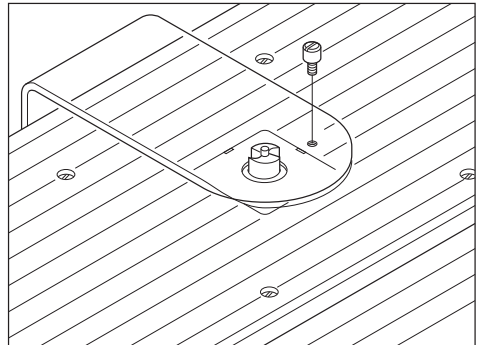

### Profiling Working Procedure

- Switch router on and allow it to reach full running speed.
- Position the workpiece against the lead-on pin as shown. The workpiece should not contact the cutter.
- Gradually swing workpiece towards cutter until workpiece or template engages the ball bearing or pin guide.
- Feed workpiece against the rotation of the cutter whilst swinging the workpiece away from the lead-on pin. At this point the ball bearing is acting as the guide.

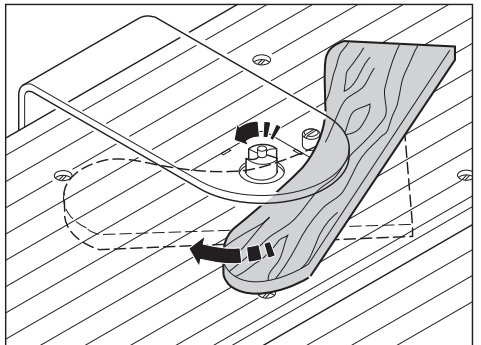

- Progressively feed the workpiece anti-clockwise around the shape of the template ensuring that the ball bearing always stays in contact with the workpiece.
- When the complete edge of the workpiece has been machined, slide it away from the cutter.
- If you are unfamiliar with the above procedure then the technique should be practised before switching on the router.

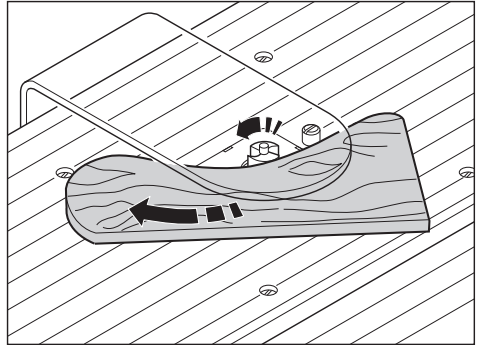

#### Helpful Advice

- Always keep the workpiece moving in a precise steady movement to prevent the workpiece from burning.
- Never let go of the workpiece. Always keep an even pressure of the workpiece against the bearing. Do not use too much pressure.
- If you wish to stop routing halfway through the operation. Simply slide the workpiece away from the cutter before switching off the router.
- If the workpiece inadvertently comes away from the ball-bearing and so does not complete the cut correctly, do not stop. Complete the operation and repeat the procedure for the edge concerned.
- It is usually advisable to repeat the operation in order to improve the finish of the workpiece.
- Keeps hands away from the cutter, even if the guard is fitted, in order to give a good safety margin.
- If natural woods are used, consideration should be given to break-out of short grain which will effect your decision as to where to start the routing operation in order to prevent it.

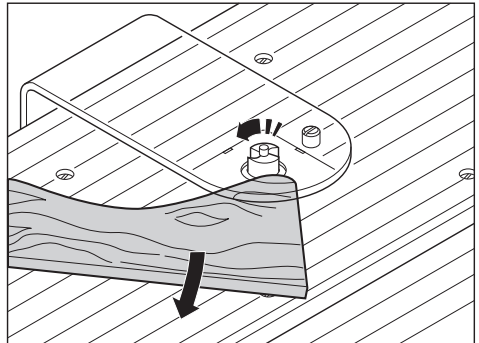

## EXAMPLE APPLICATION

### Producing a Shield

- Construct an actual size template of the design from 6mm MDF or plywood ensuring that it is accurate and free from imperfections.
- Fix the template to the back of the workpiece to be used using screws or double sided tape.
- Rough cut the workpiece to the shape of the template using a band saw or jigsaw leaving 2-3mm oversize.
- Fit a ball bearing guided trimmer cutter.
- Lay the workpiece (with template fitted) face down on the table surface. Adjust the height of the cutter. Ensure that the ball bearing will contact the template and the cutting edge of the cutter will machine the full edge of the workpiece.
- Fit the profiling top guard and adjust height to give a 6mm gap between the top of cutter and underside of template.
- Switch router on and position the workpiece against the lead-on pin as shown. The workpiece should not contact the cutter.
- Rout the shield using the procedure described on the previous pages.

### Useful advice

If natural woods are used, consideration should be given to break-out of short grain which will effect your decision as to where to start the routing operation in order to prevent it.

### Moulding the Shield

A suitable ball bearing guided cutter should be chosen to mould the shield.

- Fit chosen moulding cutter and adjust height of cutter to achieve shape required.
- If the full edge of the workpiece is to be machined, leave the template attached to the workpiece so as to provide a guide for the ball bearing. Otherwise the template can be removed, providing there is sufficient edge for the ball bearing to follow.
- Repeat the same routing procedure as before.

If the profile required involves excessive removal of material, it is advisable to take two passes with the cutter. First reduce the height of the cutter protruding from the table, this in effect, reduces the amount of material which will be removed, or fit a larger ball bearing, if one is available for that particular cutter.

The second pass can then be made to give the required finish.

Carrying out this two stage routing operation has many advantages.

- Improved finish on workpiece
- Less load on cutter and router
- Far less risk of workpiece snatching

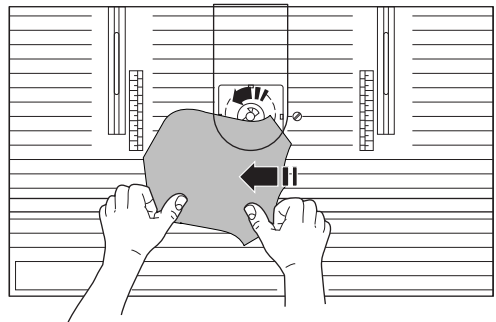

### Definition of Snatching

This can be described as the cutter catching the workpiece and projecting it away from the direction of rotation. The workpiece is often taken from the operator's hands and projected across the work area. It can have potentially dangerous consequences if the cutter is unguarded and/or the operator's hands are too close to the cutter. Damage to the cutter can also be caused.

The following precautions should be made to avoid a potentially dangerous situation:

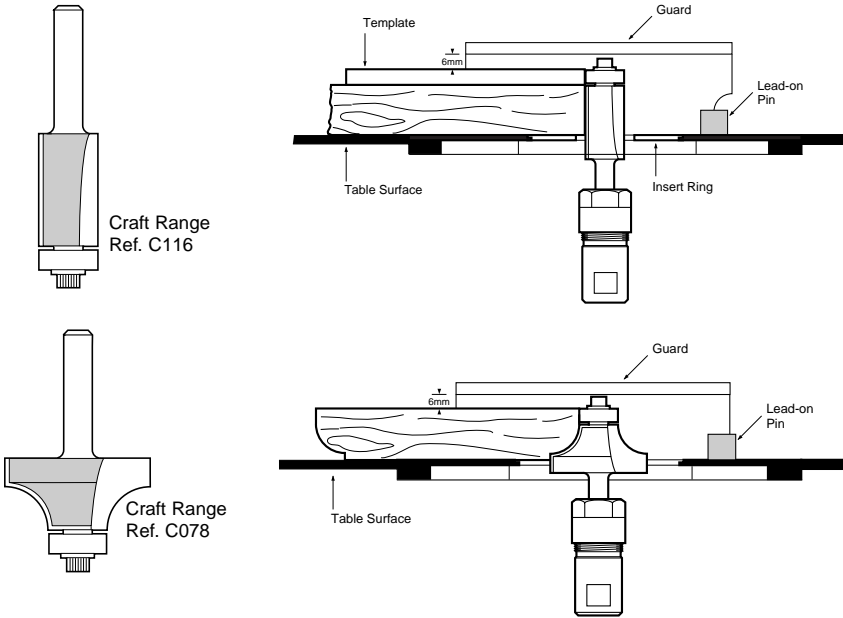

- Fit the profiling top guard, this will prevent fingers contacting the cutter.
- Always rout in the direction which opposes the direction of rotation of the cutter. Routing with the direction of the cutter is called back-cutting and will cause snatching and therefore should not be carried out.
- Use the lead-on pin to provide support for the workpiece during the initial start of the routing operation, it will also ensure that you approach the cutter from the correct side.
- When a deep cut is required or the workpiece is particularly dense, then take two or three passes.
- Ensure the cutter always has sharp cutting edges.

#### Useful advice

- Do not reduce pressure of the workpiece or let go of it. Always keep both hands on the workpiece and keep an even pressure against the ball bearing.
- Do not use too great a feed speed. If the revolutions of the router drop, it is a good indication that either too deep a pass is being made and/or the cutter is blunt. Therefore reduce the depth of cut and/or re-sharpen your cutter.

If the above points are followed, profile routing using bearing guided cutters is both safe and rewarding. It is however advisable for those new to routing to avoid using larger diameter cutters until proficient with the technique described. Under no circumstances should this type of operation be attempted with cutters not having a ball bearing or guide pin.

CRT/MK2 & ACCESSORIES - SPARE PARTS LIST			v2.0 10/1999
Item	Qty	Description	Ref.
1	1	Table Top	WP-CRTMK2/01
2	2	Table Leg	WP-CRTMK2/02
3	4	Washer 7.2mm X 19mm X 1.5mm	WP-CRT/03
4	2	Bolt Carriage UNC1/4"-20 X 1.3/4"	WP-CRT/04
5	34	Nut/Star Washer UNF10-30	WP-CRTMK2/05
6	1	Mitre Fence Bar	WP-CRTMK/06
7	34	Machine Screw Pan UNF10-32 X 1/2" PH	WP-CRTMK2/07
8	1	Back Fence Wedge	WP-CRTMK2/08
9	4	Machine Screw Csk UNF10-32 X 3/4" PH	WP-CRTMK2/09
10	1	Mitre Fence Head	WP-CRTMK2/10
11	1	Mitre Fence Knob UNC10-24	WP-CRT/11
12	1	Extension Table Support LH	WP-CRTMK2/12
13	1	Extension Table Support RH	WP-CRTMK2/13
14	1	Extension Table Left	WP-CRTMK2/14
15	1	Washer 5.2mm X 14.2mm X 1mm	WP-CRT/15
16	1	Extension Table Right	WP-CRTMK2/16
17	1	Back Fence	WP-CRTMK2/17
18	1	Safety Guard	WP-CRTMK2/18
19	1	Guard Pivot Pin	WP-CRTMK2/19
20	1	Workpiece Support	WP-CRT/20
21	1	Push Block	WP-CRT/21
22	1	Clamp Rod UNC5/16"-18	WP-CRT/22
23	1	Clamp Plate For	WP-CRT/23
24	1	Bolt Hex UNC1/4"-20 X 1"	WP-CRT/24
25	1	Guard Pivot Pin Clip	WP-CRTMK2/25
26	1	Wing Nut UNC5/16"-18	WP-CRT/26
27	1	Washer 9mm X 17.5mm X 1.5mm	WP-CRT/27
28	2	Scale Metric/Imperial	WP-CRTMK2/28
29	1	Washer Split Spring UNF1/4"	WP-CRT/29
30	3	Knob UNC1/4"-20	WP-CRTMK2/30
32	1	Table Top Label	WP-CRTMK2/32
33	1	Label Fence Trend	WP-CRTMK2/33
34	1	Label Warning	WP-CRTMK2/34
35	2	Machine Screw Pan UNF10-32 X 7/8" PH	WP-CRTMK2/35
36	1	Nut Hex UNF1/4"-28	WP-CRT/36
37	1	Screw Self Tapping 4.8mm x 12.7mm PH	WP-CRTMK2/37
38	1	Lead On Pin	WP-CRTMK2/38
39	1	Insert Ring 32mm ID	WP-CRTMK2/39
40	1	Insert Ring 48mm ID	WP-CRTMK2/40
41	1	Insert Ring 54mm ID	WP-CRTMK2/41
42	1	Fixing Pack For Plate A	WP-CRTMK2/42

CRT/MK2 & ACCESSORIES - SPARE PARTS LIST			v2.0 10/1999
Item	Qty	Description	Ref.
43	1	Fixing Pack For Plate B	WP-CRTMK2/43
44	1	Fixing Pack For Plate C	WP-CRTMK2/44
45	1	Fixing Pack For Plate D	WP-CRTMK2/45
46	0	Fixing Plate A With Screws	CRT/FP/A
47	0	Fixing Plate B With Screws	CRT/FP/B
48	0	Fixing Plate C With Screws	CRT/FP/C
49	0	Fixing Plate D With Screws	CRT/FP/D
50	0	Mitre Fence Complete	WP-CRTMK2/50
51	0	Push Block Complete	WP-CRT/51
52	0	Back Fence Complete	WP-CRTMK2/52
53	1	Bolt Carriage UNC10-24 X 3/4"	WP-CRTMK2/53
91	1	No Volt Release Switch 230v UK Plug	NVRS/230V
	0	No Volt Release Switch 230v Euro Plug	NVRS/230V/EUR
92	0	Fixing Pack For Switch	WP-NVRS/01
93	1	Spanner 9.5mm A/F Pressed Steel	WP-SPAN/95P
94	1	Manual	MANU/CRT
96	1	Plastic Pushstick	PUSHSTICK/1
<b>CRT/EK</b>			
5	32	Nut/Star Washer UNF10-30	WP-CRTMK2/05
37	1	Screw Self Tapping 4.8mm X 12.7mm PH	WP-CRTMK2/37
80	1	Enclosure Kit Door Panel	WP-CRTMK2/80
81	2	Enclosure Kit Side Panel	WP-CRTMK2/81
82	1	Enclosure Kit Hinge	WP-CRTMK2/82
83	1	Enclosure Kit Back Panel	WP-CRTMK2/83
85	8	Machine Screw Pan UNC10-32 X 3/8" PH	WP-CRTMK2/85
86	1	Enclosure Kit Knob	WP-CRTMK2/86
87	1	Magnetic Latch	WP-CRTMK2/87
<b>CRT/FS</b>			
5	44	Nut/Star Washer UNF10-30	WP-CRTMK2/05
7	44	Machine Screw Pan UNF10-32 X 1/2" PH	WP-CRTMK2/07
75	4	Leg Stand Leg Assembly	WP-CRTMK2/75
76	1	Leg Stand Top Shelf	WP-CRTMK2/76
77	1	Leg Stand Bottom Shelf	WP-CRTMK2/77
78	4	Leg Stand Adjustable Foot	WP-CRTMK2/78
79	4	Leg Stand Rubber Foot	WP-CRTMK2/79
<b>CRT/2</b>			
54	2	Washer 5.3mm X 9.8mm X 1.0mm	WP-WASH/09
55	2	Wing Nut M5	WP-NUT/11

CRT/MK2 & ACCESSORIES - SPARE PARTS LIST			v2.0 10/1999
Item	Qty	Description	Ref.
57	1	Clamping Plate	WP-CRT/57
58	2	Nut Hex M5	WP-NUT/05
59	2	Spring Washer M5	WP-WASH/29
60	2	Star Washer M5	WP-WASH/39
61	2	Machine Screw Pan M5 X 20mm Slot	WP-SCW/16
62	1	Perspex Guard	WP-CRT/62
<b>CRT/3</b>			
97	1	Adaptor Tube	WP-CRT/97
98	1	Adaptor Fitting	WP-CRT/98
99	1	Adaptor Clip	WP-CRT/99
<b>CRT/5</b>			
3	2	Washer 7.2mm x 19mm x 1.5mm	WP-CRT/03
31	1	Workpiece Support Knob UNC1/4"-20	WP-CRT/31
71	1	Vertical Support Fence Body Only	WP-CRT/71
72	1	Guide Track For Vertical Support	WP-CRT/72
73	2	Wedge For Vertical Support	WP-CRT/73
74	2	Bolt For Guide Track Vertical Supp UNC1/4"-20 X 1.3/8"	WP-CRT/74
95	1	Instructions for CRT/5	INST/CRT/5
<b>CRT/10</b>			
56	2	Machine Screw Socket M5 X 10mm	WP-SCW/20
63	2	Machine Screw Socket M6 X 20mm	WP-SCW/29
64	2	Washer M6	WP-WASH/50
65	2	Vertical Pillar	WP-CRT/65
66	2	Connecting Block	WP-CRT/66
67	4	Knob M6 X 10mm	WP-KNOB/01
68	2	Horizontal Bar	WP-CRT/68
70	2	Pressure Strip	WP-CRT/70
88	1	Hex Key 4mm A/F	WP-AP/04
89	1	Hex Key 3mm A/F	WP-AP/03

CRT/MK2 & ACCESSORIES - SPARE PARTS LIST			v2.0 10/1999
Item	Qty	Description	Ref.
57	1	Clamping Plate	WP-CRT/57
58	2	Nut Hex M5	WP-NUT/05
59	2	Spring Washer M5	WP-WASH/29
60	2	Star Washer M5	WP-WASH/39
61	2	Machine Screw Pan M5 X 20mm Slot	WP-SCW/16
62	1	Perspex Guard	WP-CRT/62
<b>CRT/3</b>			
97	1	Adaptor Tube	WP-CRT/97
98	1	Adaptor Fitting	WP-CRT/98
99	1	Adaptor Clip	WP-CRT/99
<b>CRT/5</b>			
3	2	Washer 7.2mm x 19mm x 1.5mm	WP-CRT/03
31	1	Workpiece Support Knob UNC1/4"-20	WP-CRT/31
71	1	Vertical Support Fence Body Only	WP-CRT/71
72	1	Guide Track For Vertical Support	WP-CRT/72
73	2	Wedge For Vertical Support	WP-CRT/73
74	2	Bolt For Guide Track Vertical Supp UNC1/4"-20 X 1.3/8"	WP-CRT/74
95	1	Instructions for CRT/5	INST/CRT/5
<b>CRT/10</b>			
56	2	Machine Screw Socket M5 X 10mm	WP-SCW/20
63	2	Machine Screw Socket M6 X 20mm	WP-SCW/29
64	2	Washer M6	WP-WASH/50
65	2	Vertical Pillar	WP-CRT/65
66	2	Connecting Block	WP-CRT/66
67	4	Knob M6 X 10mm	WP-KNOB/01
68	2	Horizontal Bar	WP-CRT/68
70	2	Pressure Strip	WP-CRT/70
88	1	Hex Key 4mm A/F	WP-AP/04
89	1	Hex Key 3mm A/F	WP-AP/03

CRT/MK2 & ACCESSORIES - SPARE PARTS DIAGRAM

v2.0 10/1999

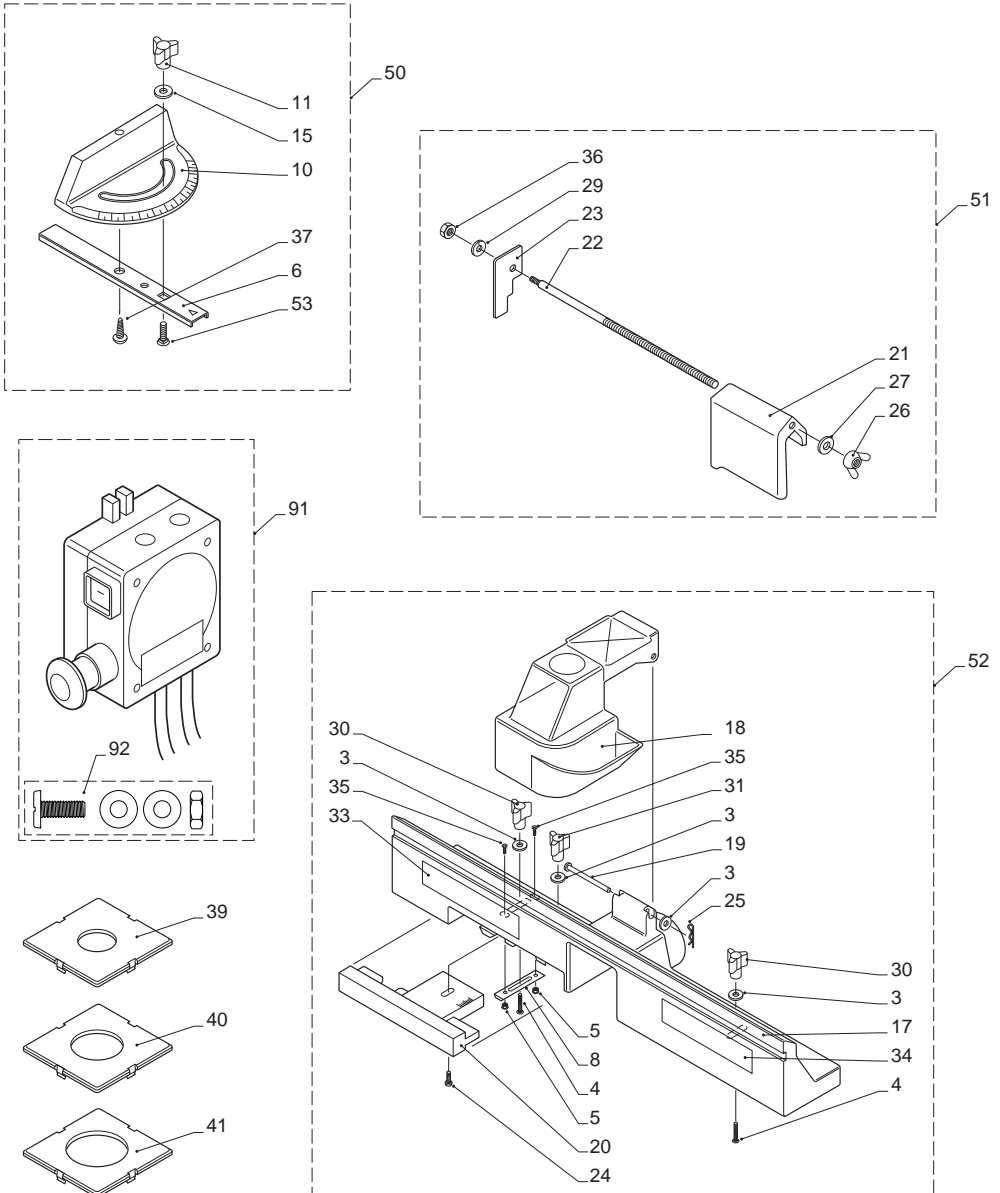

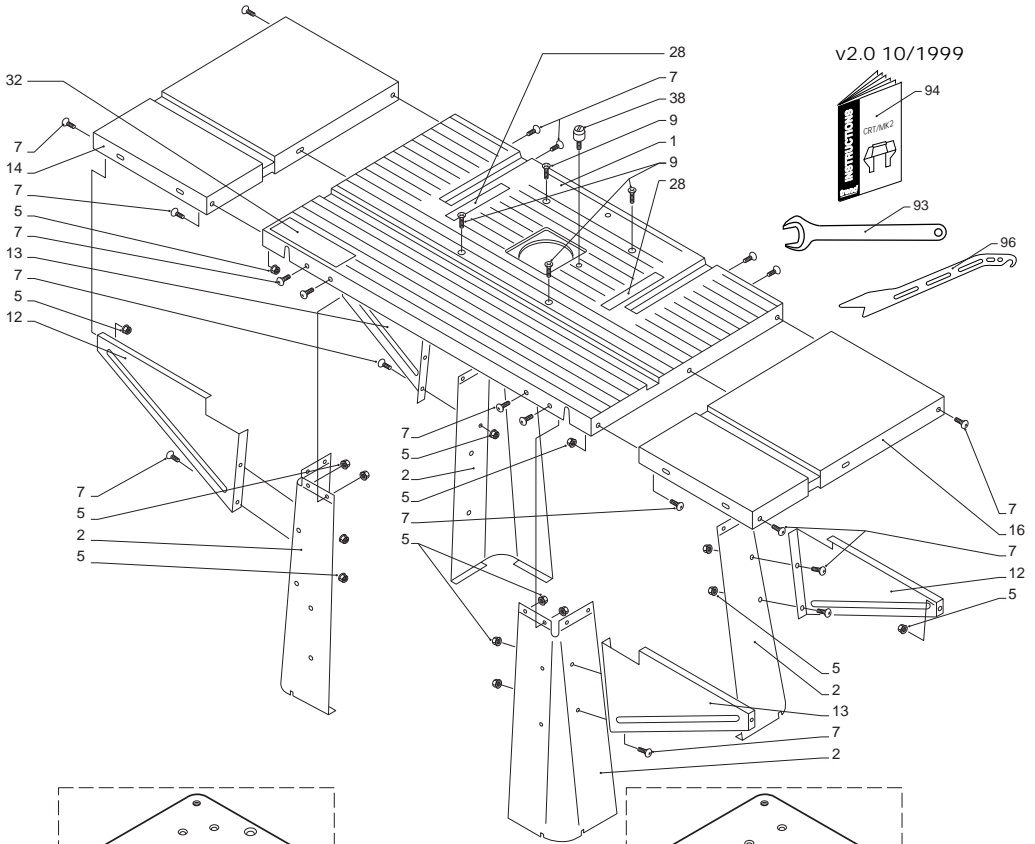

v2.0 10/1999

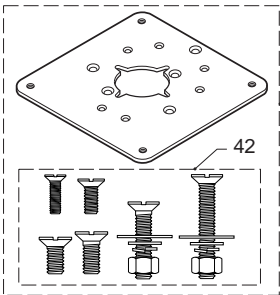
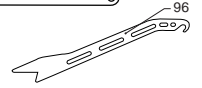
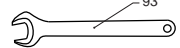

46

42

CRT/FP/A

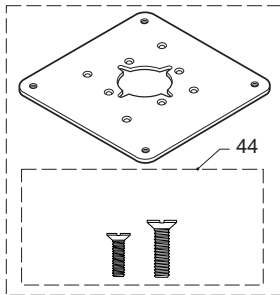

48

44

CRT/FP/C

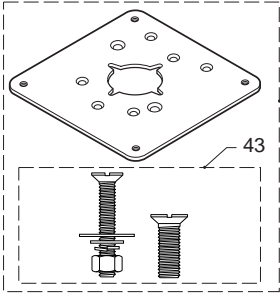

47

43

CRT/FP/B

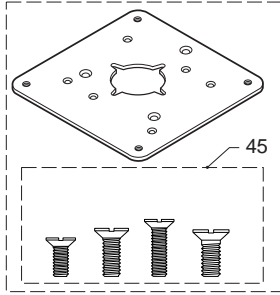

49

45

CRT/FP/D

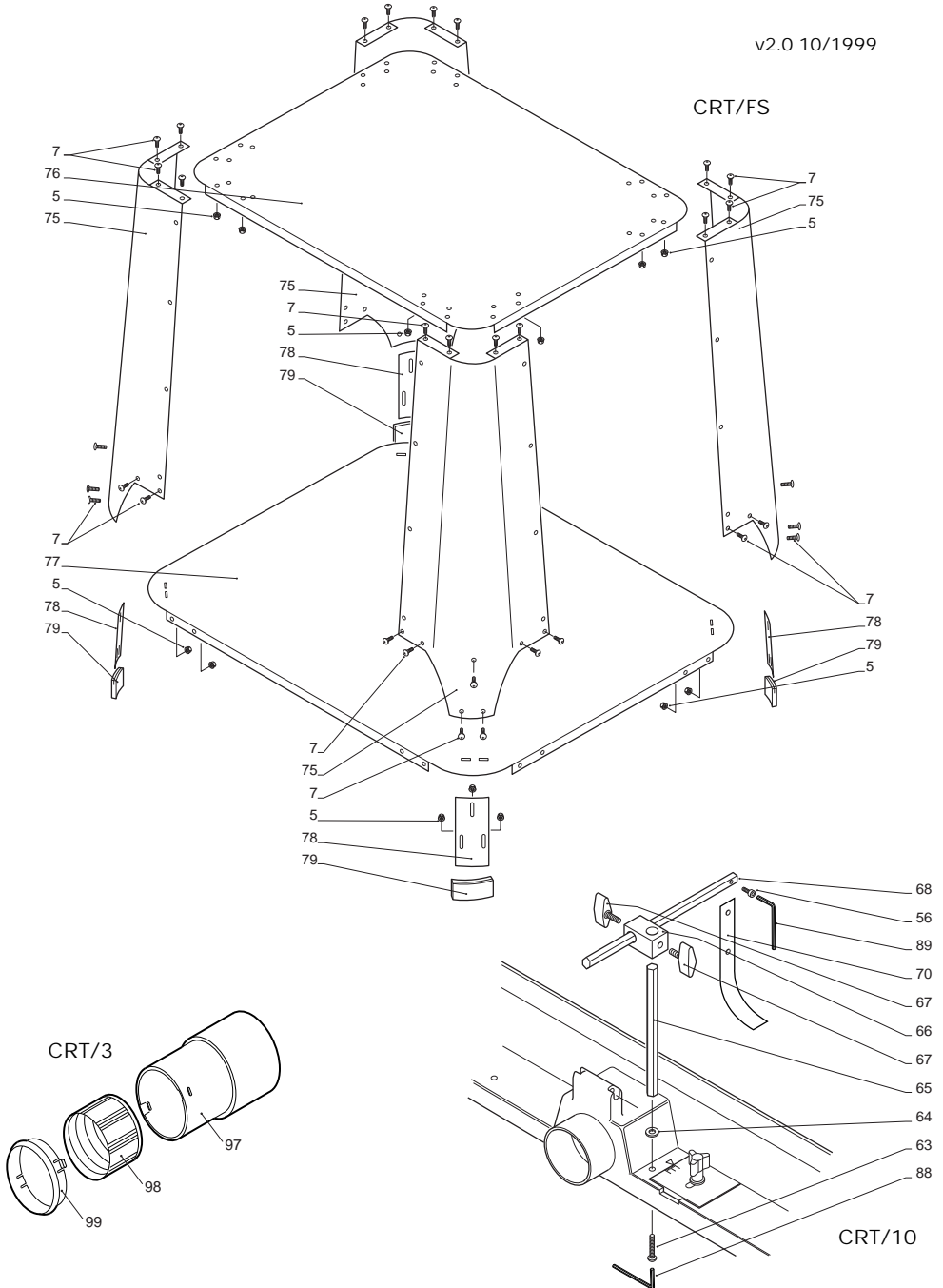

v2.0 10/1999

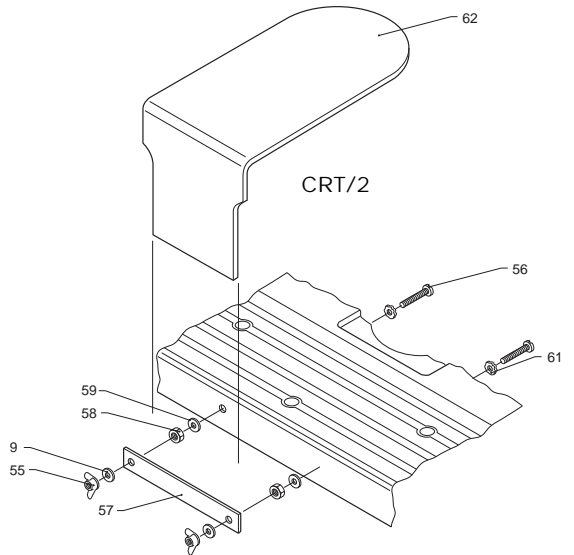
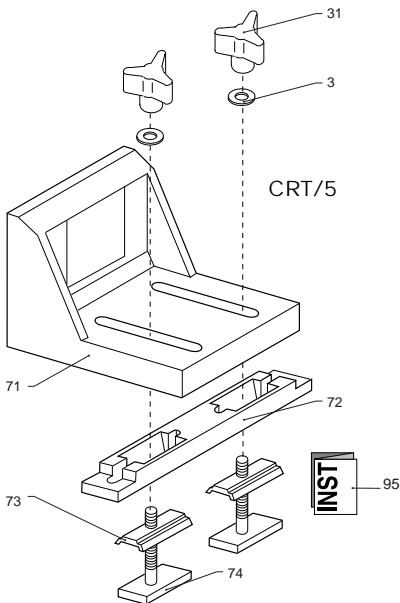
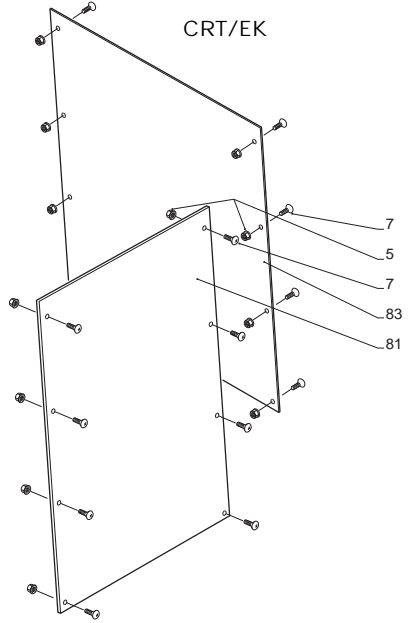
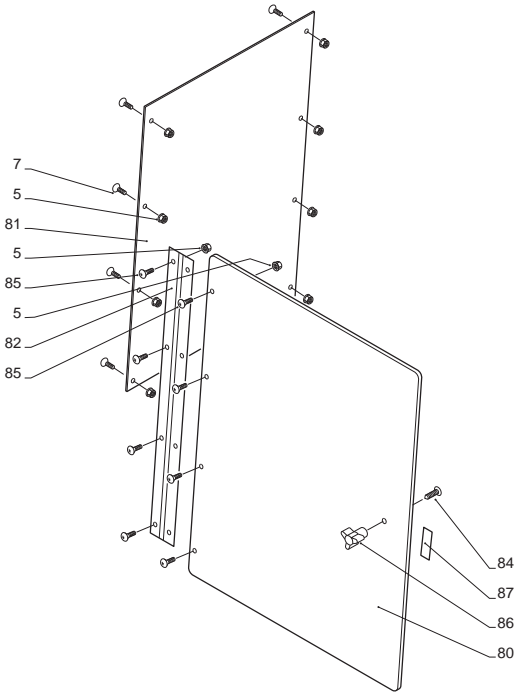

### Maintenance and Cleaning

Before all work on the router table itself, pull the mains cable out of the socket and not the router cable out of the no-volt release switch.

Always keep the table clean. After operation, clean the woodchip, dust and waste away from the table.

Do not use PTFE spray on the plastic components of the table.

### Guarantee

- The router table carries a manufacturers guarantee in accordance with the conditions on the enclosed guarantee card.

### Recycling

- Router table, accessories and packaging should be sorted for environmentally friendly recycling.

MANU/CRT v4 .0



RECYCLABLE

**Trend Machinery & Cutting Tools Ltd.**

Unit 6 Odhams Trading Estate

Watford WD2 5TR England

**Enquiries:** \_\_\_\_\_ 0800 487363

**Technical Support:** \_\_\_\_\_ 01923 224681

**Fax:** \_\_\_\_\_ 01923 236879

**Email:** \_\_\_\_\_ mailserver@trendm.co.uk

**WWW:** \_\_\_\_\_ www.trendm.co.uk