

JOINABOARD

JOINTING JIG



trend[®]
routing technology

ITEMS ENCLOSED

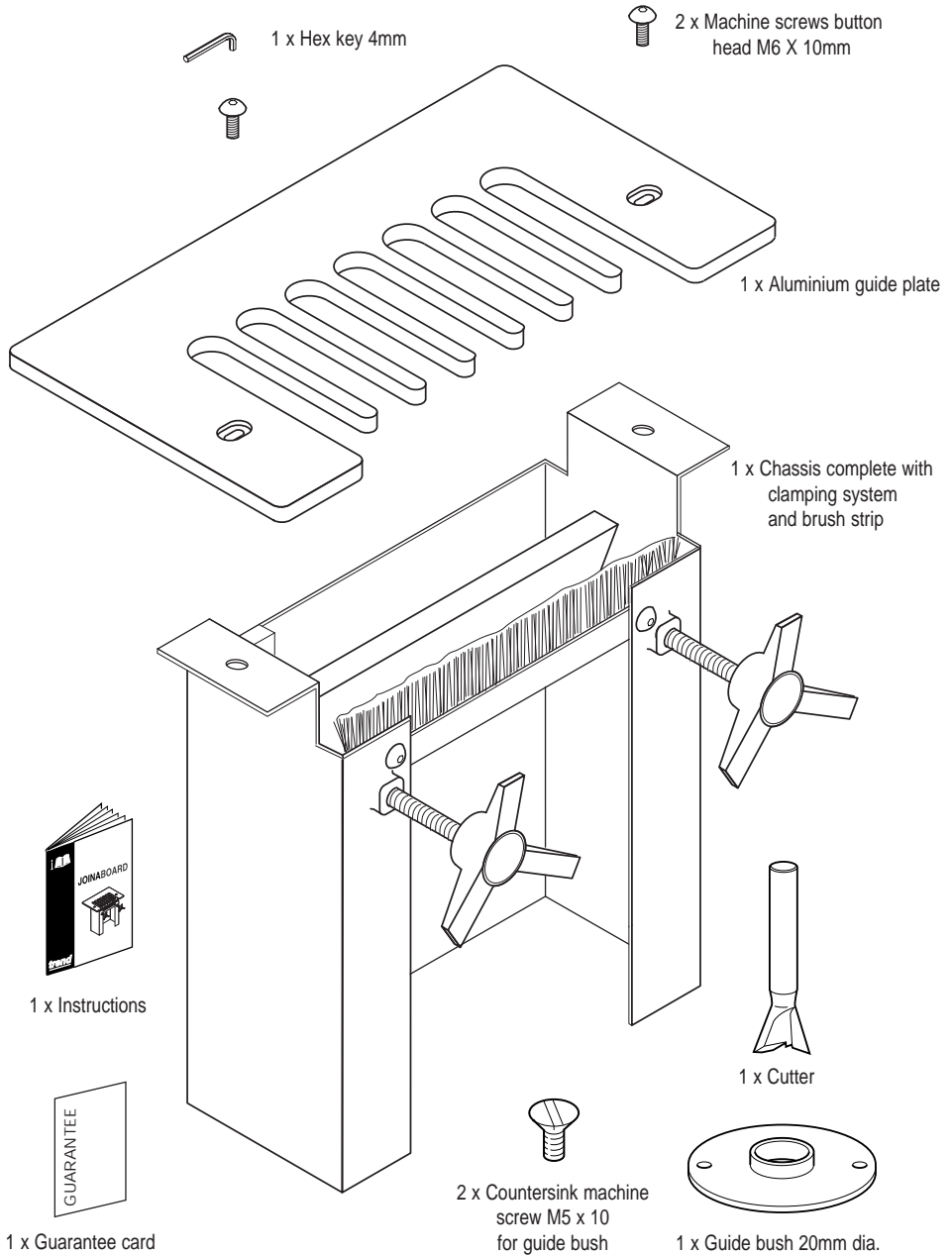

SAFETY PRECAUTIONS

- Always switch off the power and unplug the router when changing cutters or when making adjustments.
- Always wear protective goggles when routing.
- Wear sound protective ear muffs when routing for long periods of time.
- Always wear a dust mask. Use dust extraction equipment whenever possible.
- Do not wear loose clothing. Make sure baggy sleeves are rolled up and ties are removed.
- Always remove spanners and hex keys from the workpiece before switching router on.
- Keep hands well clear of the router cutter when routing.
- Avoid accidental starting of the router. Make sure the power switch is in the 'Off' position before plugging in and connecting to the electrical supply.
- Never leave the router unattended when running. Always wait until the router comes to a complete stop before making any adjustments.
- Do not switch the router on with the cutter touching the workpiece.
- Mount the workpiece securely to a work bench or to a workboard fitted to a suitable surface.
- Periodically check all nuts and bolts to make sure they are tight and secure.

Cutter Care

- Do not drop cutters or knock them against hard objects.
- Cutters should be kept clean. Resin build-up should be removed at regular intervals with Resin Cleaner[®]. The use of a dry lubricant will act as a preventative such as Trendicote[®] PTFE spray.
- Cutter shanks should be inserted into the collet at least $\frac{3}{4}$ of shank length to prevent distortion. A distorted collet should be discarded, as it can cause vibration and damage the shank.

- Do not over-tighten collet as this will score the shank and create a weakness there.
- It is also advisable to periodically check the router collet nut for wear.

Useful Advice

- Judge your feed rate by the sound of the motor. In time, the operator will acquire a 'feel' for the router, and a feed speed relative to the work will come naturally. Too slow a feed will result in burning.
- Apply the normal precautions as with any electric power tool.
- The main abuse of routing machines is the inclination for operators to overload them. The motto is 'Keep the revs up'. The drop in revolutions should not exceed, if possible, more than 20% of full running speed.
- The motor of a router is susceptible to the accumulation of sawdust and wood chips, and should be blown out, or 'vacuumed', frequently to prevent interference with normal motor ventilation.
- Refer to the Instruction Manual supplied with your router for full details of its features and safety information.
- Trial cuts should be made on waste material before starting any project.

ACCESSORIES

Sub-base Sets

To obtain an accurate close fitting joint, a 30mm guide bush must be used. The guide bush must always be fitted concentrically to the cutter. This can be achieved using a Trend sub-base and 30mm outside diameter guide bush (ref. GB30).

Trend sub-bases have a central recess to allow fitting of the Trend guide bush, to most makes of routers and are available ready to fit the most popular makes.

Two types are offered GB/5 and UNIBASE.

All sub-bases contain screws, line up bush and two line up pins. The line up pins and bush ensure the exact alignment of sub-base with router spindle, when fitted with the relevant collet.

GB/5 Set comprises the following

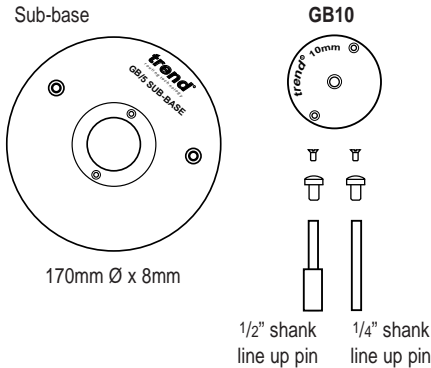

Fits following Router Models

Description	Order Ref.
Elu MOF31,77,98,131,177(E), Bosch GOF1600A & 1700ACE DeWalt DW625EK	GB/5
Makita 3612BR & 3600B Ryobi RE600N & R600N, RE601	GB/5/A
Hitachi M12V, M12SA & TR12	GB/5/D
Ryobi R500 & R502 Wadkin R500	GB/5/F
Skil 1875U1	GB/5/G
Metabo OF1612 & OFE1812, Felisatti TP246(E), R346EC	GB/5/H
Makita 3612C & 3612	GB/5/J
Bosch 1300ACE	GB/5/K
AEG OFSE2000 Casals FT2000VCE Draper R1800V Freud FT2000E	GB/5/L
Flex OFT3121VV, Portercable 7539, 7519	GB/5/M
Festo OF2000E	GB/5/N
Mafel L065E	GB/5/S*

***Please state model when ordering.**

UNIBASE comprises the following

UNIBASE

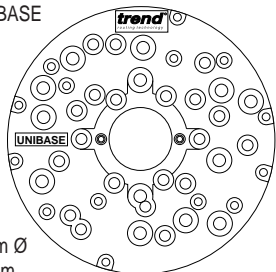

170mm Ø
x 8mm

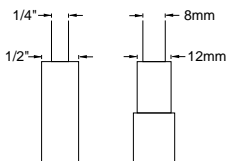
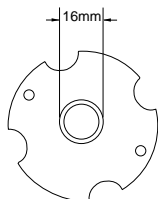

1/4" + 1/2"
shank
line up pin

8mm +
12mm shank
line up pin

Fits following Router Models

- Atlas Copco OFSE2000
- Bosch GOF 1300ACE, 1600A, 1700ACE
- Casals FT2000VCE
- DeWalt DW625EK
- Draper R1800V
- Elu MOF 31, 77, 98, 131, 177(E)
- Felisatti TP246(E), R346EC
- Festo OF2000E
- Freud FT2000E
- Hitachi MI12V, M125A, TR12
- Metabo OF1612, OFE1812
- Ryobi RE600N, R600N, RE601, R500, R502
- Skil 1875U1
- Wadkin R500

Description

Universal sub-base

Order Ref.

UNIBASE

Joining Boards

- For the best results when joining boards, ensure the ends are square and cleanly cut.

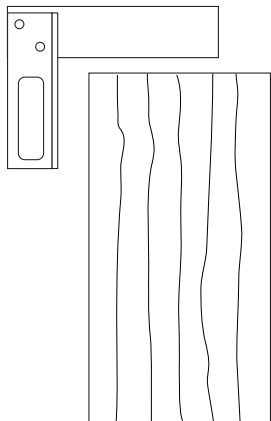

- Place the two boards to be joined with the face sides together.

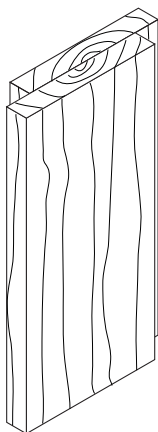

IMPORTANT!
When held horizontally ensure care is taken and that both jig and router are used at a comfortable height.

Using the Jig

- The jig can be used vertically by clamping the wood in a vice.

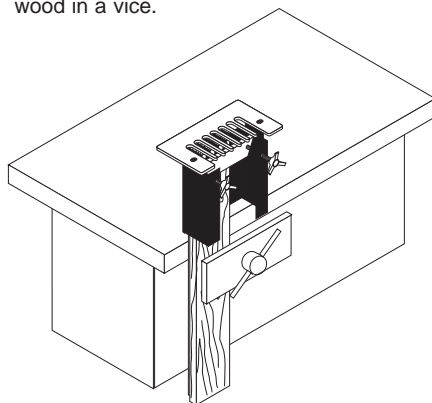

- The jig can be taken to the work place.

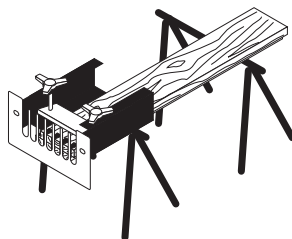

- It can be screwed to a bench. Ensure packing piece is used under timber and jig. Ensure also that the other end of the timber is supported.

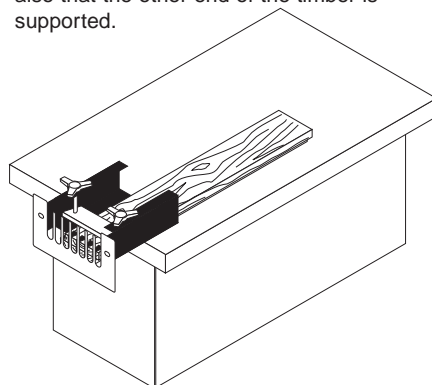

Setting-up the Jig for 8mm to 30mm thick timber

- Fit the Joinaboard jig over the ends of the two boards.

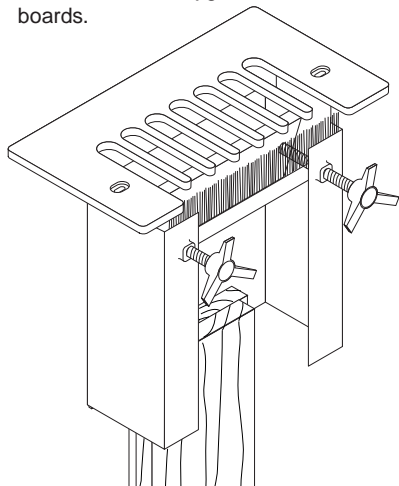

- Both boards should rest against the underside of the guide plate. Ensure both pieces of wood are firmly pressed against the left hand edge of the jig: one piece against the offset stop, the other against the side of the jig

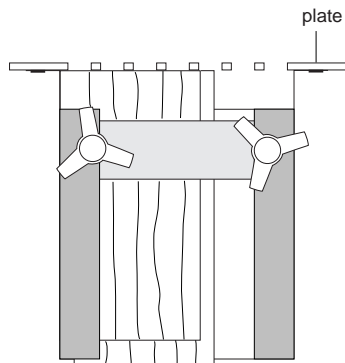
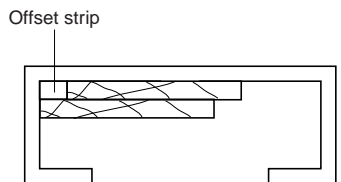

Setting-up the Jig for 31mm to 53mm thick timber

- If using timber between 31mm to 53mm, the timber will need to be cut one piece at a time.
- A 8mm thick backing piece will be needed for one of the two cuts.
- One piece of the joint will be cut with the timber against the left hand edge of the offset stop. The other piece will be cut with the timber against the left hand edge of the jig, with a 8mm packing piece placed behind the timber to support it.

1st cut

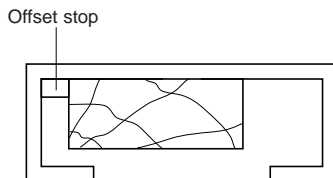

2nd cut

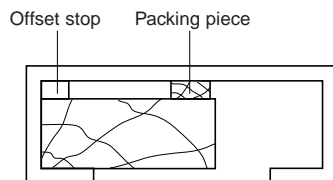

- Ensure the wood rests against the underside of the guide plate.



IMPORTANT!
For narrow timbers it may be necessary to add a packing piece to the edge of the timber. This is to ensure the dovetail is routed in the middle of the timber.

Adjusting the guide plate

- To position the dovetails slacken the hex key screws a little to allow the plate to move. Position the dovetails on the board you can see, the other board will match when you have made the cuts. The plate can be moved laterally by up to 6mm.

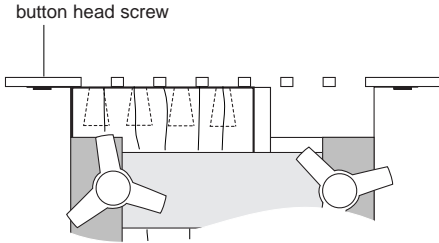

Half dovetails will match up when cut.

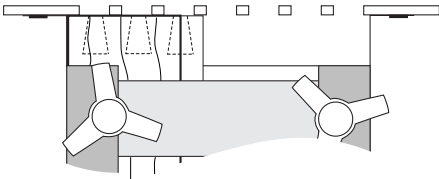

- Pay attention to the right hand side of the board and ensure no small slivers of wood will be left after cutting.

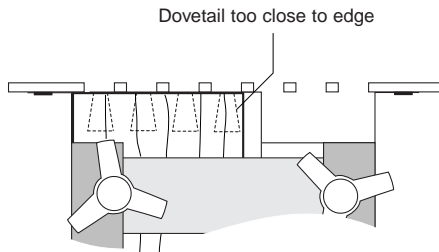

Fitting the guide bush

- Fit the 20mm guide bush to the router ensuring it is properly centred. Plunge the router to near its maximum depth using a fine height adjuster. Fit the dovetail cutter into the collet and tighten collet nut. Adjust cutter height until cutter projects approximately 30mm from the base of the router.

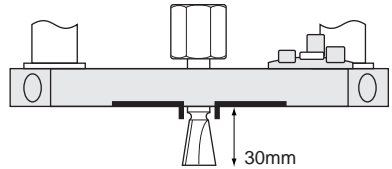

IMPORTANT!

The depth of the cutter is not so critical. Lowering it 2-3mm makes the joint tighter, raising makes it looser.

Making a Router Stand Block

- As the cutter should not be retracted into the router, a useful aid is a Router Stand Block. This is simply a piece of scrap timber with a whole large enough to take the protruding guide bush and dovetail cutter. This will allow the router to stand up safely between operations.

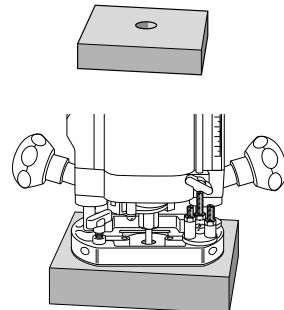

The Brush Strip

- The brush strip reduces the vigour with which chips normally come out from the cutter. The blades of the cutter pass through the brush without damage.
- The bristles will eventually wear but can be easily replaced.

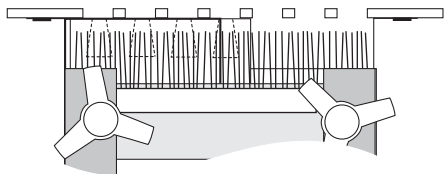

IMPORTANT!

Ensure a fine height adjuster is used and that the plunge is not retracted. If this is not done, the cutter will be pulled through the guide bush.

Cutting the boards

- Hold the router firmly against the plate and follow the fingers cutting through both boards. Ensure all dovetails and half dovetails at the edges are cut.

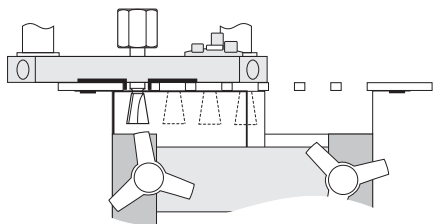

IMPORTANT!

Do not lift the router up from the plate with the cutter spinning. You may damage the plate or the cutter.

- Separate the two pieces keeping track of the face sides.

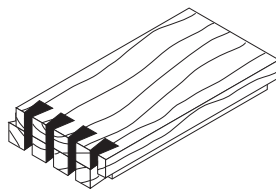

- Press the joint together. Glue as required.

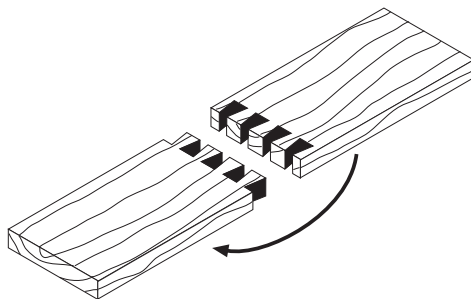

IMPORTANT!

For floor boards the glued joint must be placed over a joist or a noggin must be used.

JB/JIG - SPARE PARTS LIST			v1.0 03/2000
Item	Qty	Description	Ref.
1	1	Aluminium Guide Plate	WP-JB/01
2	1	Chassis	WP-JB/02
3	1	Clamp Bar	WP-JB/03
4	2	3 Lobe Handwheel M8 x 80mm	WP-JB/04
5	1	Rubber Pad	WP-JB/05
6	1	Glue Tape For Rubber Pad	WP-JB/06
7	2	Nut Nyloc [®] M8	WP-NUT/09
8	2	Washer 8mm x 17mm x 1.5mm	WP-WASH/15
9	1	Hex Key 4mm A/F	WP-AP/04
10	2	Nut Nyloc [®] M6	WP-NUT/15
11	1	Brush Strip	WP-JB/11
12	1	Offset Stop	WP-JB/12
13	6	Machine Screw Button M6 x 10mm Skt	WP-SCW/61
14	1	Dovetail Cutter 17.5mm Dia. x 98° (UK & Eire)	L90X1/2TC
	1	Dovetail Cutter 17.5mm Dia. x 98° (Euro)	L90X12MMTC
15	1	Guide Bush 20mm Dia.	GB20
16	2	Machine Screw Csk M5 x 10mm	WP-SCW/13
17	1	Manual	MANU/JB

JB/JIG SPARE PARTS DIAGRAM

v1.0 03/2000

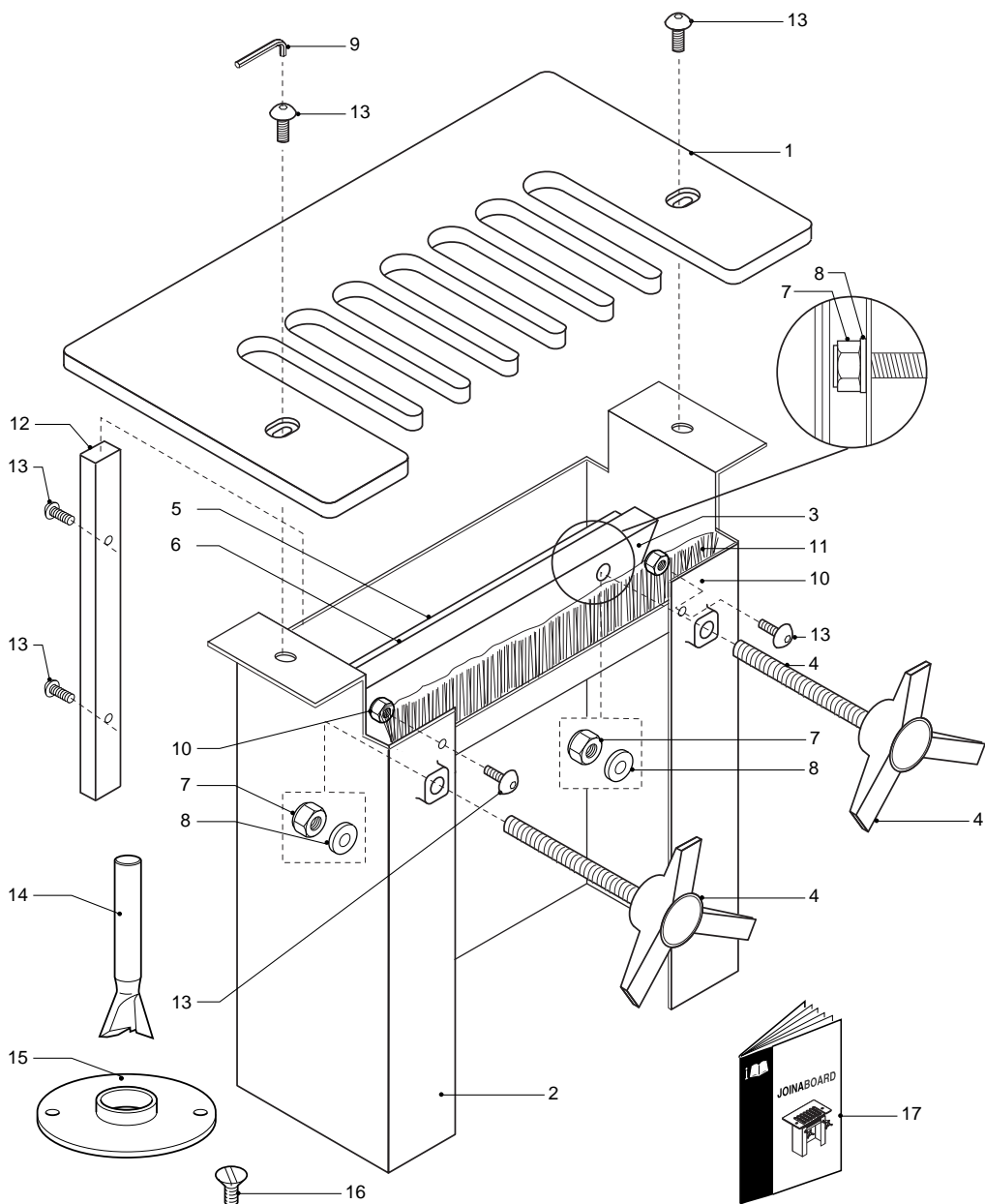

TROUBLE SHOOTING

- Tear out - this occurs when cutting across the grain and can be overcome by scribing the ends of the timber with a marking knife or gauge at the height of the cutter.

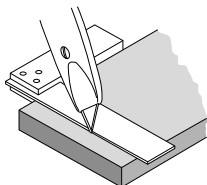

- Dovetail joint too loose - increase depth adjustment of cutter.
- Dovetail joint too tight - decrease depth adjustment of cutter.

Guarantee

- The jig carries a manufacturers guarantee in accordance with the conditions on the enclosed guarantee card.

Recycling

- Jig, accessories and packaging should be sorted for environmentally friendly recycling.