

### 90° Template Profiler

- Profilers with shank mounted bearing guides.
- For use with router mounted above or below a table when following a template.
- For profiling and rebating applications only. Not for plunge cutting/grooving.
- A 3mm maximum overlap should be left before trimming.
- For replacement collars, see Spare Parts on pages 98 - 98.
- Refs. 46/910 and 46/91 have a shorter cutter length for use on thin boards. They are ideal for template making.

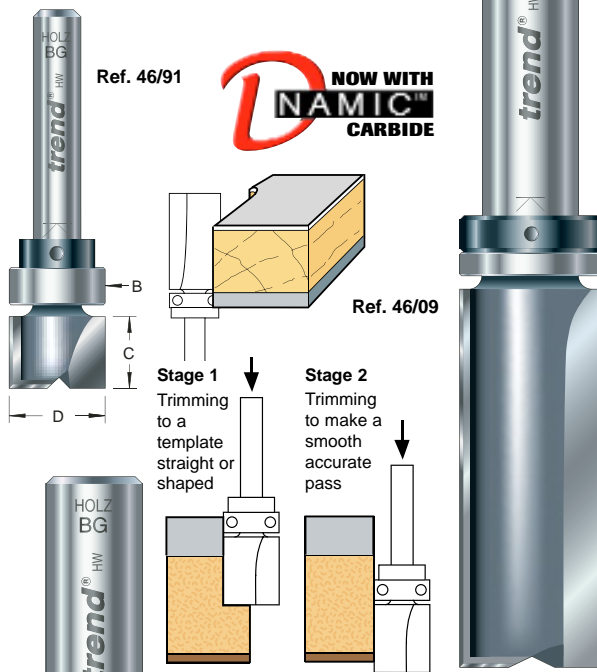

C mm	D mm	Order Ref.	TC Shank Diameter		
			1/4"	3/8"	1/2"
4	12.7	46/910	£18.00	-	-
9.5	12.7	46/91	£21.50	-	-
19.1	15.9	46/92	£26.00	-	-
25	15.9	46/90	£32.00	-	-
25	25	46/100	-	-	£40.00
25.4	12.7	46/95	£24.00	-	-
25.4	19.1	46/94	-	-	£40.50
25.4	26	46/10	-	£40.50	-
32	12.7	46/96	£25.00	-	-
45	25.4	46/101	-	-	£44.00
50	19.1	46/09	-	-	£42.50

Replacement bearings		
For 46/95, 46/91, 46/96 & 46/910	B127	£4.50
For 46/90 & 46/92	B16	£3.00
For 46/10	B26E	£10.50
For 46/09 & 46/94	B19C	£4.50
For 46/100	B25G	£9.50
For 46/101	B254G	£9.50

### 90° Double Guided Trimmer

- Ball bearings fitted to both nose and shank.
- Allows templates to be placed either on top or the bottom of the material, for ease of routing.
- Allows for irregular grained timber to be profiled more easily, by turning component other way up.

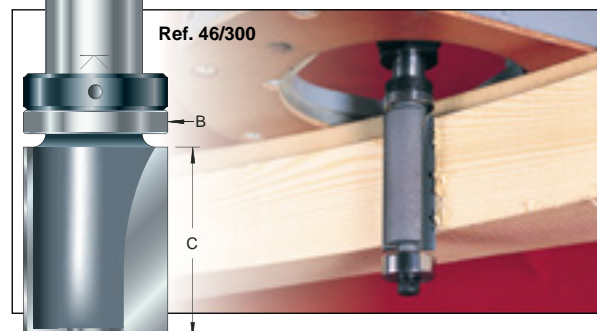

C mm	D mm	Order Ref.	TC Shank Diameter	
			12mm	1/2"
25.4	19.1	46/300	£48.00	£48.00
50	19.1	46/301	£52.50	£52.50

Replacement bearings		
For 46/300 & 46/301	B19	£3.00
- on nose	B19C	£4.50
- on shank		

### 90° Template Oversize

- Oversize profiler allows component to be routed oversize to template.
- Useful when making jigs, templates and patterns.
- Can be used for trenching operations in shallow passes.

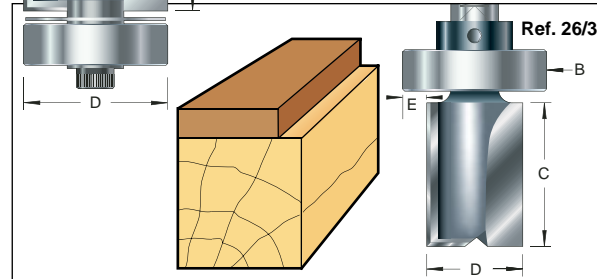

C mm	D mm	E mm	Order Ref.	TC Shank Diameter
				1/4"
19	8	2.35	26/2	£27.00
19	12.7	3.2	26/3	£29.50

Replacement bearings		
For 26/2	B127	£4.50
For 26/3	B19	£3.00

### 90° Trimmer & 'V' Groove

- Two flute.
- For trimming of laminate and solid lipping.
- 'V' groove to hide glue line.

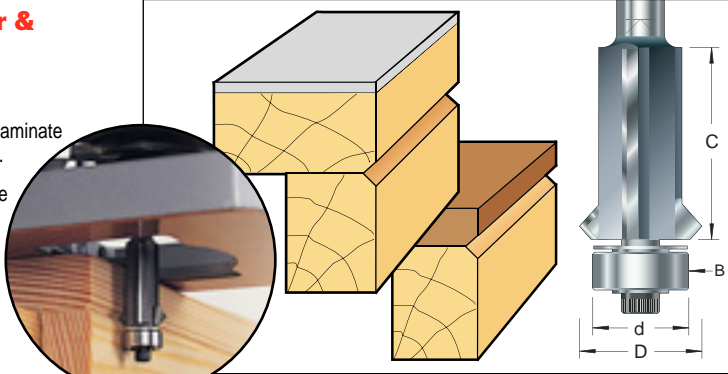

C mm	d mm	D mm	Order Ref.	TC Shank Diameter
				1/4"
25.4	12.7	16	46/85	£19.00

Spare bearing		
For 46/85	B127A	£3.00

Alternative bearing		
To reduce 'V' groove depth to 1.0mm	B14A	£7.50

### 90° Triple Flute

- Self-guiding triple flute cutters.
- Extra fine trimming and longer life.
- For trimming of laminate or plywood overlay.
- Ref. 46/82 has twin bearings for stability by increasing the bearing surface and is an industrial profiling tool for longer runs of work.

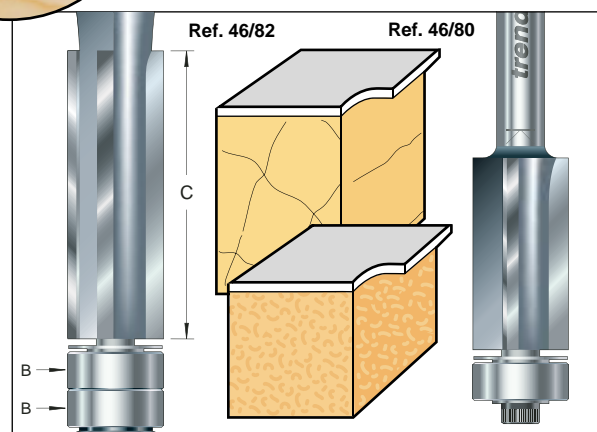

C mm	D mm	Order Ref.	TC Shank Diameter	
			1/4"	1/2"
25.4	12.7	46/80	£20.50	-
38.1	12.7	46/82	-	£43.00

Replacement bearing		
For 46/80 & 46/82	B127A	£3.00

Replacement nut		
For 46/82	ANUT/46/82	£1.00