

**Large Step Ovolo & Rounding Over**

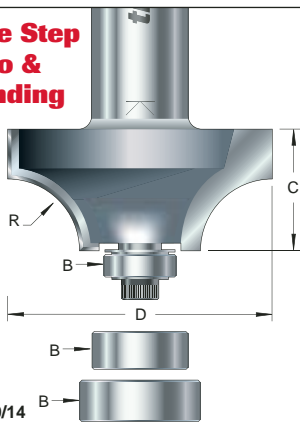

Ref. 40/14

Supplied with alternative bearings to produce a rounding over and two sizes of ovolo moulding. The smaller bearing gives a 3.2mm quirk.

<p>R=6.3mm D=28.7mm C=13mm B=9.5, 12.7 &amp; 16mm</p>		<p>R=9.5mm D=35mm C=16mm B=9.5, 12.7 &amp; 16mm</p>		<p>R=12.7mm D=44mm C=19mm B=9.5, 12.7 &amp; 16mm</p>		<p>R=15.9mm D=48mm C=22mm B=9.5, 12.7 &amp; 16mm</p>	
40/13		40/14		40/15		40/16	
1/4"	1/2"	1/4"	1/2"	1/2"	1/2"	1/2"	1/2"
£35.50	£35.50	£36.50	£36.50	£42.00	£42.00	£48.00	£48.00

**Ovolo & Rounding Over**

Ref. 7/5

Some Ovolo cutters can be used with radius cutters, to make rule joints.

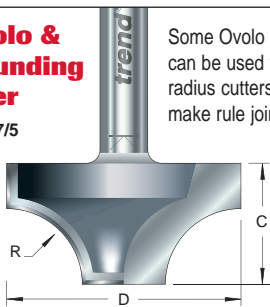

<p>R=2.5mm D=9.5mm C=9mm</p>		<p>R=3mm D=18mm C=10mm</p>		<p>R=4mm D=19mm C=11mm</p>		<p>R=5mm D=22mm C=12mm</p>		<p>R=8mm D=28mm C=15mm</p>	
7/01		7/1		7/10		7/2		7/4	
(Extra long shank - 40mm)	1/4"	1/4"	1/4"	1/4"	1/2"	1/2"	1/2"	1/4"	1/2"
£17.50	£17.50	£25.00	£25.00	£25.00	£34.50	£34.50	£34.50	£38.00	£38.00

<p>R=10mm D=31mm C=16mm</p>		<p>R=12mm D=35mm C=17mm</p>		<p>R=12.7mm D=38mm C=18mm</p>		<p>R=15mm D=41mm C=20mm</p>		<p>R=20mm D=60mm C=27mm</p>	
7/5		7/6		7/66		7/7		7/8	
1/4"	1/2"	1/4"	1/2"	1/2"	1/4"	1/2"	1/2"	1/2"	16,000
£41.50	£42.50	£42.50	£42.50	£42.00	£45.50	£45.50	£45.50	£55.00	

**Pin Guided Round Over**

Ref. 7E/3

Small solid guide pins can follow more intricate shapes in contrast to bearing guided cutters.

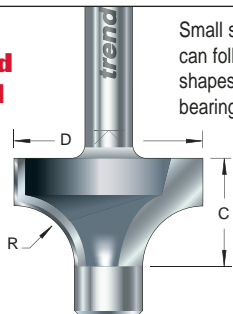

Pin dia. = 9mm

<p>R=3.2mm D=15mm C=9.5mm</p>		<p>R=4.8mm D=19mm C=11.8mm</p>	
7E/01		7E/1	
1/4"	1/4"	1/4"	1/4"
£29.50	£29.50	£30.00	£30.00

**Pin Guided Ovolo**

Ref. 7D/2

Pin dia. = 5.5mm

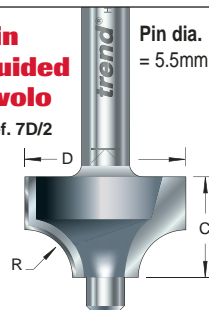

<p>R=3.2mm D=15mm C=10.2mm</p>	
7D/1	
1/4"	1/4"
£32.50	£32.50

<p>R=6.3mm D=22mm C=12.6mm</p>		<p>R=8mm D=26mm C=14.3mm</p>		<p>R=9.5mm D=29mm C=15.8mm</p>		<p>R=12.7mm D=34.4mm C=19mm</p>	
7E/2		7E/3		7E/4		7E/5	
1/4"	1/4"	1/4"	1/4"	1/4"	1/4"	1/4"	1/4"
£31.00	£31.00	£31.00	£31.00	£32.50	£32.50	£37.50	£37.50

<p>R=6.3mm D=22mm C=13.3mm</p>		<p>R=9.5mm D=29mm C=16.5mm</p>	
7D/2		7D/3	
1/4"	1/4"	1/4"	1/4"
£37.00	£37.00	£37.00	£37.00

**Shank Mounted Ball Bearing Cutters**

Ref. 17/01

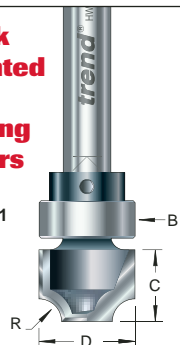

<p>R=3mm D=12.7mm C=9.5mm B=12.7mm</p>		<p>R=3mm D=19.1mm C=9.5mm B=19.1mm</p>		<p>R=5mm D=22.0mm C=12.0mm B=22.0mm</p>		<p>R=8mm D=28.6mm C=15.0mm B=28.6mm</p>	
17/01		17/1		17/2		17/4	
1/4"	1/4"	1/4"	1/4"	1/4"	1/4"	1/2"	1/2"
£26.00	£26.00	£46.50	£46.50	£36.00	£36.00	£41.50	£41.50

Drawer fronts.