

Water Slot Cutters

One Flute Helical - with normal neck, but long shank.

Ref. 50/27

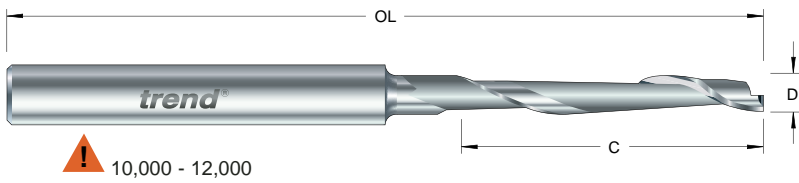

Tool Dia.	Cutting Reach		Overall length	Order Ref.	Shank Dia.	
	Cut depth	Narrow neck			HSSE	8mm
D mm	C mm	CC mm	OL mm			
4	40	-	100	50/30		£27.00
5	40	-	100	50/27		£31.50
6	40	-	100	50/31		£26.00

Two Flute Helical - for non-ferrous metals with long shank, fine finish and up-cut. The Solid Carbide (STC) cutters offer longer life.

Ref. 55/08



! HSSE 10,000 - 12,000 ! STC 12,000 - 24,000

D mm	C mm	CC mm	OL mm	Order Ref.	HSSE		
					1/4"	8mm	3/8"
5	40	-	100	50/33	-	£28.00	-
8	19	-	80	55/08	£25.00	£24.00	-
					STC		
6.3	20	-	63	S55/10	£29.00	-	-
8	20	-	63	S55/08	-	£37.50	-
9.5	25	-	63	S55/11	-	-	£39.50

Two Flute Helical - for plastic with long shank.

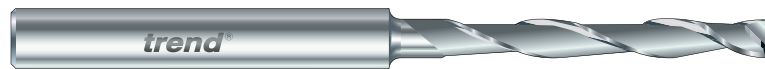

! 10,000 - 12,000

D mm	C mm	CC mm	OL mm	Order Ref.	HSSE	
					8mm	
5	40	-	100	50/32	£27.50	

Surface Milling/Routing - Threaded Shank

Straight Rotox® cutters - with M10x1.5mm internal thread, for UPVC plastics and aluminium.

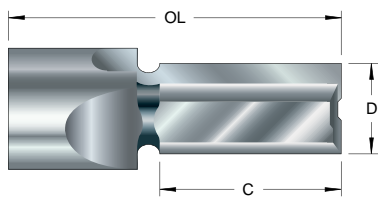

Ref. ROT 12/15

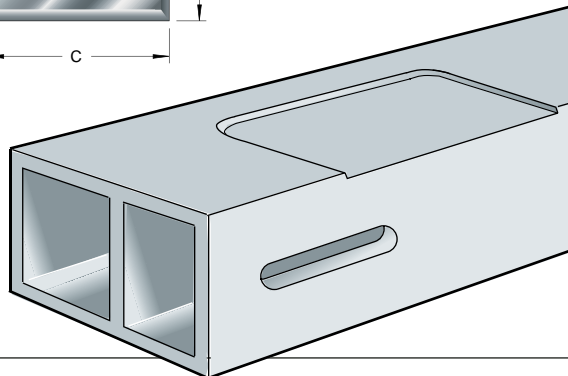

! 5,000 - 12,000

D mm	C mm	CC mm	OL mm	Order Ref.	HSS	
					M10	
					ONE FLUTE	
4	12	-	52	ROT 4/12	£40.00	
4	23	-	52	ROT 4/23	£47.50	
5	23	-	52	ROT 5/23	£42.50	
6	22	-	52	ROT 6/22	£46.00	
					TWO FLUTE	
8	26	-	47	ROT 8/26	£58.50	
9	20	-	43	ROT 9/20	£58.00	
10	30	-	50	ROT 10/30	£61.50	
12	15	-	43	ROT 12/15	£41.50	
12	23	-	43	ROT 12/23	£58.50	
12	38	-	58	ROT 12/38	£75.50	
14	30	-	51	ROT 14/30	£49.00	
16	23	-	43	ROT 16/23	£47.50	
18	23	-	43	ROT 18/23	£59.00	

Straight Two Flute

For grooving and profiling.

! 1,000 - 10,000

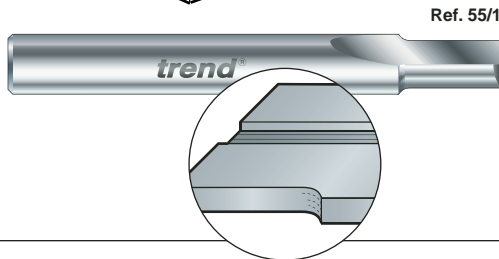

D mm	C mm	CC mm	OL mm	Order Ref.	HSS		
					1/4"	8mm	3/8"
6.3	12.7	-	65	55/1	£12.50	£12.50	-
9.5	12.7	-	65	55/2	-	£12.50	£12.50
12.7	12.7	-	65	55/3	-	£14.00	£14.50

Surface Milling - Parallel Shank

Two Flute Straight - with plain shank for aluminium and plastics. Tungsten Carbide Tipped.

! 12,000 - 24,000

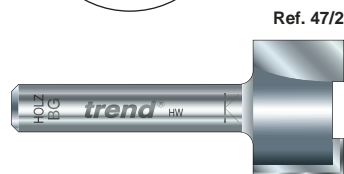

D mm	C mm	CC mm	OL mm	Order Ref.	TC	
					1/4"	8mm
18	12	-	45	47/2	£20.00	-
20	13	-	45	47/20	£25.50	£28.00

Three Flute 90° Countersink

! 1,000 - 10,000



D mm	C mm	CC mm	OL mm	Order Ref.	HSS	
					1/4"	8mm
12.7	-	-	60	49/50	£25.50	£25.50