

TEMPLATE PROFILER

Template/Profilers

- Shank mounted bearing profilers are ideal for template guidance.
- Use for rebating and trimming edges only.
- Extra care must be taken to avoid cutter breakage.

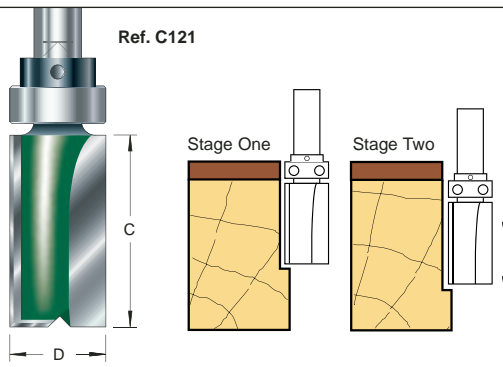

D mm	C mm	Order Ref.	TC Shank Diameter			
			1/4"	8mm	12mm	1/2"
12.7	25.4	C121	£13.50	-	-	-
16	19	C121A	-	£16.00	-	-
19.1	19.1	C165	-	-	-	£17.00
19.1	25.4	C123	£17.00	-	-	-
19.1	50	C166	-	-	£28.50	£28.50

NEW

90° Double Guided Trimmer

Allows templates to be placed either on top or the bottom of the material, for ease of routing.

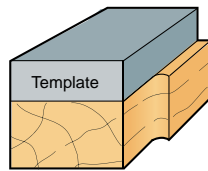
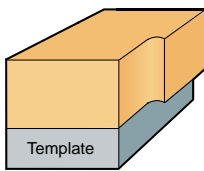
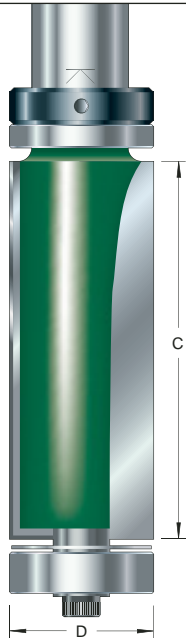
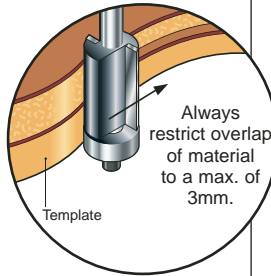

D=19.1mm
C=50.0mm
B=19.0mm

C199

1/2"

£33.00

NEW

3° Door Leading Edge

3° undercut router bit with shank mounted bearing guide for routing a leading edge on doors to allow a tight fit against jamb.

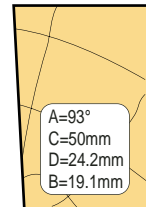
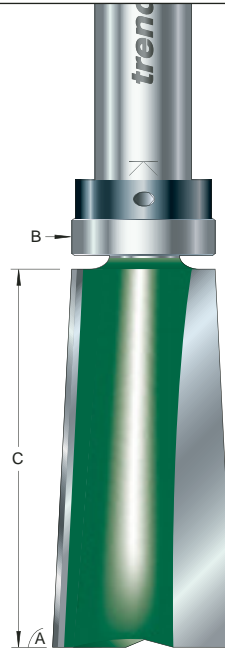
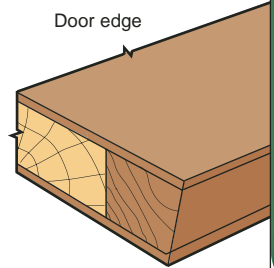

C214

1/2"

£45.00

CHAMFER CUTTERS

Chamfer 'V' Groove

Ref. C044



For veining, panelling, 'V' grooving, bevelling & chamfering.

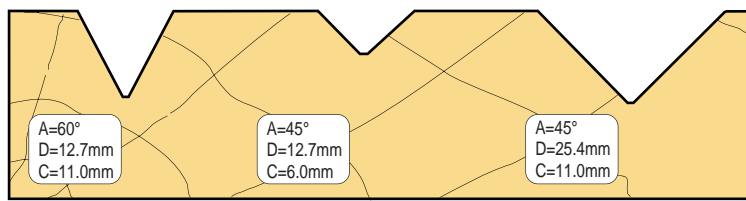

C043		
1/4"	8mm	1/2"
£11.00	£13.50	£13.00

C044		
1/4"	8mm	1/2"
£11.00	£12.50	£12.50

C045
1/4"
£19.50

Bearing Guided Bevel

Ref. C139

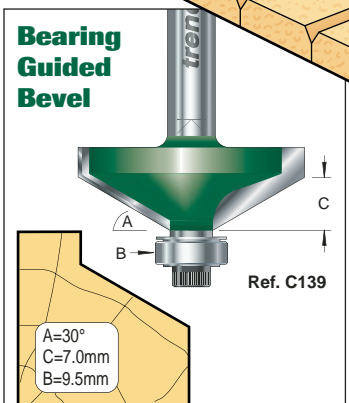

A=30°
C=7.0mm
B=9.5mm

C139

1/4"

£21.50

45° Guided Chamfer Cutters

Ref. C049

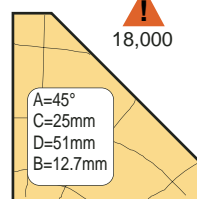
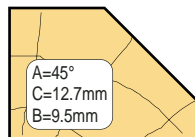
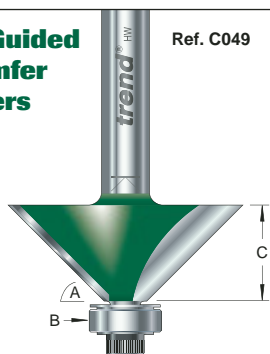

C049

1/4"	8mm	1/2"
£18.00	£18.50	£21.50

C197

1/2"
£30.00

C138

1/4"	8mm
£18.50	£18.50