

**Robert Bosch GmbH**

Power Tools Division  
70745 Leinfelden-Echterdingen  
Germany

[www.bosch-pt.com](http://www.bosch-pt.com)

1 618 C00 50R (2012.01) T / 190 XXX



1 618 C00 50R

## GCL 25 Professional



<b>de</b> Originalbetriebsanleitung	<b>cs</b> Původní návod k používání	<b>ja</b> オリジナル取扱説明書
<b>en</b> Original instructions	<b>sk</b> Pôvodný návod na použitie	<b>cn</b> 正本使用说明书
<b>fr</b> Notice originale	<b>hu</b> Eredeti használati utasítás	<b>tw</b> 正本使用說明書
<b>es</b> Manual original	<b>ru</b> Оригинальное руководство по эксплуатации	<b>ko</b> 사용 설명서 원본
<b>pt</b> Manual original	<b>uk</b> Оригінальна інструкція з експлуатації	<b>th</b> หนังสือคู่มือการใช้งานฉบับต้นแบบ
<b>it</b> Istruzioni originali	<b>ro</b> Instrucțiuni originale	<b>id</b> Petunjuk-Petunjuk untuk Penggunaan Orisinal
<b>nl</b> Oorspronkelijke gebruiksaanwijzing	<b>bg</b> Оригинална инструкция	<b>vi</b> Bảng hướng dẫn nguyên bản
<b>da</b> Original brugsanvisning	<b>sr</b> Originalno uputstvo za rad	<b>ar</b> تعليمات التشغيل الأصلية
<b>sv</b> Bruksanvisning i original	<b>sl</b> Izvirna navodila	<b>fa</b> راهنمای طرز کار اصلی
<b>no</b> Original driftsinstruks	<b>hr</b> Originalne upute za rad	
<b>fi</b> Alkuperäiset ohjeet	<b>et</b> Algupärane kasutusjuhend	
<b>el</b> Πρωτότυπο οδηγίων χρήσης	<b>lv</b> Instrukcijas oriģinālvalodā	
<b>tr</b> Orijinal işletme talimatı	<b>lt</b> Originali instrukcija	
<b>pl</b> Instrukcja oryginalna		



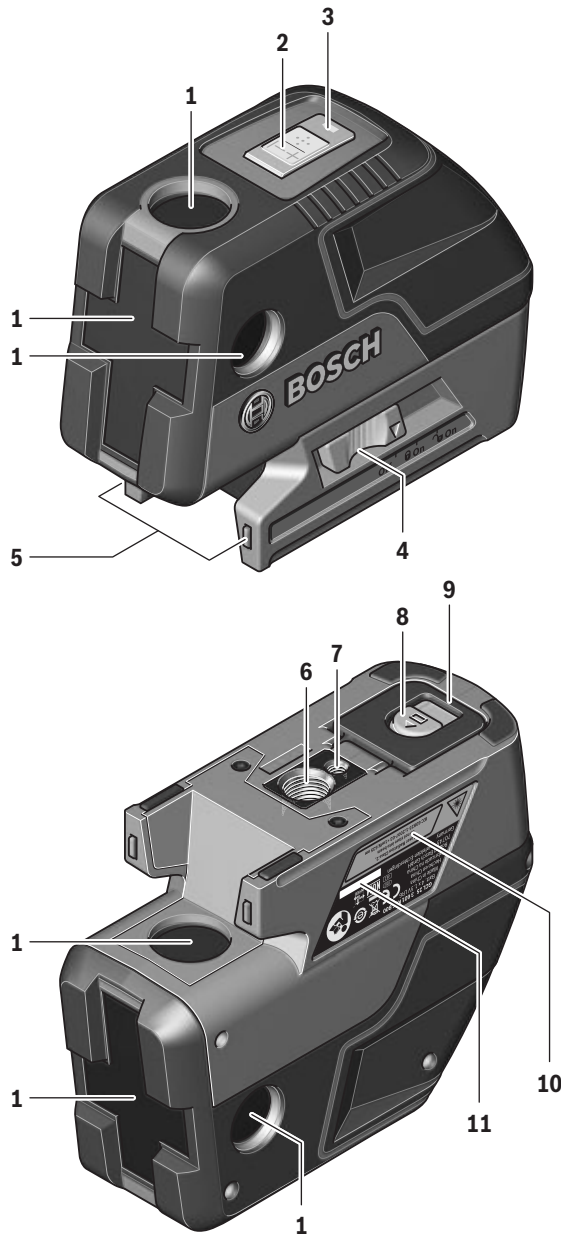

**GCL 25**

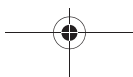



4 |

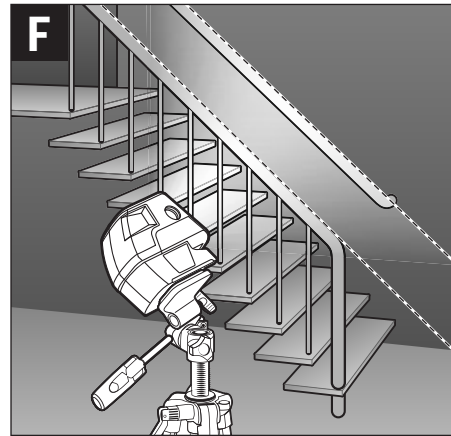
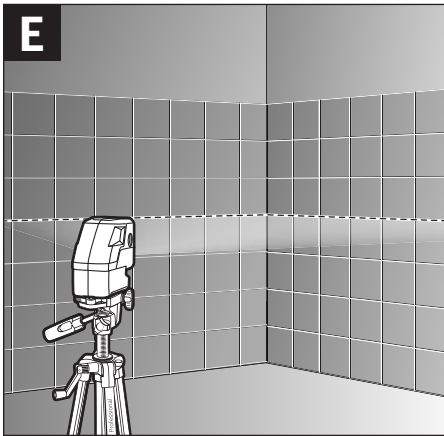
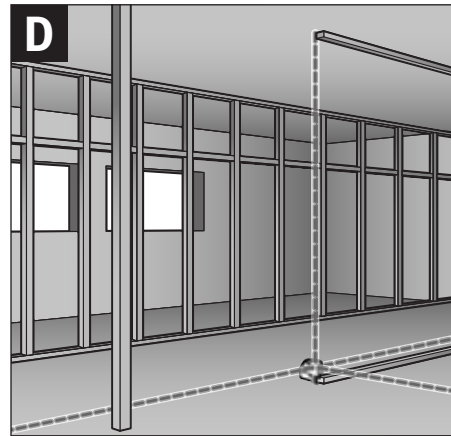
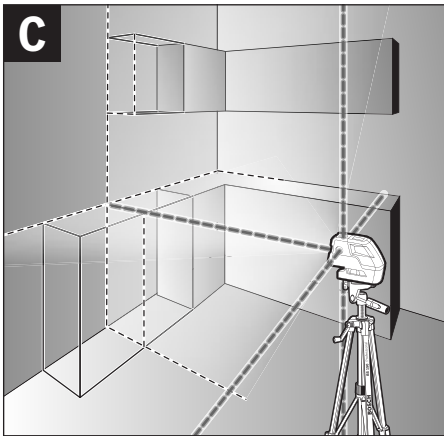
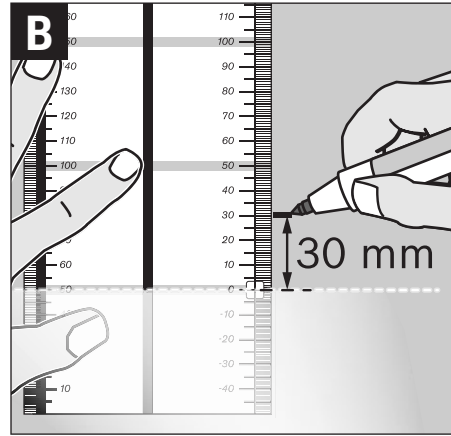
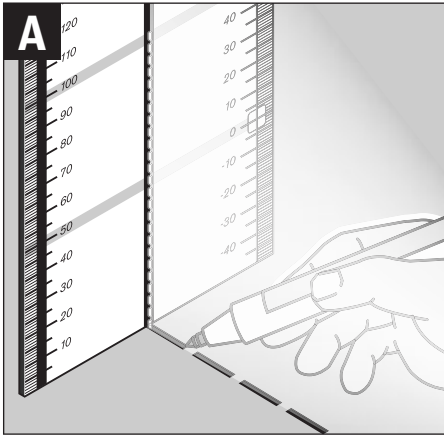

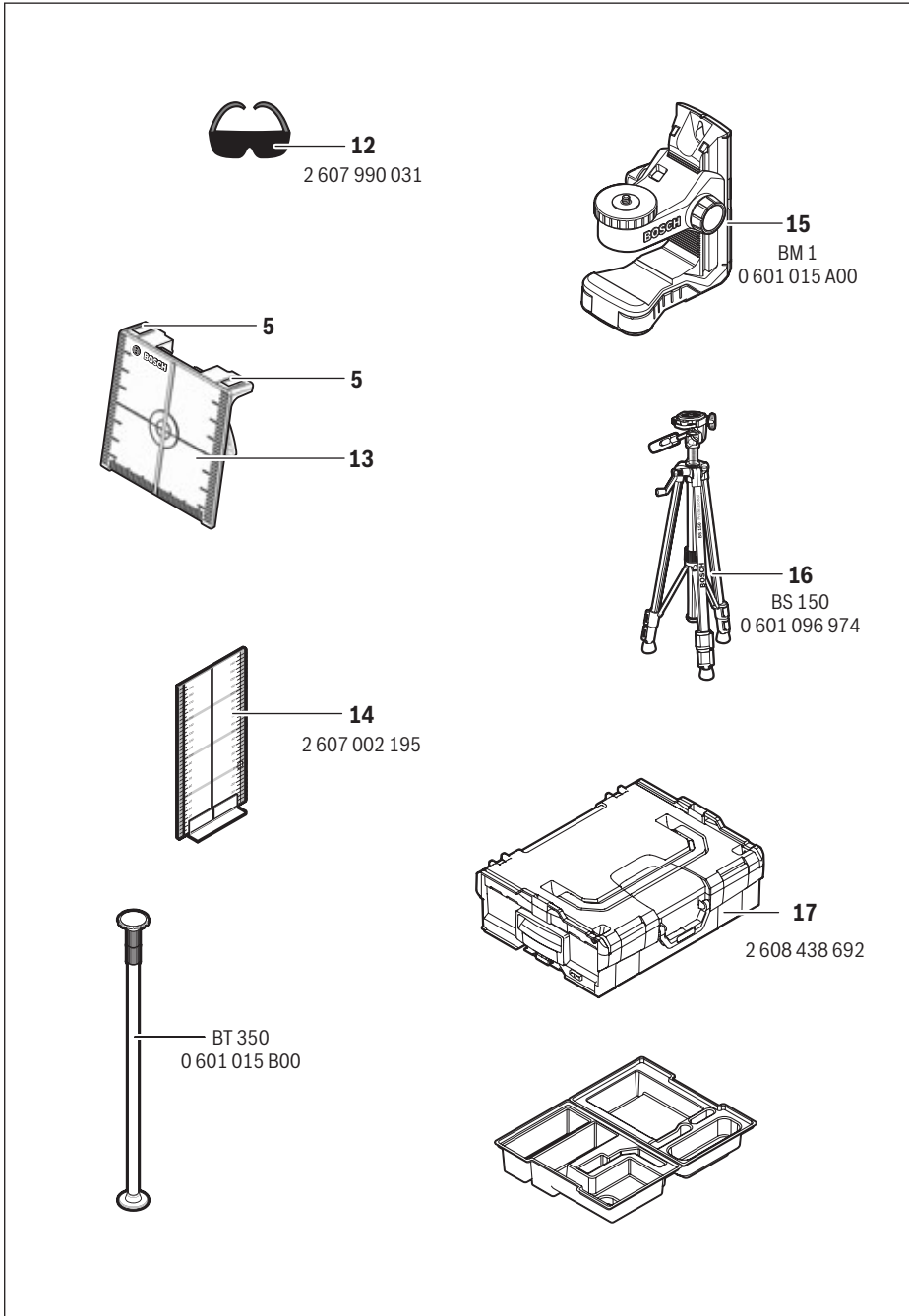

Tel. Kundenberatung: +49 (1803) 33 57 99  
 (Festnetzpreis 9 ct/min, höchstens 42 ct/min aus Mobilfunknetzen)  
 Fax: +49 (711) 7 58 19 30  
 E-Mail: kundenberatung.ew@de.bosch.com

#### Österreich

Tel.: +43 (01) 7 97 22 20 10  
 Fax: +43 (01) 7 97 22 20 11  
 E-Mail: service.elektrowerkzeuge@at.bosch.com

#### Schweiz

Tel.: +41 (044) 8 47 15 11  
 Fax: +41 (044) 8 47 15 51

#### Luxemburg

Tel.: +32 2 588 0589  
 Fax: +32 2 588 0595  
 E-Mail: outillage.gereedschap@be.bosch.com

#### Entsorgung

Messwerkzeuge, Zubehör und Verpackungen sollen einer umweltgerechten Wiederverwertung zugeführt werden.  
 Werfen Sie Messwerkzeuge und Akkus/Batterien nicht in den Hausmüll!

#### Nur für EU-Länder:



Gemäß der europäischen Richtlinie 2002/96/EG müssen nicht mehr gebrauchsfähige Messwerkzeuge und gemäß der europäischen Richtlinie 2006/66/EG müssen defekte oder verbrauchte Akkus/Batterien getrennt gesammelt und einer umweltgerechten Wiederverwendung zugeführt werden.

Nicht mehr gebrauchsfähige Akkus/Batterien können direkt abgegeben werden bei:

#### Deutschland

Recyclingzentrum Elektrowerkzeuge  
 Osteroder Landstraße 3  
 37589 Kalefeld

#### Schweiz

Batrec AG  
 3752 Wimmis BE

Änderungen vorbehalten.

## English

### Safety Notes



**Working safely with the measuring tool is possible only when the operating and safety information are read completely and the instructions contained therein are strictly followed. Never make warning labels on the measuring tool unrecognisable. SAVE THESE INSTRUCTIONS.**

- ▶ **Caution – The use of other operating or adjusting equipment or the application of other processing methods than those mentioned here, can lead to dangerous radiation exposure.**
- ▶ **The measuring tool is provided with a warning label in English (marked with number 10 in the representation of the measuring tool on the graphics page).**



- ▶ **Do not direct the laser beam at persons or animals and do not stare into the laser beam yourself.** This measuring tool produces laser class 2 laser radiation according to IEC 60825-1. This can lead to persons being blinded.
- ▶ **Do not use the laser viewing glasses as safety goggles.** The laser viewing glasses are used for improved visualisation of the laser beam, but they do not protect against laser radiation.
- ▶ **Do not use the laser viewing glasses as sun glasses or in traffic.** The laser viewing glasses do not afford complete UV protection and reduce colour perception.
- ▶ **Have the measuring tool repaired only through qualified specialists using original spare parts.** This ensures that the safety of the measuring tool is maintained.
- ▶ **Do not allow children to use the laser measuring tool without supervision.** They could unintentionally blind other persons or themselves.
- ▶ **Do not operate the measuring tool in explosive environments, such as in the presence of flammable liquids, gases or dusts.** Sparks can be created in the measuring tool which may ignite the dust or fumes.



**Keep the measuring tool and the laser target plate 13 away from cardiac pacemakers.** The magnets of the measuring tool and laser target plate generate a field that can impair the function of cardiac pacemakers.

- ▶ **Keep the measuring tool and the laser target plate 13 away from magnetic data medium and magnetically-sensitive equipment.** The effect of the magnets of the measuring tool and laser target plate can lead to irreversible data loss.

## Product Description and Specifications

Please unfold the fold-out page with the representation of the measuring tool and leave it unfolded while reading the operating instructions.

### Intended Use

The measuring tool is intended for determining and checking horizontal and vertical lines as well as plumb points.

## 12 | English

**Product Features**

The numbering of the product features shown refers to the illustration of the measuring tool on the graphic page.

- 1 Exit opening for laser beam
- 2 Operating mode button
- 3 Battery low indicator
- 4 On/Off switch
- 5 Magnets
- 6 Tripod mount 5/8"
- 7 Tripod mount 1/4"
- 8 Latch of battery lid
- 9 Battery lid
- 10 Laser warning label
- 11 Serial number
- 12 Laser viewing glasses\*
- 13 Laser target plate
- 14 Measuring plate with stand\*
- 15 Universal holder\*
- 16 Tripod\*
- 17 Case

\*The accessories illustrated or described are not included as standard delivery.

**Technical Data**

Point and line laser	GCL 25
Article number	3 601 K66 B00
Working range <sup>1)</sup>	
– Laser lines	10 m
– Horizontal point beams	30 m
– Point beam, upward	10 m
– Point beam, downward	5 m
Levelling accuracy	
– Laser lines and horizontal point beams	±0.3 mm/m
– Vertical point beams	±0.5 mm/m
Self-levelling range, typically	±4°
Levelling duration, typically	< 4 s
Operating temperature	–10 °C ... +50 °C
Storage temperature	–20 °C ... +70 °C
Relative air humidity, max.	90 %
Laser class	2
Laser type	635 nm, < 1 mW
C <sub>6</sub>	1
Tripod mount	1/4", 5/8"
Batteries	4 x 1.5 V LR06 (AA)

1) The working range can be decreased by unfavourable environmental conditions (e.g. direct sun irradiation).

Please observe the article number on the type plate of your measuring tool. The trade names of the individual measuring tools may vary.

The measuring tool can be clearly identified with the serial number **11** on the type plate.

**Point and line laser****GCL 25**

Battery life for the operating modes	
– Cross and point-line operation	12 h
– 5-point operation	24 h
– Line operation	30 h
Weight according to EPTA-Procedure 01/2003	0.6 kg
Dimensions (length x width x height)	155 x 56 x 118 mm
Degree of protection	IP 54 (dust and splash water protected)

1) The working range can be decreased by unfavourable environmental conditions (e.g. direct sun irradiation).

Please observe the article number on the type plate of your measuring tool. The trade names of the individual measuring tools may vary.

The measuring tool can be clearly identified with the serial number **11** on the type plate.

**Assembly****Inserting/Replacing the Battery**

Alkali-manganese batteries are recommended for the measuring tool.

To open the battery lid **9**, slide the latch **8** in the direction of the arrow and fold the battery lid up. Insert the batteries.

When inserting, pay attention to the correct polarity according to the representation on the inside of the battery lid.

When the batteries are low, the battery low indicator **3** flashes red. Additionally, the laser beams flash for approx. 5 s every 10 minutes. When the flashing initially begins, the measuring tool can be operated for approx. 1 more hour. When the batteries become empty, the laser beams flash one more time directly prior to the automatic shut-off.

Always replace all batteries at the same time. Only use batteries from one brand and with the identical capacity.

► **Remove the batteries from the measuring tool when not using it for extended periods.** When storing for extended periods, the batteries can corrode and discharge themselves.

**Operation****Initial Operation**

► **Protect the measuring tool against moisture and direct sun light.**

► **Do not subject the measuring tool to extreme temperatures or variations in temperature.** As an example, do not leave it in vehicles for long time. In case of large variations in temperature, allow the measuring tool to adjust to the ambient temperature before putting it into operation. In case of extreme temperatures or variations in temperature, the accuracy of the measuring tool can be impaired.

► **Avoid heavy impact or falling of the measuring tool.**

After heavy exterior impact on the measuring tool, an accuracy check should always be carried out before continuing to work (see "Levelling Accuracy").

- ▶ **Switch the measuring tool off during transport.** When switching off, the levelling unit, which can be damaged in case of intense movement, is locked.

### Switching On and Off

To **switch on** the measuring tool, slide the On/Off switch **4** to the “**on**” position (when working without automatic levelling) or to the “**on**” position (when working with automatic levelling). Immediately after switching on, the measuring tool sends laser beams out of the exit openings **1**.

- ▶ **Do not point the laser beam at persons or animals and do not look into the laser beam yourself, not even from a large distance.**

To **switch off** the measuring tool, slide the On/Off switch **4** to the “**off**” position. When switching off, the levelling unit is locked.

### Deactivating the Automatic Shut-off

When no button on the measuring tool is pressed for approx. 30 minutes, the measuring tool automatically switches off to save the batteries.

To switch on the measuring tool after automatic shut-off, either slide the On/Off switch **4** to the “**off**” position and then switch the measuring tool on again or press the operating mode button **2** once.

To deactivate the automatic shut-off, keep the operating mode button **2** pressed for at least 3 s (while the measuring tool is switched on). Deactivation of the automatic shut-off is confirmed by brief flashing of the laser beams.

- ▶ **Do not leave the switched on measuring tool unattended and switch the measuring tool off after use.** Other persons could be blinded by the laser beam.

To activate the automatic shut-off, switch the measuring tool off and then on again.

### Operating Modes

The measuring tool has several operating modes between which you can switch at any time:

- Cross and point-line operation: The measuring tool generates a horizontal and a vertical laser line facing toward the front as well as a vertical point beam each facing upward and downward, and a horizontal point beam each facing toward the front and to both sides.
- 5-point operation: The measuring tool generates a vertical point beam each facing upward and downward, as well as a horizontal point beam each facing toward the front and to both sides.
- Horizontal line operation: The measuring tool generates a horizontal laser line facing frontward.
- Vertical line operation: The measuring tool generates a vertical laser line facing frontward.

All point beams run at a 90° angle to each other; the laser lines also cross each other at a 90° angle.

After switching on, the measuring tool is in cross-line and point-line operation. To change the operating mode, press the operating mode button **2**.

All operating modes can be selected both with and without automatic levelling.

### Automatic Levelling

#### Working with Automatic Levelling (see figures C–E)

Position the measuring tool on a level and firm support, attach it to the holder **15** or to the tripod **16**.

When working with automatic levelling, push the On/Off switch **4** to the “**on**” position.

After switching on, the automatic levelling function automatically compensates irregularities within the self-levelling range of  $\pm 4^\circ$ . The levelling is finished as soon as the laser points or laser lines do not move any more.

If the automatic levelling function is not possible, e.g. because the surface on which the measuring tool stands deviates by more than  $4^\circ$  from the horizontal plane, the laser beams flash. This alarm is deactivated within 10 s after switching on, in order to allow adjustment of the measuring tool.

Set up the measuring tool in level position and wait for the self-levelling to take place. As soon as the measuring tool is within the self-levelling range of  $\pm 4^\circ$ , the laser beams light up continuously.

In case of ground vibrations or position changes during operation, the measuring tool is automatically levelled in again. To avoid errors by moving the measuring tool, check the position of the laser beams with regard to the reference points upon re-levelling.

#### Working without Automatic Levelling (see figure F)

For work without automatic levelling, push the On/Off switch **4** to the “**on**” position. When the automatic levelling is switched off, the laser lines flash continuously.

When automatic levelling is switched off, you can hold the measuring tool freely in your hand or place it on an inclined surface. The laser beams no longer necessarily run vertical to each other.

### Levelling Accuracy

#### Influences on Accuracy

The ambient temperature has the greatest influence. Especially temperature differences occurring from the ground upward can divert the laser beam.

As thermal fluctuation is largest close to the ground, the measuring tool, if possible, should be mounted on a commercially available tripod and placed in the centre of the working area.

Apart from exterior influences, device-specific influences (such as heavy impact or falling down) can lead to deviations. Therefore, check the accuracy of the measuring tool each time before starting your work.

When the accuracy of the horizontal point beams is within the maximum allowed deviation, then the accuracy of the vertical point beams and the laser lines is thus also checked.

Should the measuring tool exceed the maximum deviation during one of the tests, please have it repaired by a Bosch after-sales service.

14 | English

**Checking the Horizontal Levelling Accuracy of the Lateral Axis**

A free measuring distance of 20 m on a firm surface in front of a wall is required for the check.

- Mount the measuring tool onto the holder or a tripod, or place it on a firm and level surface at a distance of 20 m to the wall. Switch the measuring tool on and select 5-point operation.

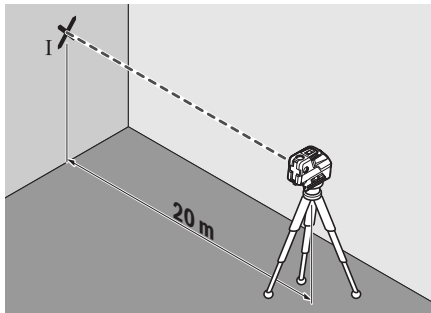

- Direct one of the two lateral laser beams, that run alongside the lateral axis of the measuring tool, at the wall. Allow the measuring tool to level in. Mark the centre of the laser beam on the wall (point I).

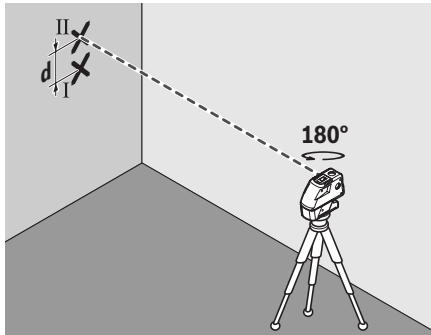

- Rotate the measuring tool by approx. 180° without changing its height. Allow it to level in and mark the centre point of the other lateral laser beam on the wall (point II). Take care that point II is as vertical as possible above or below point I.
- The difference **d** of both marked points I and II on the wall results in the actual height deviation of the measuring tool alongside the lateral axis.

On the measuring distance of  $2 \times 20 \text{ m} = 40 \text{ m}$ , the maximum allowable deviation is:  
 $40 \text{ m} \times \pm 0.3 \text{ mm/m} = \pm 12 \text{ mm}$ .  
 Thus, the difference **d** between points I and II may not exceed 12 mm (max.).

**Checking the Horizontal Levelling Accuracy of the Longitudinal Axis**

A free measuring distance of 20 m on a firm surface between two walls A and B is required for the check.

- Mount the measuring tool onto the holder or a tripod, or place it on a firm and level surface close to wall A. Switch the measuring tool on and select 5-point operation.

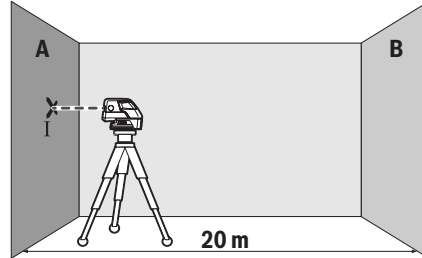

- Direct the horizontal laser beam, which runs parallel to the longitudinal axis of the measuring tool, at the close wall A. Allow the measuring tool to level in. Mark the centre of the laser beam on the wall (point I).

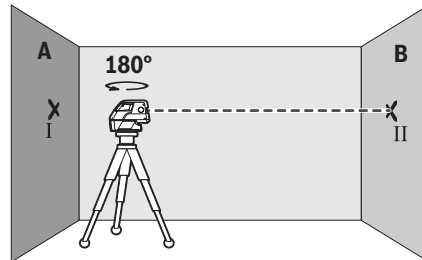

- Turn the measuring tool around by 180°, allow it to level in and mark the centre point of the laser beam on the opposite wall B (point II).
- Without turning the measuring tool, position it close to wall B. Switch the measuring tool on and allow it to level in.

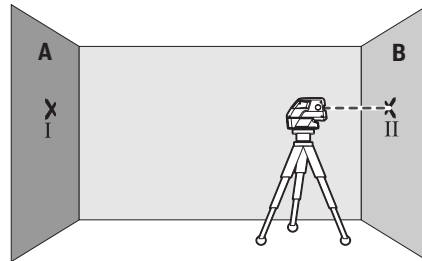

- Align the height of the measuring tool (using the tripod or by underlaying, if required) in such a manner that the centre point of the laser beam is projected exactly against the previously marked point II on wall B.



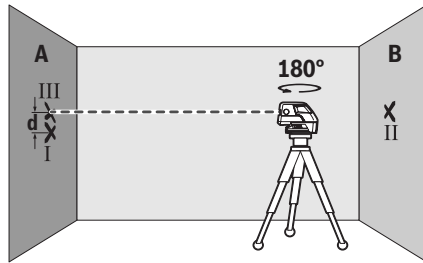

- Rotate the measuring tool by 180° without changing the height. Allow it to level in and mark the centre point of the laser beam on wall A (point III). Take care that point III is as vertical as possible above or below point I.
- The difference **d** of both marked points I and III on wall A results in the actual height deviation of the measuring tool alongside the Longitudinal axis.

On the measuring distance of  $2 \times 20 \text{ m} = 40 \text{ m}$ , the maximum allowable deviation is:  $40 \text{ m} \times \pm 0.3 \text{ mm/m} = \pm 12 \text{ mm}$ . Thus, the difference **d** between points I and III may not exceed 12 mm (max.).

### Working Advice

- ▶ **For marking, always use only the centre of the laser point or the laser line.** The size of the laser point as well as the width of the laser line change with distance.

### Working with the Tripod (Accessory)

A tripod offers a stable, height-adjustable measuring support. Position the measuring tool with the 1/4" tripod mount **7** onto the thread of the tripod **16** or a commercially available camera tripod. For fastening to a commercially available construction tripod, use the 5/8" tripod mount **6**. Tighten the measuring tool with the tripod mounting stud.

Adjust the tripod roughly before switching on the measuring tool.

### Fastening with the Universal Holder (Accessory)

With the universal holder **15**, you can fasten the measuring tool, e. g., to vertical surfaces, pipes or magnetizable materials. The universal holder is also suitable for use as a ground tripod and makes the height adjustment of the measuring tool easier.

Adjust the universal holder roughly before **15** switching on the measuring tool.

### Working with the Measuring Plate (Accessory) (see figures A – B)

With the measuring plate **14**, it is possible to project the laser mark onto the floor or the laser height onto a wall.

With the zero field and the scale, the offset or drop to the required height can be measured and projected at another location. This eliminates the necessity of precisely adjusting the measuring tool to the height to be projected.

The measuring plate **14** has a reflective coating that enhances the visibility of the laser beam at greater distances or in intense sunlight. The brightness intensification can be seen only when viewing, parallel to the laser beam, onto the measuring plate.

### Working with the Laser Target Plate

The laser target plate **13** increases the visibility of the laser beam under unfavourable conditions and at large distances. The reflective part of the laser target plate **13** improves the visibility of the laser line. Thanks to the transparent part, the laser line is also visible from the back side of the laser target plate.

### Laser Viewing Glasses (Accessory)

The laser viewing glasses filter out the ambient light. This makes the red light of the laser appear brighter for the eyes.

- ▶ **Do not use the laser viewing glasses as safety goggles.** The laser viewing glasses are used for improved visualisation of the laser beam, but they do not protect against laser radiation.
- ▶ **Do not use the laser viewing glasses as sun glasses or in traffic.** The laser viewing glasses do not afford complete UV protection and reduce colour perception.

### Work Examples (see figures C – F)

Applicational examples for the measuring tool can be found on the graphics pages.

Always position the measuring tool close to the surface or edge subject to checking, and allow it to level in prior to each measurement.

Always measure the distances between laser beam or laser line and a surface or edge at two points as far as possible away from each other (e. g. with the measurement plate **14**).

## Maintenance and Service

### Maintenance and Cleaning

Store and transport the measuring tool only in the supplied case.

Keep the measuring tool clean at all times.

Do not immerse the measuring tool in water or other fluids.

Wipe off debris using a moist and soft cloth. Do not use any cleaning agents or solvents.

Regularly clean the surfaces at the exit opening of the laser in particular, and pay attention to any fluff of fibres.

If the measuring tool should fail despite the care taken in manufacturing and testing procedures, repair should be carried out by an authorised after-sales service centre for Bosch power tools. Do not open the measuring tool yourself.

In all correspondence and spare parts orders, please always include the 10-digit article number given on the type plate of the measuring tool.

For repairs, only send in the measuring tool in the case.

### After-sales Service and Customer Assistance

Our after-sales service responds to your questions concerning maintenance and repair of your product as well as spare parts. Exploded views and information on spare parts can also be found under:

**www.bosch-pt.com**

Our customer service representatives can answer your questions concerning possible applications and adjustment of products and accessories.

## 16 | English

**Great Britain**

Robert Bosch Ltd. (B.S.C.)  
 P.O. Box 98  
 Broadwater Park  
 North Orbital Road  
 Denham  
 Uxbridge  
 UB 9 5HJ  
 Tel. Service: +44 (0844) 736 0109  
 Fax: +44 (0844) 736 0146  
 E-Mail: boschservicecentre@bosch.com

**Ireland**

Origo Ltd.  
 Unit 23 Magna Drive  
 Magna Business Park  
 City West  
 Dublin 24  
 Tel. Service: +353 (01) 4 66 67 00  
 Fax: +353 (01) 4 66 68 88

**Australia, New Zealand and Pacific Islands**

Robert Bosch Australia Pty. Ltd.  
 Power Tools  
 Locked Bag 66  
 Clayton South VIC 3169  
 Customer Contact Center  
 Inside Australia:  
 Phone: +61 (01300) 307 044  
 Fax: +61 (01300) 307 045  
 Inside New Zealand:  
 Phone: +64 (0800) 543 353  
 Fax: +64 (0800) 428 570  
 Outside AU and NZ:  
 Phone: +61 (03) 9541 5555  
 www.bosch.com.au

**Republic of South Africa****Customer service**

Hotline: +27 (011) 6 51 96 00

**Gauteng – BSC Service Centre**

35 Roper Street, New Centre  
 Johannesburg  
 Tel.: +27 (011) 4 93 93 75  
 Fax: +27 (011) 4 93 01 26  
 E-Mail: bsctools@icon.co.za

**KZN – BSC Service Centre**

Unit E, Almar Centre  
 143 Crompton Street  
 Pinetown  
 Tel.: +27 (031) 7 01 21 20  
 Fax: +27 (031) 7 01 24 46  
 E-Mail: bsc.dur@za.bosch.com

**Western Cape – BSC Service Centre**

Democracy Way, Prosperity Park  
 Milnerton  
 Tel.: +27 (021) 5 51 25 77  
 Fax: +27 (021) 5 51 32 23  
 E-Mail: bsc@zsd.co.za

**Bosch Headquarters**

Midrand, Gauteng  
 Tel.: +27 (011) 6 51 96 00  
 Fax: +27 (011) 6 51 98 80  
 E-Mail: rbsa-hq.pts@za.bosch.com

**People's Republic of China****China Mainland**

Bosch Power Tools (China) Co., Ltd.  
 567, Bin Kang Road  
 Bin Jiang District 310052  
 Hangzhou, P. R. China  
 Service Hotline: 400 826 8484  
 Fax: +86 571 8777 4502  
 E-Mail: contact.ptcn@cn.bosch.com  
 www.bosch-pt.com.cn

**HK and Macau Special Administrative Regions**

Robert Bosch Hong Kong Co. Ltd.  
 21st Floor, 625 King's Road  
 North Point, Hong Kong  
 Customer Service Hotline: +852 2101 0235  
 Fax: +852 2590 9762  
 E-Mail: info@hk.bosch.com  
 www.bosch-pt.com.hk

**Indonesia**

PT. Multi Mayaka  
 Kawasan Industri Pulogadung  
 Jalan Rawa Gelam III No. 2  
 Jakarta 13930  
 Indonesia  
 Tel.: +62 (21) 46 83 25 22  
 Fax: +62 (21) 46 82 86 45/68 23  
 E-Mail: sales@multimayaka.co.id  
 www.bosch-pt.co.id

**Philippines**

Robert Bosch, Inc.  
 28th Floor Fort Legend Towers,  
 3rd Avenue corner 31st Street,  
 Fort Bonifacio Global City,  
 1634 Taguig City, Philippines  
 Tel.: +63 (2) 870 3871  
 Fax: +63 (2) 870 3870  
 matheus.contiero@ph.bosch.com  
 www.bosch-pt.com.ph

Bosch Service Center:  
 9725-27 Kamagong Street  
 San Antonio Village  
 Makati City, Philippines  
 Tel.: +63 (2) 899 9091  
 Fax: +63 (2) 897 6432  
 rosalia.dagdagan@ph.bosch.com