

Robert Bosch GmbH
Power Tools Division
70745 Leinfelden-Echterdingen
Germany

www.bosch-pt.com

1 609 92A 04K (2012.11) PS / 333 UNI



1 609 92A 04K

GCM 8 SJL Professional

 **BOSCH**

de Originalbetriebsanleitung	el Πρωτότυπο οδηγιών χρήσης	sr Originalno uputstvo za rad
en Original instructions	tr Orijinal işletme talimatı	sl Izvirna navodila
fr Notice originale	pl Instrukcja oryginalna	hr Originalne upute za rad
es Manual original	cs Původní návod k používání	et Algupärane kasutusjuhend
pt Manual original	sk Pôvodný návod na použitie	lv Instrukcijas oriģinālvalodā
it Istruzioni originali	hu Eredeti használati utasítás	lt Originali instrukcija
nl Oorspronkelijke gebruiksaanwijzing	ru Оригинальное руководство по эксплуатации	ar تعليمات التشغيل الأصلية
da Original brugsanvisning	uk Оригінальна інструкція з експлуатації	fa دفترچه راهنمای اصلی
sv Bruksanvisning i original	ro Instrucțiuni originale	
no Original driftsinstruks	bg Оригинална инструкция	
fi Alkuperäiset ohjeet		





GCM 8 SJL

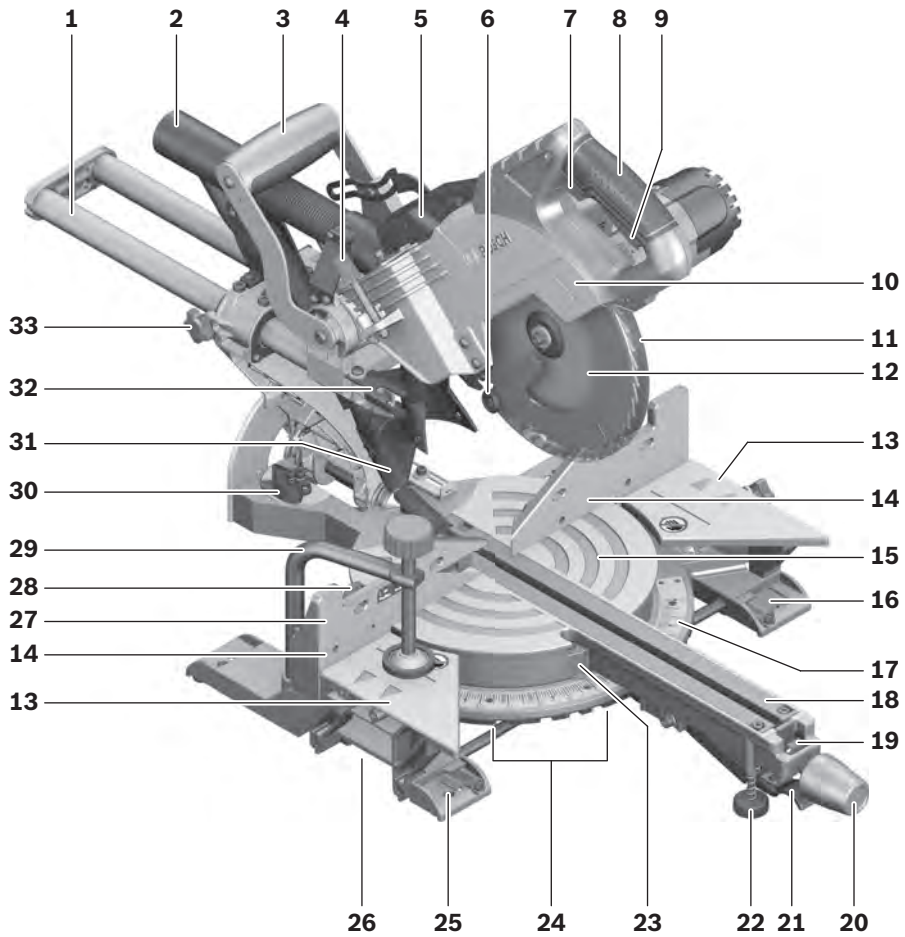
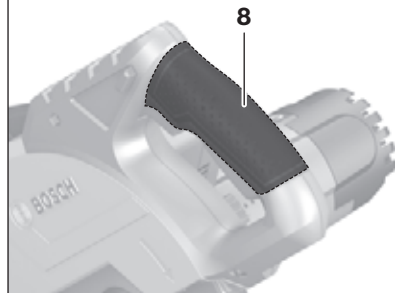

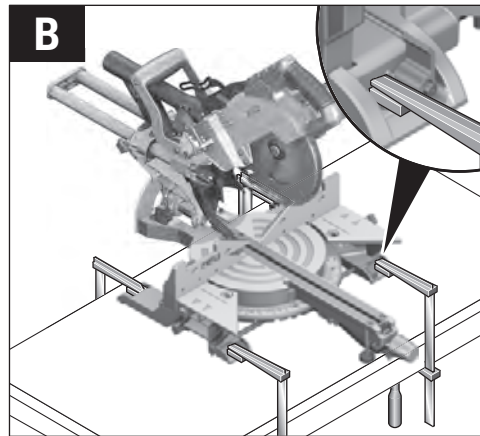
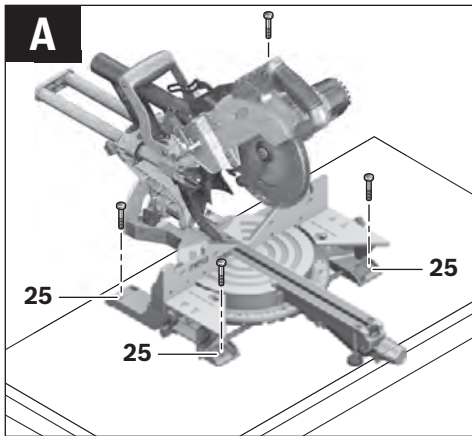
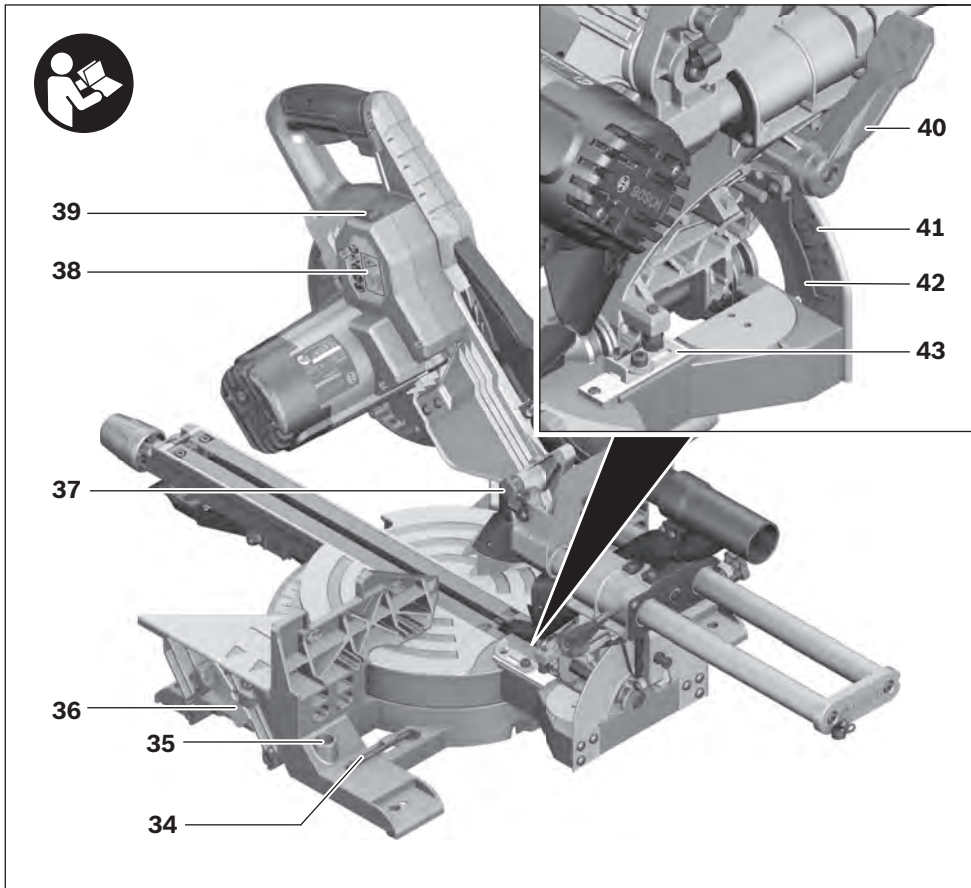

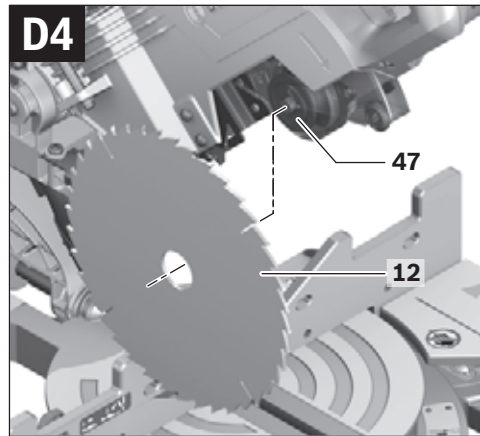
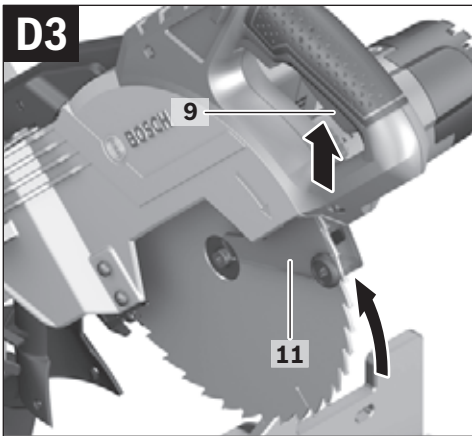
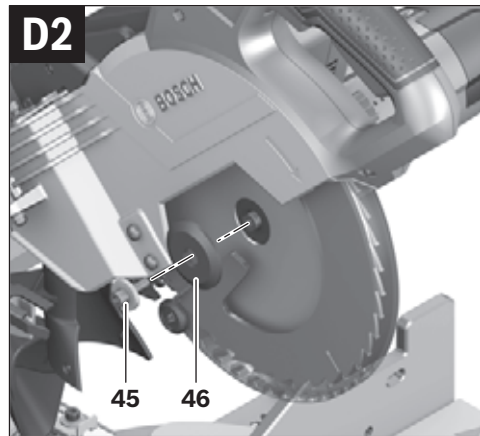
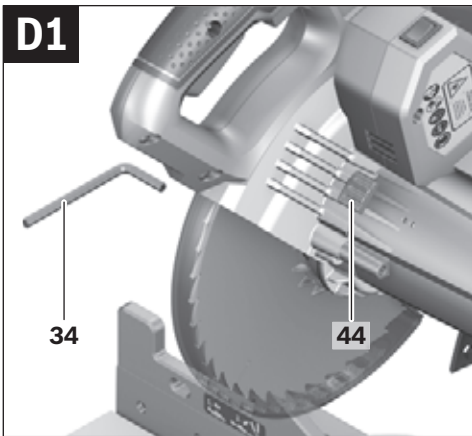
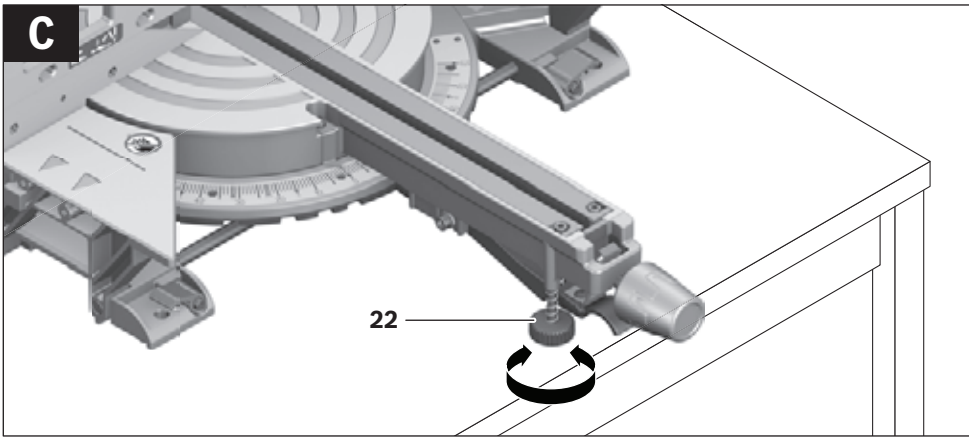

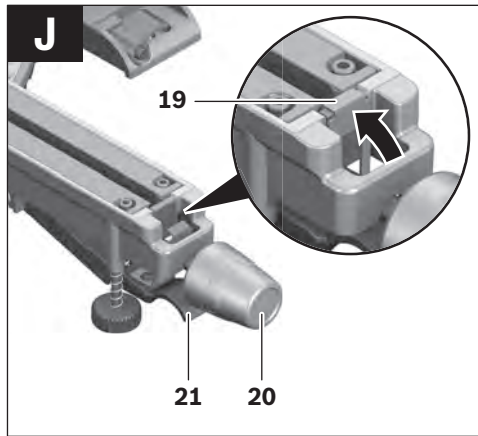
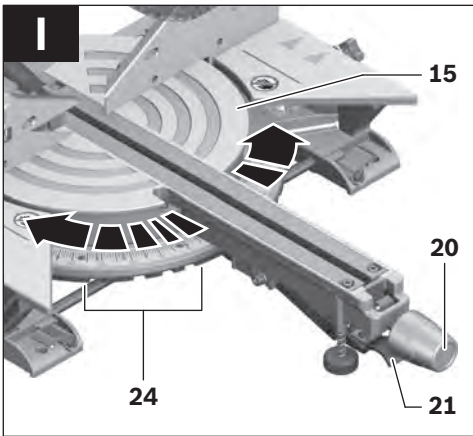
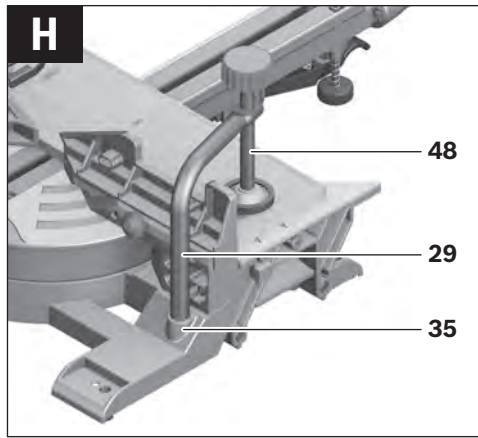
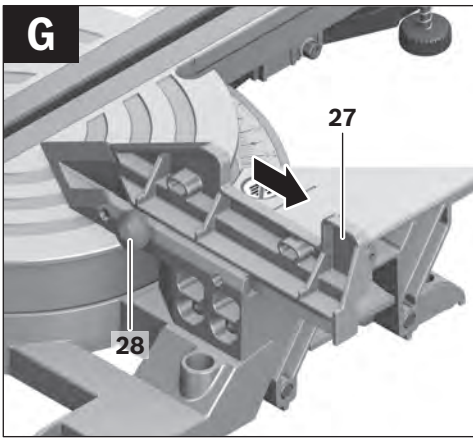
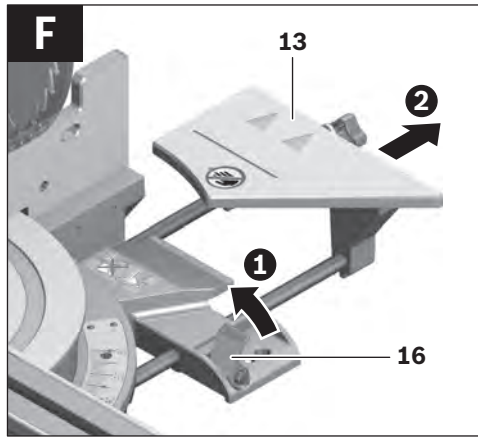
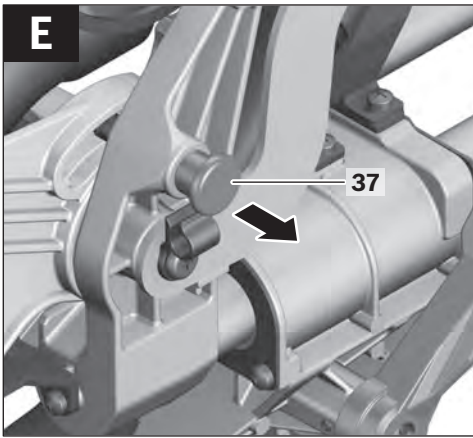

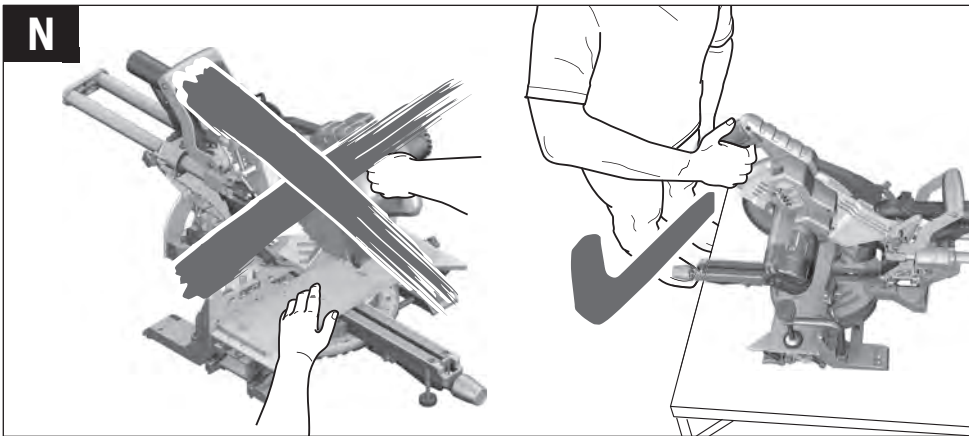
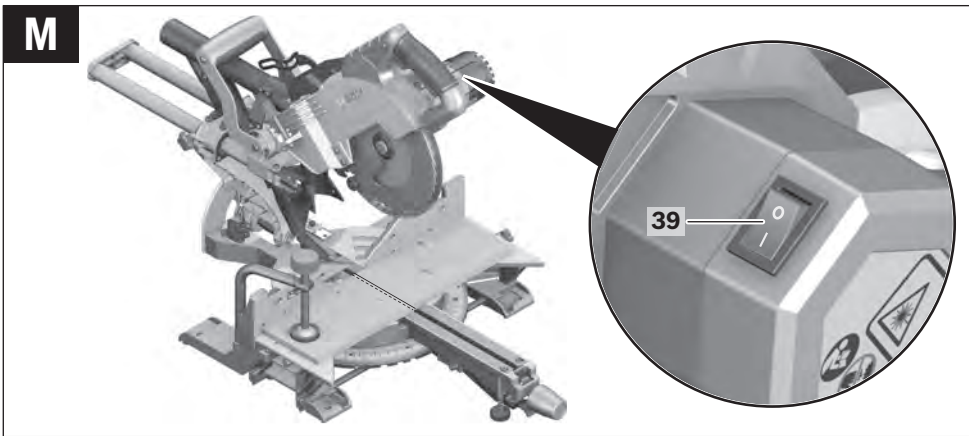
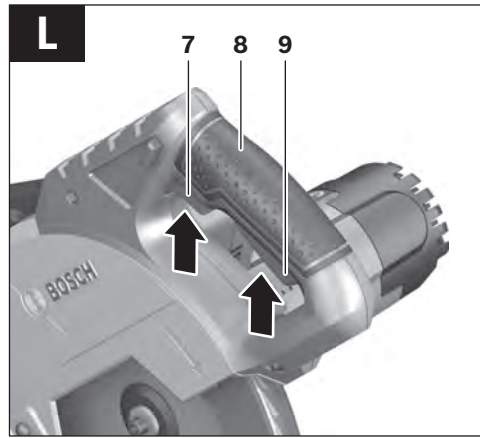
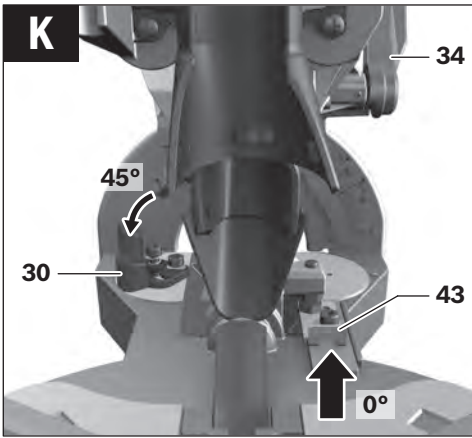

8 |

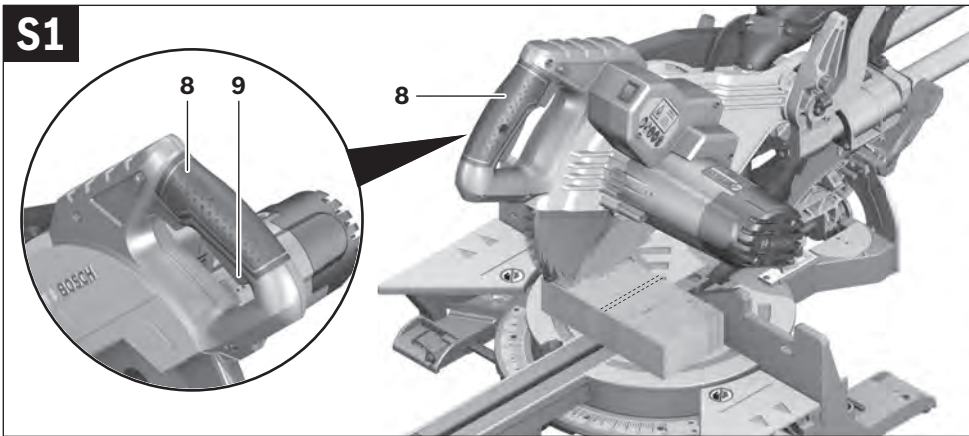
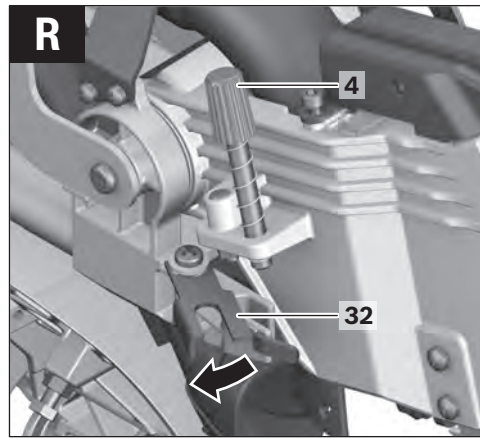
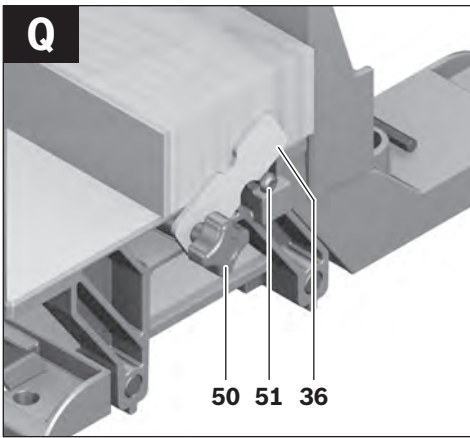
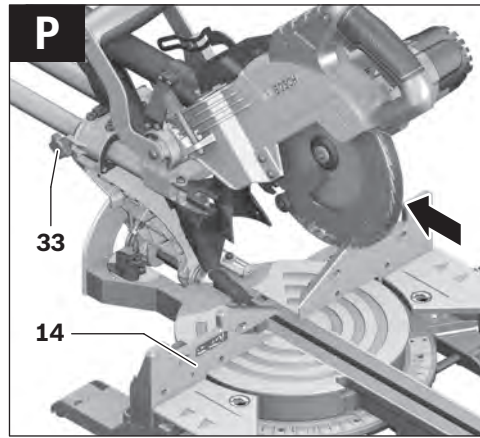
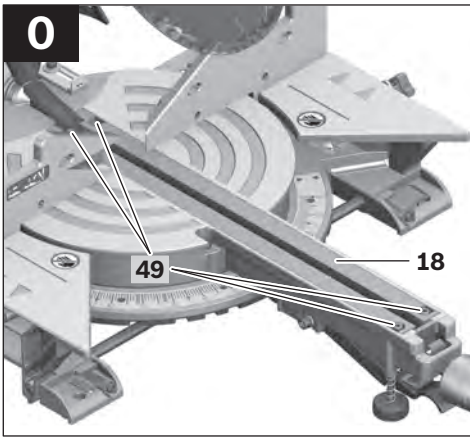

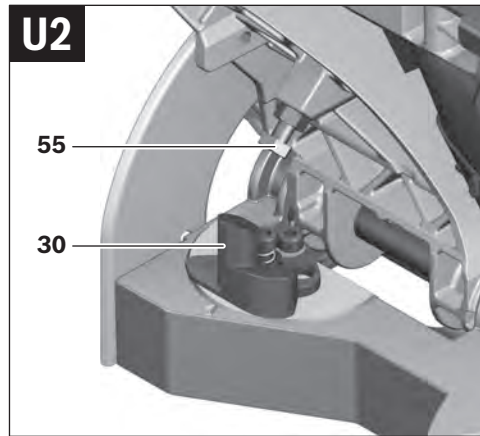
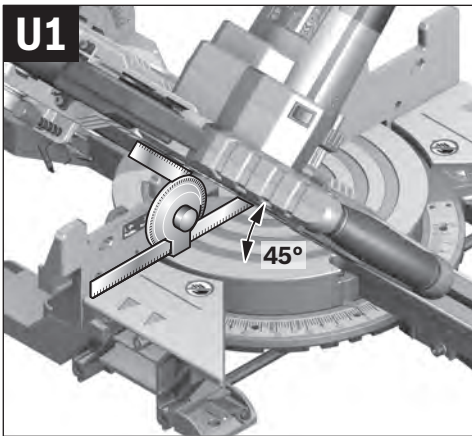
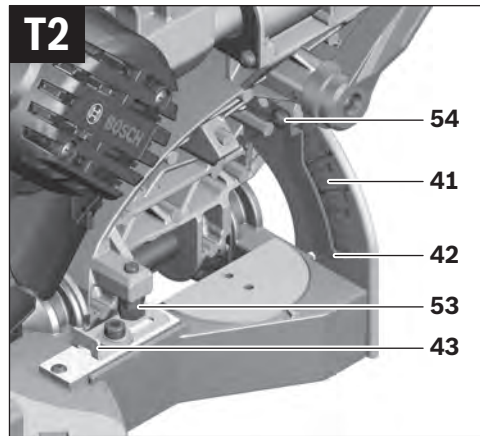
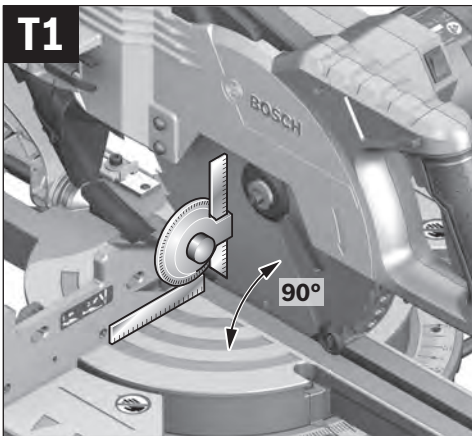
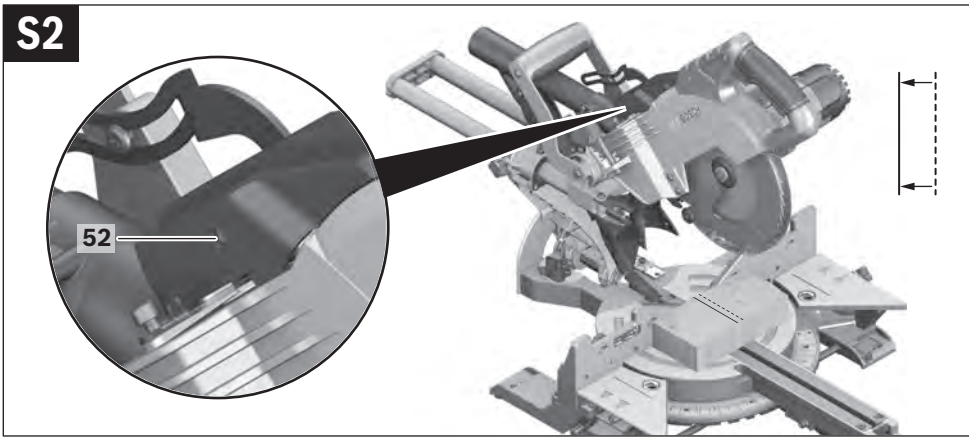

10 |

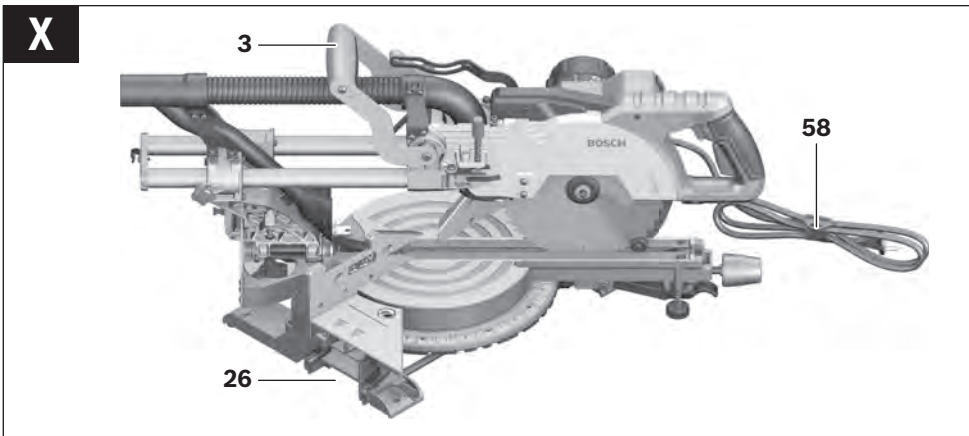
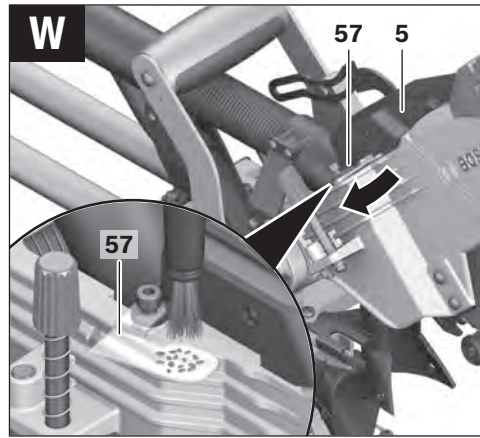
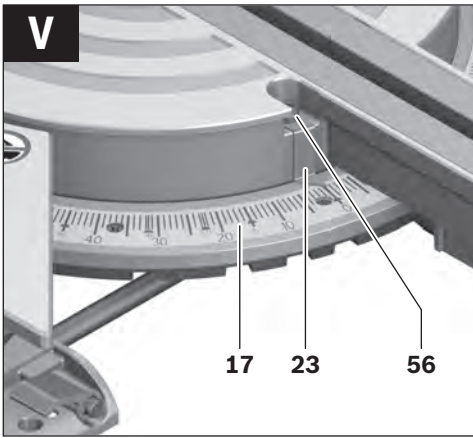

English

Safety Notes

General Power Tool Safety Warnings

⚠ WARNING When using electric tools basic safety precautions should always be followed to reduce the risk of fire, electric shock and personal injury including the following.

Read all these instructions before attempting to operate this product and save these instructions.

The term 'power tool' in the warnings refers to your mains-operated (corded) power tool or battery-operated (cordless) power tool.

Work area safety

- ▶ **Keep work area clean and well lit.** Cluttered or dark areas invite accidents.
- ▶ **Do not operate power tools in explosive atmospheres, such as in the presence of flammable liquids, gases or dust.** Power tools create sparks which may ignite the dust or fumes.
- ▶ **Keep children and bystanders away while operating a power tool.** Distractions can cause you to lose control.

Electrical safety

- ▶ **Power tool plugs must match the outlet. Never modify the plug in any way. Do not use any adapter plugs with earthed (grounded) power tools.** nmodified plugs and matching outlets will reduce risk of electric shock.
- ▶ **Avoid body contact with earthed or grounded surfaces, such as pipes, radiators, ranges and refrigerators.** There is an increased risk of electric shock if your body is earthed or grounded.
- ▶ **Do not expose power tools to rain or wet conditions.** Water entering a power tool will increase the risk of electric shock.
- ▶ **Do not abuse the cord. Never use the cord for carrying, pulling or unplugging the power tool. Keep cord away from heat, oil, sharp edges and moving parts.** Damaged or entangled cords increase the risk of electric shock.
- ▶ **When operating a power tool outdoors, use an extension cord suitable for outdoor use.** se of a cord suitable for outdoor use reduces the risk of electric shock.
- ▶ **If operating a power tool in a damp location is unavoidable, use a residual current device (RCD) protected supply.** se of an RCD reduces the risk of electric shock.

Personal safety

- ▶ **Stay alert, watch what you are doing and use common sense when operating a power tool. Do not use a power tool while you are tired or under the influence of drugs, alcohol or medication.** A moment of inattention while operating power tools may result in serious personal injury.
- ▶ **Use personal protective equipment. Always wear eye protection.** Protective equipment such as dust mask, non-skid safety shoes, hard hat, or hearing protection

used for appropriate conditions will reduce personal injuries.

- ▶ **Prevent unintentional starting. Ensure the switch is in the off-position before connecting to power source and/or battery pack, picking up or carrying the tool.** Carrying power tools with your finger on the switch or energising power tools that have the switch on invites accidents.
- ▶ **Remove any adjusting key or wrench before turning the power tool on.** A wrench or a key left attached to a rotating part of the power tool may result in personal injury.
- ▶ **Do not overreach. Keep proper footing and balance at all times.** This enables better control of the power tool in unexpected situations.
- ▶ **Dress properly. Do not wear loose clothing or jewellery. Keep your hair, clothing and gloves away from moving parts.** Loose clothes, jewellery or long hair can be caught in moving parts.
- ▶ **If devices are provided for the connection of dust extraction and collection facilities, ensure these are connected and properly used.** se of dust collection can reduce dust-related hazards.

Power tool use and care

- ▶ **Do not force the power tool. Use the correct power tool for your application.** The correct power tool will do the job better and safer at the rate for which it was designed.
- ▶ **Do not use the power tool if the switch does not turn it on and off.** Any power tool that cannot be controlled with the switch is dangerous and must be repaired.
- ▶ **Disconnect the plug from the power source and/or the battery pack from the power tool before making any adjustments, changing accessories, or storing power tools.** Such preventive safety measures reduce the risk of starting the power tool accidentally.
- ▶ **Store idle power tools out of the reach of children and do not allow persons unfamiliar with the power tool or these instructions to operate the power tool.** Power tools are dangerous in the hands of untrained users.
- ▶ **Maintain power tools. Check for misalignment or binding of moving parts, breakage of parts and any other condition that may affect the power tool s operation. If damaged, have the power tool repaired before use.** Many accidents are caused by poorly maintained power tools.
- ▶ **Keep cutting tools sharp and clean.** Properly maintained cutting tools with sharp cutting edges are less likely to bind and are easier to control.
- ▶ **Use the power tool, accessories and tool bits etc. in accordance with these instructions, taking into account the working conditions and the work to be performed.** se of the power tool for operations different from those intended could result in a hazardous situation.

Service

- ▶ **Have your power tool serviced by a qualified repair person using only identical replacement parts.** This will ensure that the safety of the power tool is maintained.

24 | English

Safety Warnings for Sliding Mitre Saws

- ▶ **The power tool is provided with a laser warning label (marked with number 38 in the representation of the power tool on the graphics page).**

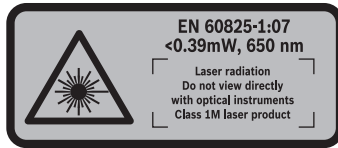

- ▶ **If the text of the warning label is not in your national language, stick the provided warning label in your national language over it before operating for the first time.**
- ▶ **Never make warning signs on the machine unrecognisable.**
- ▶ **Never stand on the power tool.** Serious injuries can occur when the power tool tips over or when inadvertently coming into contact with the saw blade.
- ▶ **Make sure that the guard operates properly and that it can move freely.** Never lock the guard in place when opened.
- ▶ **Never remove cutting remainders, wood chips, etc. from the sawing area while the machine is running.** Always guide the tool arm back to the neutral position first and then switch the machine off.
- ▶ **Guide the saw blade against the workpiece only when the machine is switched on.** Otherwise there is damage of kickback, when the saw blade becomes wedged in the workpiece.
- ▶ **Keep handles dry, clean, and free from oil and grease.** Greasy, oily handles are slippery causing loss of control.
- ▶ **Operate the power tool only when the work area to the workpiece is clear of any adjusting tools, wood chips, etc.** Small pieces of wood or other objects that come in contact with the rotating saw blade can strike the operator with high speed.
- ▶ **Keep the floor free of wood chips and material remainders.** You could slip or trip.
- ▶ **Always firmly clamp the piece to be worked. Do not saw workpieces that are too small to clamp.** Otherwise, the clearance of your hand to the rotating saw blade is too small.
- ▶ **Use the machine only for cutting the materials listed under Intended Use.** Otherwise, the machine can be subject to overload.
- ▶ **If the saw blade should become jammed, switch the machine off and hold the workpiece until the saw blade comes to a complete stop. To prevent kickback, the workpiece may not be moved until after the machine has come to a complete stop.** Correct the cause for the jamming of the saw blade before restarting the machine.
- ▶ **Do not use dull, cracked, bent or damaged saw blades.** Unsharpened or improperly set saw blades produce narrow kerf causing excessive friction, blade binding and kickback.

- ▶ **Always use saw blades with correct size and shape (diamond versus round) of arbor holes.** Saw blades that do not match the mounting hardware of the saw will run eccentrically, causing loss of control.
- ▶ **Do not use high speed steel (HSS) saw blades.** Such saw blades can easily break.
- ▶ **Do not touch the saw blade after working before it has cooled.** The saw blade becomes very hot while working.
- ▶ **Never operate the machine without the insert plate. Replace a defective insert plate.** Without flawless insert plates, injuries are possible from the saw blade.
- ▶ **Check the cable regularly and have a damaged cable repaired only through an authorised customer service agent for Bosch power tools. Replace damaged extension cables.** This will ensure that the safety of the power tool is maintained.
- ▶ **Store the machine in a safe manner when not being used. The storage location must be dry and lockable.** This prevents the machine from storage damage, and from being operated by untrained persons.
- ▶ **Do not direct the laser beam at persons or animals and do not stare into the laser beam yourself.** This power tool produces laser class 1M laser radiation according to EN 60825-1. Looking or viewing directly into the laser beam – especially with optical instruments such as binoculars etc. – can damage the eye.
- ▶ **Do not replace the installed laser with another laser type.** A laser that does not fit to this power tool could pose dangers for other persons.
- ▶ **Secure the workpiece.** A workpiece clamped with clamping devices or in a vice is held more secure than by hand.
- ▶ **Never leave the machine before it has come to a complete stop.** Cutting tools that are still running can cause injuries.
- ▶ **Never use the machine with a damaged cable. Do not touch the damaged cable and pull the mains plug when the cable is damaged while working.** Damaged cables increase the risk of an electric shock.

Products sold in GB only, our product is fitted with an BS 1363/A approved electric plug with internal fuse (ASTA approved to BS 1362).

If the plug is not suitable for your socket outlets, it should be cut off and an appropriate plug fitted in its place by an authorised customer service agent. The replacement plug should have the same fuse rating as the original plug.

The severed plug must be disposed of to avoid a possible shock hazard and should never be inserted into a mains socket elsewhere.

Products sold in AUS and NZ only, see a residual current device (RCD) with a rated residual current of 30 mA or less.

Symbols

The following symbols can be important for the operation of your power tool. Please memorise the symbols and their meanings. The correct interpretation of the symbols helps you operate the power tool better and more secure.

Symbols and their meaning



- ▶ **Laser radiation**
Do not view directly with optical instruments
Class 1M laser product



- ▶ **Keep hands away from the cutting area while the machine is running.** Danger of injury when coming in contact with the saw blade.



- ▶ **Wear a dust respirator.**



- ▶ **Wear safety goggles.**



- ▶ **Wear ear protectors.** Exposure to noise can cause hearing loss.



- ▶ **Danger area! Keep hands, fingers or arms away from this area.**



When sawing mitre/bevel angles, the adjustable fence must be pulled outward.



The free end of workpieces must be underlaid or supported by the saw-table extensions.

Symbols and their meaning

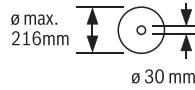

Observe the dimensions of the saw blade. The hole diameter must match the tool spindle without play. Do not use reducers or adapters.



Do not dispose of power tools into household waste!

Only for EC countries:

According to the European Guideline 2002/96/EC for Waste Electrical and Electronic Equipment and its implementation into national right, power tools that are no longer usable must be collected separately and disposed of in an environmentally correct manner.

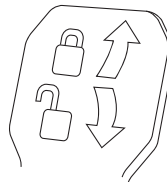

Clamping lever shut:

The set bevel angle of the tool arm is locked.

Clamping lever open:

Adjusting bevel angles is possible.

Product Description and Specifications



Read all safety warnings and all instructions. Failure to follow the warnings and instructions may result in electric shock, fire and/or serious injury.

Intended Use

The power tool is intended as a stationary machine for making straight lengthways and crossways cuts in hard and soft-wood, as well as in particle and fibre board. In this, mitre angles from -52° to $+60^\circ$ as well as bevel angles from -2° to $+47^\circ$ are possible.

When using appropriate saw blades, sawing aluminium profiles and plastic is also possible.

Product Features

The numbering of the components shown refers to the representation of the power tool on the graphic pages.

- 1 Slide device
- 2 Sawdust ejector
- 3 Transport handle
- 4 Adjusting screw of depth stop
- 5 Laser protection cap
- 6 Roller
- 7 On/Off switch
- 8 Handle
- 9 Locking switch for releasing the tool arm
- 10 Blade guard

26 | English

- 11 Retracting blade guard
- 12 Saw blade
- 13 Saw-Table extension
- 14 Fence
- 15 Saw table
- 16 Clamping lever of the saw-table extension
- 17 Scale for mitre angle
- 18 Insert plate
- 19 Locking bracket
- 20 Locking knob for various mitre angles
- 21 Mitre detent lever
- 22 Tilt protector
- 23 Mitre angle indicator
- 24 Detents for standard mitre angles
- 25 Mounting holes
- 26 Recessed handles
- 27 Adjustable fence
- 28 Locking screw of the adjustable fence
- 29 Material clamp
- 30 Stop for standard 45°, 22.5° and 33.9° bevel angles
- 31 Chip deflector
- 32 Depth stop
- 33 Locking screw for slide device
- 34 Allen key (5 mm)
- 35 Mounting holes for material clamp
- 36 Material stop
- 37 Transport safety-lock
- 38 Laser warning label
- 39 Laser on/off switch (for marking of cutting line)
- 40 Clamping lever for any bevel angle
- 41 Scale for bevel angle
- 42 Indicator for bevel angle
- 43 Stop for 0° standard bevel angle
- 44 Spindle lock
- 45 Allen screw (size 5 mm) for mounting of saw blade
- 46 Clamping flange
- 47 Interior clamping flange
- 48 Threaded rod
- 49 Screws for insert plate
- 50 Lock screw of the material stop
- 51 Clamping screw of the material stop
- 52 Adjustment screw for laser position (parallelism)
- 53 Stop screw for 0° bevel angle
- 54 Screw for bevel angle indicator
- 55 Stop screw for 45° bevel angle
- 56 Screw for mitre angle indicator
- 57 Laser lens cover
- 58 xelcro strap

*Accessories shown or described are not part of the standard delivery scope of the product. A complete overview of accessories can be found in our accessories program.

Noise/Vibration Information

Measured sound values determined according to EN 61029.

Typically the A-weighted noise levels of the product are,
Sound pressure level 99 dB(A) Sound power level
112 dB(A). uncertainty K 3 dB.

Wear hearing protection!

vibration total values a_{hv} (triax vector sum) and uncertainty K determined according to EN 61029,
 a_{hv} 2.5 m/s², K 1.5 m/s².

The vibration emission level given in this information sheet has been measured in accordance with a standardised test given in EN 61029 and may be used to compare one tool with another. It may be used for a preliminary assessment of exposure.

The declared vibration emission level represents the main applications of the tool. However if the tool is used for different applications, with different accessories or poorly maintained, the vibration emission may differ. This may significantly increase the exposure level over the total working period.

An estimation of the level of exposure to vibration should also take into account the times when the tool is switched off or when it is running but not actually doing the job. This may significantly reduce the exposure level over the total working period.

Identify additional safety measures to protect the operator from the effects of vibration such as, maintain the tool and the accessories, keep the hands warm, organisation of work patterns.

Declaration of Conformity 

We declare under our sole responsibility that the product described under 'Technical Data' is in conformity with the following standards or standardization documents, EN 61029, EN 60725-1 according to the provisions of the directives 2011/65/EU, 2004/107/EC, 2006/42/EC.

Technical file (2006/42/EC) at,
Robert Bosch GmbH, PT/ETM9,
D-70745 Leinfelden-Echterdingen

Dr. Egbert Schneider	Helmut Heinzelmann
Senior vice President	Head of Product Certification
Engineering	PT/ETM9



Robert Bosch GmbH, Power Tools Division
D-70745 Leinfelden-Echterdingen
Leinfelden, 05.11.2012

Technical Data

Sliding Mitre Saw		GCM 8 SJL		
Article number		3 601 M19 160	3 601 M19 190	3 601 M19 1..
Rated power input	W	1250	1400	1600
No-load speed	min ⁻¹	5500	5500	5500
Reduced starting current		●	●	●
Laser type	nm	650	650	650
	mW	0.39	0.39	0.39
Laser class		1M	1M	1M
Weight according to EPTA-Procedure 01/2003	kg	17.3	17.3	17.3
Protection class		□/II	□/II	□/II
Permissible workpiece dimensions (maximal/minimal) see page 30.				
The values given are valid for a nominal voltage \bar{U} of 230 V. For different voltages and models for specific countries, these values can vary.				

Dimension of suitable saw blades

Saw blade diameter	mm	210 – 216
Blade body thickness	mm	1.3 – 1.7
Mounting hole diameter	mm	30

Assembly

- ▶ **Avoid unintentional starting of the machine. During assembly and for all work on the machine, the power plug must not be connected to the mains supply.**

Delivery Scope

Before starting the operation of the machine for the first time, check if all parts listed below have been supplied,.

- Sliding mitre saw with premounted saw blade
- Material clamp **29**
- Allen key **34**

Note: Check the power tool for possible damage. Before further use of the machine, check that all protective devices are fully functional. Any lightly damaged parts must be carefully checked to ensure flawless operation of the tool. All parts must be properly mounted and all conditions fulfilled that ensure faultless operation. Damaged protective devices and parts must be immediately replaced by an authorised service centre.

Stationary or Flexible Mounting

- ▶ **To ensure safe handling, the machine must be mounted on a level and stable surface (e. g., workbench) prior to using.**

Mounting to a Working Surface (see figures A B)

- Fasten the power tool with suitable screw fasteners to the working surface. The mounting holes **25** serve for this purpose.

or

- Clamp the power tool with commercially available screw clamps by the feet to the working surface.

Mounting to a Bosch Saw Stand

With the height-adjustable legs, Bosch GTA saw stands provide firm support for the power tool on any surface. The workpiece supports of the saw stand are used for underlaying long workpieces.

- ▶ **Read all safety warnings and instructions included with the worktable.** Failure of observing safety warnings and instructions can lead to electrical shock, fire and/or cause serious injuries.
- ▶ **Assemble the worktable properly before mounting the power tool.** Perfect assembly is important in order to prevent the risk of collapsing.
 - Mount the power tool in transport position on the saw stand.

Flexible Mounting (not recommended!) (see figure C)

In exceptional cases, when it is not possible to mount the machine onto a level and stable work surface, it can be set up using the tilt protector.

- ▶ **Without the use of the tilt protector, the machine does not stand safely and can tip over, especially when sawing at maximum mitre/bevel angles.**
 - Screw the tilt protector **22** in or out until the machine is positioned level on the working surface.

Dust/Chip Extraction

Dusts from materials such as lead-containing coatings, some wood types, minerals and metal can be harmful to one's health. Touching or breathing-in the dusts can cause allergic reactions and/or lead to respiratory infections of the user or bystanders.

Certain dusts, such as oak or beech dust, are considered as carcinogenic, especially in connection with wood-treatment additives (chromate, wood preservative). Materials containing asbestos may only be worked by specialists.

- Always use dust extraction.
- Provide for good ventilation of the working place.
- It is recommended to wear a P2 filter-class respirator.

Observe the relevant regulations in your country for the materials to be worked.

28 | English

- ▶ **Prevent dust accumulation at the workplace.** Dusts can easily ignite.

The dust/chip extraction can be blocked by dust, chips or workpiece fragments.

- Switch the machine off and pull the mains plug from the socket outlet.
- Wait until the saw blade has come to a complete stop.
- Determine the cause of the blockage and correct it.

External Dust Extraction

For dust extraction, a vacuum hose (size Ø 35 mm) can also be connected to the dust ejector **2**.

- Connect the vacuum hose with the sawdust ejector **2**.

The vacuum cleaner must be suitable for the material being worked.

When vacuuming dry dust that is especially detrimental to health or carcinogenic, use a special vacuum cleaner.

Changing the Saw Blade (see figures D1 – D4)

- ▶ **When mounting the saw blade, wear protective gloves.**

Danger of injury when touching the saw blade.

se only saw blades whose maximum permitted speed is higher than the no-load speed of the power tool.

se only saw blades that correspond with the characteristic data given in these operation instructions and that are tested and marked in accordance with EN ? 47-1.

se only saw blades recommended by the tool manufacturer, and suitable for sawing the materials to be cut.

Removing the Saw Blade

- Bring the power tool into the working position.
- Turn Allen screw **45** with the Allen key (5 mm) **34** and at the same time press the spindle lock **44** until it engages.
- Hold the spindle lock **44** pressed and unscrew the Allen screw **45** in clockwise direction (left-hand thread!).
- Remove the clamping flange **46**.
- Press locking switch **9** and swing back the retracting blade guard **11** to the stop.
- Hold the retracting blade guard in this position and remove the saw blade **12**.
- Slowly guide the retracting blade guard downward again.

Mounting the Saw Blade

If required, clean all parts to be mounted prior to assembly.

- Press locking switch **9**, swing back the retracting blade guard **11** to the stop and hold it in this position.
- Place the new saw blade onto the interior clamping flange **47**.
- ▶ **When mounting the saw blade, pay attention that the cutting direction of the teeth (arrow direction on the saw blade) corresponds with the direction of the arrow on the blade guard!**
- Slowly guide the retracting blade guard downward again.
- Place on the clamping flange **46** and the screw **45**. Press the spindle lock **44** until it engages and tighten the screw turning in anticlockwise direction.

Operation

- ▶ **Before any work on the machine itself, pull the mains plug.**

Transport Safety (see figure E)

The transport safety-lock **37** enables easier handling of the machine when transporting to various working locations.

Releasing the Machine (Working Position)

- Push the tool arm by the handle **8** down a little in order to relieve the transport safety-lock **37**.
- Pull the transport safety-lock **37** completely outward.
- Guide the tool arm slowly upward.

Securing the Machine (Transport Position)

- Loosen the locking screw **33** if tightened. Pull the tool arm completely to the front and tighten the locking screw again.
- Screw adjusting screw **4** completely upward.
- To lock the saw table **15**, tighten the locking knob **20**.
- Press locking switch **9** and slowly guide the tool arm downward by the handle **8**.
- Guide the tool arm downward until the transport safety-lock **37** can be pushed completely inward.

Preparing for Operation

Extending the Saw Table (see figure F)

Long workpieces must be underlaid or supported at their free end.

The saw table can be extended left and right with the saw-table extensions **13**.

- Push clamping lever **16** upward.
- Pull out the saw-table extension **13** to the desired length.
- To lock the saw-table extension, push clamping lever **16** down again.

Moving the Fence (see figure G)

When sawing bevel angles, the adjustable fence **27** must be pulled outward or removed completely.

Mitre/Bevel Angle		
Vertical	Horizontal	
–2° – 47°	44°	– Loosen locking screw 28 .
	(rightward)	– Pull the adjustable fence 27 completely outward.
0° – 47°	45°	– Remove locking screw 28 .
	(rightward)	– Pull the adjustable fence 27 completely outward.
		– Remove the adjustable fence upward.

Clamping the Workpiece (see figure H)

To ensure optimum working safety, the workpiece must always be firmly clamped.

Do not saw workpieces that are too small to clamp.

- Press the workpiece firmly against the fence **14**.
- Insert the material clamp **29** provided into one of the holes **35** intended for it.
- Adapt the threaded rod **48** of the screw clamp to the workpiece height.

- Firmly tighten the threaded rod **48**, thus fastening the workpiece.

Adjusting Mitre Angles

To ensure precise cuts, the basic adjustment of the machine must be checked and adjusted as necessary after intensive use (see 'Checking and Adjusting the Basic Adjustment', page 30).

Adjusting Standard Mitre Angles (see figure I)

For quick and precise adjustment of commonly used mitre angles, detents **24** have been provided for on the saw table.

Left	Right
0°	
45°	31.6°
22.5°	15°
15°	22.5°
31.6°	45°
60°	

- Loosen the locking knob **20** in case it is tightened.
- Pull lever **21** and rotate the saw table **15** left or right to the requested detent.
- Release the lever again. The lever must be felt to engage in the detent.

Adjusting Any Mitre Angle (see figure J)

The mitre angle can be set in the range from 52° (left side) to 60° (right side).

- Loosen the locking knob **20** in case it is tightened.
- Pull lever **21** and at the same time push the locking bracket **19** until it engages in the groove intended for this. The saw table can be moved freely now.
- Turn the saw table **15** left or right by the locking knob until the angle indicator **23** indicates the requested mitre angle.

For mitre angles greater than 45°:

- Pull the saw-table extension **13** completely outward (see 'Extending the Saw Table', page 27).
- Tighten the locking knob **20** again.
- To loosen the lever **21** again (for adjusting standard mitre angles), pull the lever upward.
The locking bracket **19** snaps back to its original position and lever **21** can re-engage into the detents **24**.

Adjusting Bevel Angles

Adjusting Standard Bevel Angles (see figure K)

For quick and precise setting of frequently used bevel angles, stops have been provided for the 0°, 45°, 22.5° and 33.9° angles.

- Loosen clamping lever **40**.
- Adjust stops **30** or **43** as follows.

Mitre/Bevel Angle	Stop	Adjustment
0°	43	Push the stop completely to the rear
45°	30	Turn the stop completely to the front
22.5°	30	Turn the stop to the centre
33.9°	30	Turn the stop completely to the rear

- Swing the tool arm with the handle **8** to the requested position.
- Tighten clamping lever **40** again.

Adjusting Any Bevel Angle

The bevel angle can be set in a range from -2° to +47°.

- Loosen clamping lever **40**.
- Turn stop **30** completely to the rear and pull stop **43** completely to the front.
The complete tilting range is now available.
- Tilt the tool arm by the handle **8** until the angle indicator **42** indicates the desired bevel angle.
- Hold the tool arm in this position and tighten clamping lever **40** again.

Starting Operation

- ▶ **Observe correct mains voltage! The voltage of the power source must agree with the voltage specified on the nameplate of the machine. Power tools marked with 230 V can also be operated with 220 V.**

Switching On (see figure L)

- For **starting operation**, pull the On/Off switch **7** in the direction of the handle **8**.

Note: For safety reasons, the On/Off switch **7** cannot be locked. It must remain pressed during the entire operation.

The tool arm can only be guided downward by pressing locking switch **9**.

- For **sawing**, you must therefore press locking switch **9** in addition to pressing the On/Off switch.

Switching Off

- To **switch off** the machine, release the On/Off switch **7**.

When not using the power tool, switch it off in order to save energy.

Working Advice

General Sawing Instructions

- ▶ **For all cuts, it must first be ensured that the saw blade at no time can come in contact with the fence, screw clamps or other machine parts. Remove possibly mounted auxiliary stops or adjust them accordingly.**

Protect the saw blade against impact and shock. Do not subject the saw blade to lateral pressure.

Do not saw warped/bent workpieces. The workpiece must always have a straight edge to face against the fence.

Long workpieces must be underlaid or supported at their free end.

Marking the Cutting Line (see figure M)

A laser beam indicates the cutting line of the saw blade. This allows for exact positioning of the workpiece for sawing, without having to open the retracting blade guard.

- For this, switch the laser beam on with the switch **39**.
- Align the cutting mark on your workpiece with reference to the right-hand edge of the laser line.

Note: Before sawing, check if the cutting line is still indicated correctly (see 'Adjusting the Laser', page 31). The laser beam, as an example, can misadjust due to vibrations after intensive use.

30 | English

Position of the Operator (see figure N)

- ▶ **Do not stand in a line with the saw blade in front of the machine. Always stand aside of the saw blade.** This protects your body against possible kickback.
- Keep hands, fingers and arms away from the rotating saw blade.
- Do not cross your arms when operating the tool arm.

Permissible Workpiece Dimensions

Maximal workpiece sizes,

Mitre/Bevel Angle		Height x Width [mm]
Horizontal	Vertical	
0°	0°	70 x 312
45° (leftward/rightward)	0°	70 x 225
0°	45°	45 x 312
45° (leftward)	45°	45 x 225
45° (rightward)	45°	45 x 225

Minimal workpiece sizes (all workpieces that can be clamped left or right from the saw blade with the supplied material clamp **29**), 100 x 40 mm (length x width)

Cutting depth, max. (0°/0°), 70 mm

Replacing Insert Plates (see figure O)

The red insert plates **18** can become worn after prolonged use of the machine.

Replace defective insert plates.

- Bring the power tool into the working position.
- Loosen the screws **49** with an Allen key (size 4 mm) and remove the old insert plates.
- Insert the new right-hand insert plate.
- Screw the insert plate as far as possible to the right with the screws **49** so that the saw blade does not come into contact with the insert plate over the complete length of the possible slide motion.
- Repeat the work steps in the same manner for the left-hand insert plate.

Sawing

- ▶ **Always tighten the locking knob 20 firmly before sawing.** Otherwise the saw blade can become wedged in the workpiece.

Sawing without Slide Movement (Cutting Off) (see figure P)

- For cuts without slide movement (small workpieces), loosen the locking screw **33** in case it is tightened. Slide the tool arm to the stop in the direction of the fence **14** and retighten the locking screw **33**.
- Set the desired mitre angle.
- Firmly clamp the workpiece as appropriate for its dimensions.
- Switch on the machine.
- Press locking switch **9** and slowly guide the tool arm downward by the handle **8**.
- Saw through the workpiece applying uniform feed.

- Switch off the machine and wait until the saw blade has come to a complete stop.
- Guide the tool arm slowly upward.

Sawing with Slide Movement

- For cuts using the slide device **1** (wide workpieces), loosen the locking screw **33** in case it is tightened.
- Set the desired mitre angle.
- Firmly clamp the workpiece as appropriate for its dimensions.
- Pull the tool arm away from the fence **14** far enough so that the saw blade is in front of the workpiece.
- Switch on the machine.
- Press locking switch **9** and slowly guide the tool arm downward by the handle **8**.
- Press the tool arm in the direction of the fence **14** and saw through the workpiece applying uniform feed.
- Switch off the machine and wait until the saw blade has come to a complete stop.
- Guide the tool arm slowly upward.

Sawing Workpieces of the Same Length (see figure Q)

The material stop **36** (accessory) can be used for easily sawing workpieces to the same length.

The material stop can be mounted on either side of the saw table extension **13**.

- Loosen lock screw **50** and swing the material stop **36** over clamping screw **51**.
- Retighten lock screw **50**.
- Adjust the saw table extension **13** to the desired length (see 'Extending the Saw Table', page 22).

Adjusting the Depth Stop (Sawing Grooves) (see figure R)

The depth stop must be adjusted when a trench gap is to be sawed.

- Swivel the depth stop **32** outward.
- Press locking lever **9** and tilt the tool arm to the desired position.
- Turn adjusting screw **4**, until the screw end touches depth stop **32**.
- Guide the tool arm slowly upward.

Special Workpieces

When sawing curved or round workpieces, these must be especially secured against slipping. At the cutting line, no gap may exist between workpiece, fence and saw table.

Provide for special fixtures, if required.

Checking and Adjusting the Basic Adjustment

- ▶ **Before any work on the machine itself, pull the mains plug.**

To ensure precise cuts, the basic adjustment of the machine must be checked and adjusted as necessary after intensive use.

A certain level of experience and appropriate specialty tools are required for this.

A Bosch after-sales service station will handle this maintenance task quickly and reliably.

Adjusting the Laser

Note: To test the laser function, the machine must be connected to power.

- ▶ **While adjusting the laser (e. g. when moving the tool arm), never actuate the On/Off switch.** Accidental starting of the power tool can lead to injuries.
- Bring the power tool into the working position.
- Turn the saw table **15** to the 0° detent **24**. The lever **21** must be felt to engage in the detent.
- Switch the laser beam on with switch **39**.

Checking: (see figure S1)

- Draw a straight cutting line on the workpiece.
- Press locking switch **9** and slowly guide the tool arm downward by the handle **8**.
- Align the workpiece in such a manner that the teeth of the saw blade are in alignment with the cutting line.
- Hold the workpiece in this position and slowly guide the tool arm upward again.
- Clamp the workpiece.

The laser beam must be in alignment with the cutting line on the workpiece over the complete length, also when the tool arm is lowered.

Adjusting: (see figure S2)

- Screw the adjustment screw **52** in or out using a suitable screwdriver until the laser beam is parallel with the cutting line on the workpiece over the complete length.

One rotation in anticlockwise direction moves the laser beam from left to right one rotation in clockwise direction moves the laser beam from right to left.

Setting the Standard Bevel Angle 0° (Vertical)

- Bring the power tool into the working position.
- Turn the saw table **15** to the 0° detent **24**. The lever **21** must be felt to engage in the detent.

Checking: (see figure T1)

- Adjust an angle gauge to 90° and position it on the saw table **15**.

The leg of the angle gauge must be flush with the saw blade **12** over the complete length.

Adjusting: (see figure T2)

- Loosen clamping lever **40**.
- Push the stop **43** completely to the rear.
- Loosen the lock nut of the stop screw **53** using a commercial box-end or open-end spanner (size 10 mm).
- Screw the stop screw in or out until the leg of the angle gauge is flush with the saw blade over the complete length.
- Tighten clamping lever **40** again.
- Afterwards, retighten the lock nut of the stop screw **53** again.

In case the angle indicator **42** is not in a line with the 0° mark of the scale **41** after the adjustment, loosen the screw **54** using a commercial Phillips screwdriver and align the angle indicator along the 0° mark.

Setting the Standard Bevel Angle 45° (Vertical)

- Bring the power tool into the working position.
- Turn the saw table **15** to the 0° detent **24**. The lever **21** must be felt to engage in the detent.
- Turn the stop **30** completely to the front.
- Loosen clamping lever **40** and tilt the tool arm by handle **8** leftward to the stop (45°).

Checking: (see figure 1)

- Adjust an angle gauge to 45° and position it on the saw table **15**.

The leg of the angle gauge must be flush with the saw blade **12** over the complete length.

Adjusting: (see figure 2)

- Loosen the lock nut of the stop screw **55** using a commercial box-end or open-end spanner (size 10 mm).
- Screw the stop screw in or out until the leg of the angle gauge is flush with the saw blade over the complete length.
- Tighten clamping lever **40** again.
- Afterwards, retighten the lock nut of the stop screw **55** again.

In case the angle indicator **42** is not in a line with the 45° mark of the scale **41**, firstly check the 0° setting for the bevel angle and the angle indicator again. Then repeat the adjustment of the 45° bevel angle.

Aligning the Angle Indicator (Horizontally) (see figure V)

- Bring the power tool into the working position.
- Turn the saw table **15** to the 0° detent **24**. The lever **21** must be felt to engage in the detent.

Checking:

The angle indicator **23** must be in alignment with the 0° mark of the scale **17**.

Adjusting:

- Loosen screw **56** using a Phillips screwdriver and align the angle indicator alongside the 0° mark.
- Retighten the screw again.

Transport (see figure X)

Before transporting the power tool, the following steps must be carried out,

- Loosen the locking screw **33** if tightened. Pull the tool arm completely to the front and tighten the locking screw again.
- Make sure that the depth stop **32** is pushed completely inward and that adjusting screw **4** fits through the recess without touching the depth stop when moving the tool arm.
- Bring the machine into the transport position.
- Remove all accessories that cannot be mounted firmly to the power tool.
If possible, place unused saw blades in an enclosed container for transport.
- Wind up the mains cable and tie it together with xelcro strap **58**.
- Carry the machine by the transport handle **3** or hold it by the recessed handles **26** on the sides of the saw table.

32 | English

- ▶ **The power tool should always be carried by two persons in order to avoid back injuries.**
- ▶ **When transporting the power tool, use only the transport devices and never use the protective devices.**

Maintenance and Service

Maintenance and Cleaning

- ▶ **Before any work on the machine itself, pull the mains plug.**

If the machine should fail despite the care taken in manufacturing and testing procedures, repair should be carried out by an after-sales service centre for Bosch power tools.

In all correspondence and spare parts order, please always include the 10-digit article number given on the type plate of the machine.

If the replacement of the supply cord is necessary, this has to be done by Bosch or an authorized Bosch service agent in order to avoid a safety hazard.

Cleaning

For safe and proper working, always keep the power tool and its ventilation slots clean.

The retracting blade guard must always be able to move freely and retract automatically. Therefore, always keep the area around the retracting blade guard clean.

Remove dust and chips after each working procedure by blowing out with compressed air or with a brush.

Clean the roller **6** regularly.

To clean the laser unit, turn the laser lens cover **57** outward and remove any dust using a brush. (see figure W)

Accessories

	Article number
Material clamp	1 609 B04 224
Insert plates	1 609 B03 717
Dust bag	1 609 B00 ? 40
Length stop	1 609 B02 365
Lock screw of the material stop	1 609 B00 263

Saw blades for wood and plate materials, panels and strips/mouldings

Saw blade 216 x 30 mm, 4? teeth	2 60? 640 641
---------------------------------	---------------

Saw blades for plastic and non-ferrous metals

Saw blade 216 x 30 mm, ?0 teeth	2 60? 640 447
---------------------------------	---------------

Saw blades for all types of laminate flooring

Saw blade 216 x 30 mm, 60 teeth	2 60? 642 133
---------------------------------	---------------

After-sales Service and Application Service

Our after-sales service responds to your questions concerning maintenance and repair of your product as well as spare parts. Exploded views and information on spare parts can also be found under,

www.bosch-pt.com

Bosch's application service team will gladly answer questions concerning our products and their accessories.

Great Britain

Robert Bosch Ltd. (B.S.C.)

P.O. Box 9?

Broadwater Park

North Orbital Road

Denham

xbridge

B 9 5H

Tel. Service., (0? 44) 7360109

Fax., (0? 44) 7360146

E-Mail., boschservicecentre@bosch.com

Ireland

Origo Ltd.

Unit 23 Magna Drive

Magna Business Park

City West

Dublin 24

Tel. Service., (01) 4666700

Fax., (01) 4666???

Australia, New Zealand and Pacific Islands

Robert Bosch Australia Pty. Ltd.

Power Tools

Locked Bag 66

Clayton South VIC 3169

Customer Contact Center

Inside Australia.,

Phone., (01300) 307044

Fax., (01300) 307045

Inside New Zealand.,

Phone., (0? 00) 543353

Fax., (0? 00) 42? 570

Outside Australia and New Zealand.,

Phone., +61 3 95415555

www.bosch.com.au

Republic of South Africa

Customer service

Hotline., (011) 6519600

Gauteng BSC Service Centre

35 Roper Street, New Centre

Johannesburg

Tel., (011) 4939375

Fax., (011) 4930126

E-Mail., bsctools@icon.co.za

KZN BSC Service Centre

Unit E, Almar Centre
143 Crompton Street
Pinetown
Tel., (031) 7012120
Fax., (031) 7012446
E-Mail., bsc.dur@za.bosch.com

Western Cape BSC Service Centre

Democracy Way, Prosperity Park
Milnerton
Tel., (021) 5512577
Fax., (021) 5513223
E-Mail., bsc@zsd.co.za

Bosch Headquarters

Midrand, Gauteng
Tel., (011) 6519600
Fax., (011) 6519??0
E-Mail., rbsa-hq.pts@za.bosch.com

Disposal

The machine, accessories and packaging should be sorted for environmental-friendly recycling.

Do not dispose of power tools into household waste!

Only for EC countries:

According to the European Guideline 2002/96/EC for Waste Electrical and Electronic Equipment and its implementation into national law, power tools that are no longer usable must be collected separately and disposed of in an environmentally correct manner.

Subject to change without notice.