

**Robert Bosch GmbH**  
Power Tools Division  
70745 Leinfelden-Echterdingen  
Germany

[www.bosch-pt.com](http://www.bosch-pt.com)

1 609 929 W38 (2010.07) T / 396 UNI



1 609 929 W38

## GML 50 Professional



<b>de</b> Originalbetriebsanleitung	<b>el</b> Πρωτότυπο οδηγιών χρήσης	<b>sr</b> Originalno uputstvo za rad
<b>en</b> Original instructions	<b>tr</b> Orijinal işletme talimatı	<b>sl</b> Izvirna navodila
<b>fr</b> Notice originale	<b>pl</b> Instrukcja oryginalna	<b>hr</b> Originalne upute za rad
<b>es</b> Manual original	<b>cs</b> Původní návod k používání	<b>et</b> Algupärane kasutusjuhend
<b>pt</b> Manual original	<b>sk</b> Pôvodný návod na použitie	<b>lv</b> Instrukcijas oriģinālvalodā
<b>it</b> Istruzioni originali	<b>hu</b> Eredeti használati utasítás	<b>lt</b> Originali instrukcija
<b>nl</b> Oorspronkelijke gebruiksaanwijzing	<b>ru</b> Оригинальное руководст- во по эксплуатации	<b>ar</b> تعليمات التشغيل الأصلية
<b>da</b> Original brugsanvisning	<b>uk</b> Оригінальна інструкція з експлуатації	<b>fa</b> راهنمای طرز کار اصلی
<b>sv</b> Bruksanvisning i original	<b>ro</b> Instrucțiuni originale	
<b>no</b> Original driftsinstruks	<b>bg</b> Оригинална инструкция	
<b>fi</b> Alkuperäiset ohjeet		



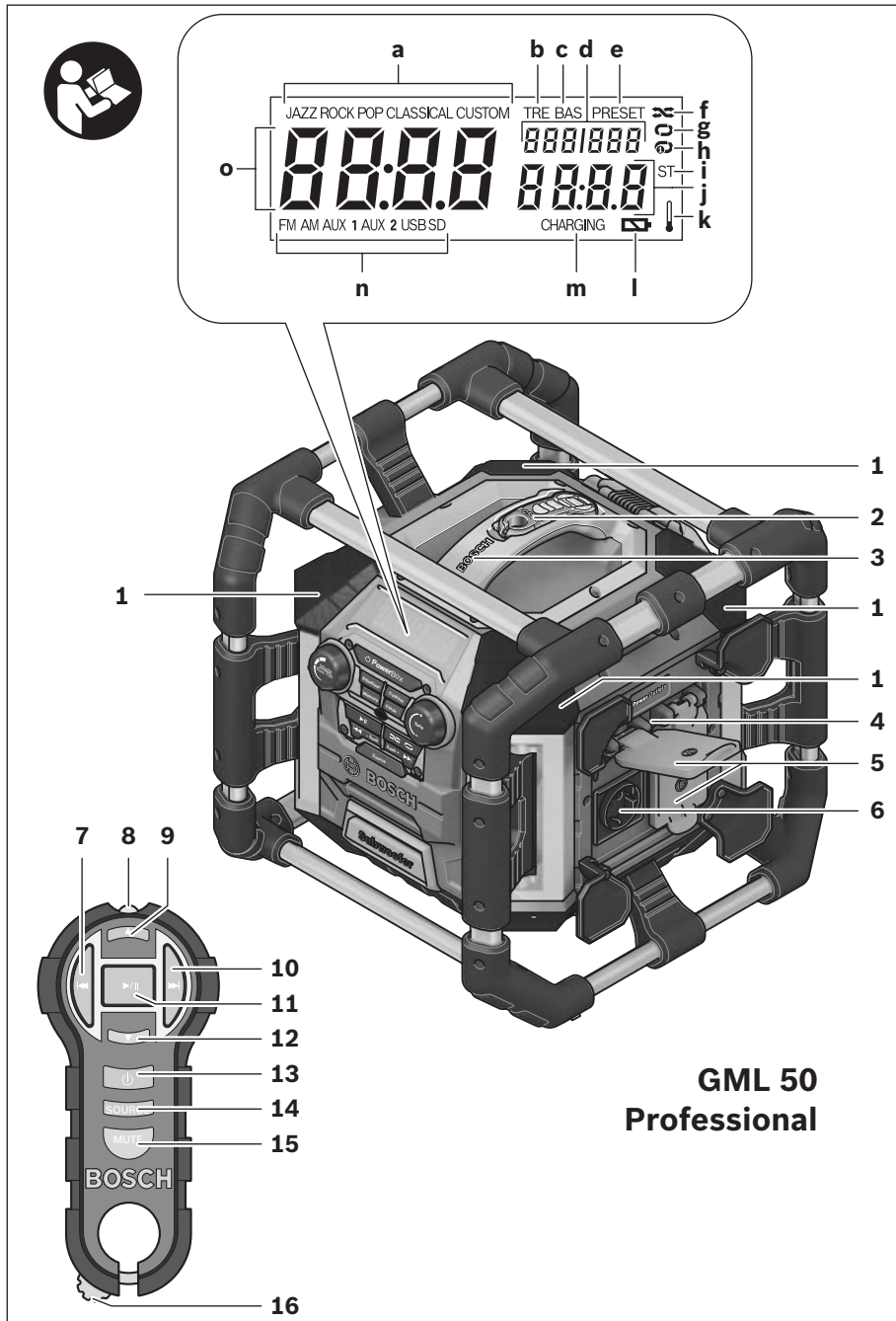

**GML 50  
Professional**

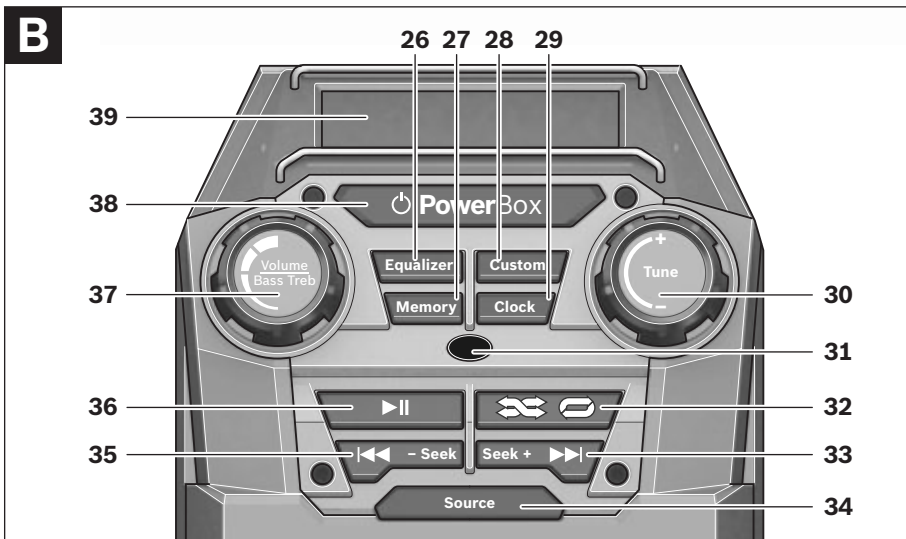
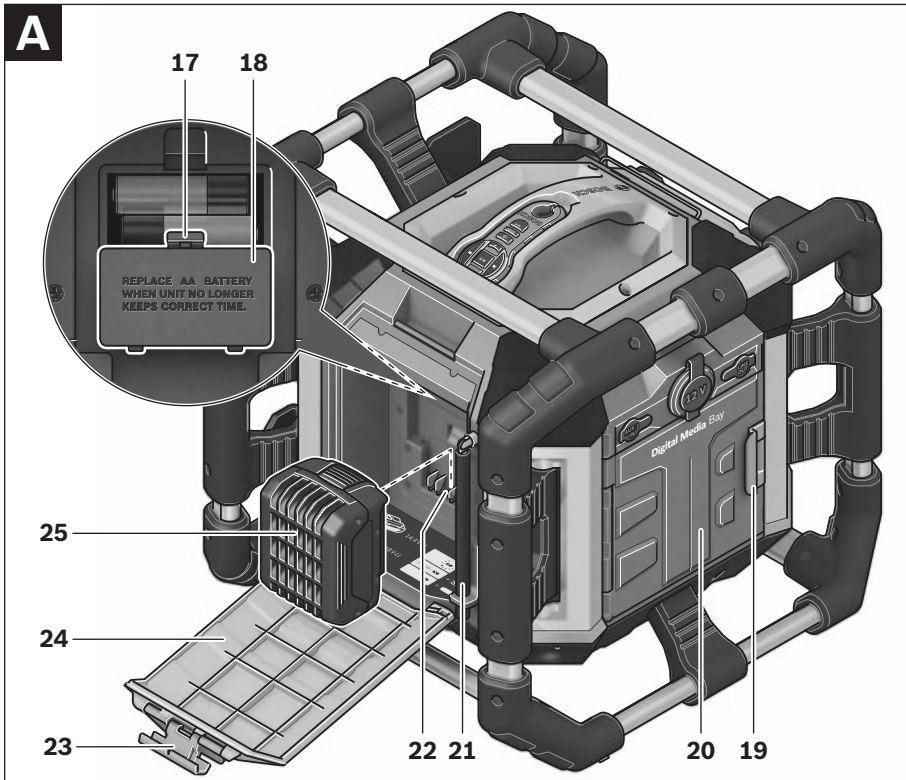

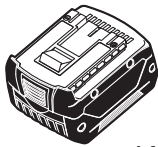
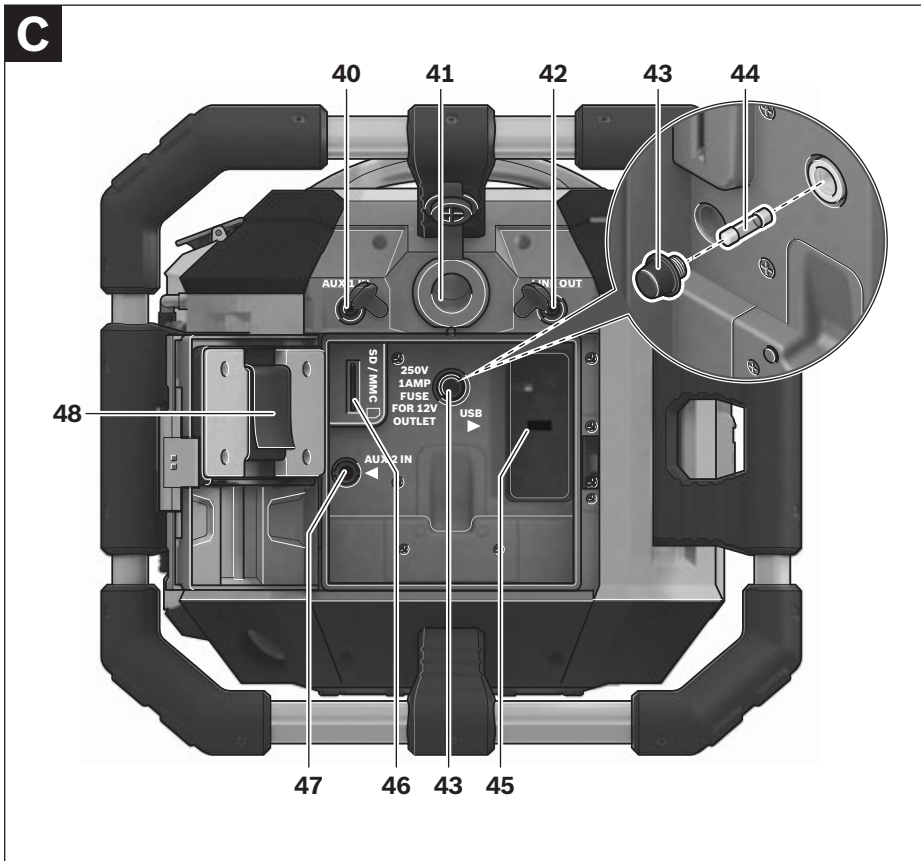

**14,4 V (Li-Ion)**

2 607 336 150 (1,3 Ah)  
 2 607 336 078 (2,6 Ah)  
 2 607 336 224 (3,0 Ah)

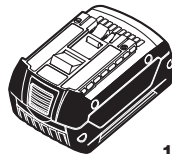

**18 V (Li-Ion)**

2 607 336 170 (1,3 Ah)  
 2 607 336 092 (2,6 Ah)  
 2 607 336 236 (3,0 Ah)

## Safety Notes

**⚠ WARNING** Read all safety warnings and all instructions, including the information on the bottom side of the radio charger.

Failure to follow the warnings and instructions may result in electric shock, fire and/or serious injury.

**Save all safety warnings and instructions for future reference.**

The term “radio charger” used in the safety notes, refers to mains-powered radio chargers (with mains cable) and to battery-operated radio chargers (without mains cable).

- ▶ **Keep work area clean and well lit.** Cluttered or dark areas invite accidents.
- ▶ **The plug of the radio charger must match the outlet. Never modify the plug in any way. Do not use any adapter plugs with earthed (grounded) radio chargers.** Unmodified plugs and matching outlets will reduce the risk of electric shock.
- ▶ **Do not misuse the cord to carry the radio charger, hang it up, or for pulling the plug out of the outlet. Keep the cord away from heat, oil, sharp edges or moving parts.** Damaged or entangled cords increase the risk of electric shock.
- ▶ **When operating the radio charger outdoors, only use extension cords suitable for outdoor use.** Use of a cord suitable for outdoor use reduces the risk of electric shock.
- ▶ **When operating the radio charger in damp environments is unavoidable, use a residual current device (RCD).** The use of a residual current device (RCD) reduces the risk of electric shock.
- ▶ **Connect the radio charger to a mains supply that is properly connected to earth.** Socket and extension cord must have an operative protective conductor.
- ▶ **Completely unwind the mains cable when operating the radio charger via mains supply.** Otherwise the mains cable can heat up.
- ▶ **Take care that the mains plug can be pulled at any time.** The mains plug is the only possibility to disconnect the radio charger from the mains supply.
- ▶ **Protect the radio charger from rain and moisture.** The penetration of water into the radio charger increases the risk of an electric shock.
- ▶ **Do not charge the batteries of other manufacturers.** The battery charger is suitable only for charging Bosch lithium ion batteries with the voltages listed in the technical data. Otherwise there is danger of fire and explosion.
- ▶ **Keep the radio charger clean.** Contamination may result in danger of electric shock.
- ▶ **Check the radio charger, cord and plug each time before using. Do not use the radio charger when defects are detected. Do not open the radio charger yourself and have it repaired only by qualified personnel using original spare parts.** Damaged radio chargers, cords and plugs increase the risk of electric shock.
- ▶ **Do not operate the radio charger on easily inflammable surfaces (e.g. paper, textiles, etc.) or in inflammable environments.** Fire hazard due to occurring heat build-up of the radio charger during charging.
- ▶ **In case of damage and improper use of the battery, vapours may be emitted. Provide for fresh air and seek medical help in case of complaints.** The vapours can irritate the respiratory system.
- ▶ **Children should be supervised to ensure that they do not play with the radio charger.**
- ▶ **Children or persons with mental or physical limitations may only use the radio charger under supervision or after having been instructed.** A thorough introduction reduces operating errors and injuries.
- ▶ **Do not open the battery.** Danger of short-circuiting.



**Protect the battery against heat, e.g., against continuous intense sunlight, fire, water, and moisture.** Danger of explosion.

- ▶ **When battery pack is not in use, keep it away from other metal objects like paper clips, coins, keys, nails, screws, or other small metal objects that can make a connection from one terminal to another.** Shorting the battery terminals together may cause burns or a fire.
- ▶ **Under abusive conditions, liquid may be ejected from the battery; avoid contact. If contact accidentally occurs, flush with water. If liquid contacts eyes, additionally seek medical help.** Liquid ejected from the battery may cause irritations or burns.
- ▶ **Recharge only with the charger specified by the manufacturer.** A charger that is suitable for one type of battery pack may create a risk of fire when used with another battery pack.
- ▶ **Only use the battery in conjunction with your radio charger and/or a Bosch power tool.** This is the only way to protect the battery against dangerous overload.
- ▶ **Use only original Bosch Professional 14.4 V and 18 V lithium ion batteries.** When using other batteries, e.g. imitations, reconditioned batteries or other brands, there is danger of injury as well as property damage through exploding batteries.
- ▶ **Read and strictly observe the safety warnings and working instructions in the operating instructions of the tools that you connect to the radio charger.**
- ▶ **Products sold in GB only:** Your product is fitted with an BS 1363/A approved electric plug with internal fuse (ASTA approved to BS 1362).  
If the plug is not suitable for your socket outlets, it should be cut off and an appropriate plug fitted in its place by an authorised customer service agent. The replacement plug should have the same fuse rating as the original plug.  
The severed plug must be disposed of to avoid a possible shock hazard and should never be inserted into a mains socket elsewhere.

## Functional Description



**Read all safety warnings and all instructions.** Failure to follow the warnings and instructions may result in electric shock, fire and/or serious injury.

Use the radio charger only when you fully understand and can perform all functions without limitation, or have received appropriate instructions.

## Product Features

The numbering of the product features refers to the illustration of the radio charger on the graphics page.

- 1 Speaker
- 2 Remote control
- 3 Carrying handle
- 4 Control lamp for A/C supply (not for article number 3 601 D29 660)
- 5 A/C outlet cover (not for article number 3 601 D29 660)
- 6 A/C socket outlet (not for article number 3 601 D29 660)
- 7 “|<<” button on the remote control
- 8 Outlet opening for infra-red beam
- 9 Increase volume button
- 10 “>>|” button on the remote control
- 11 Play/pause button on the remote control
- 12 Reduce volume button
- 13 On/Off button for audio operation on the remote control
- 14 “Source” button for audio source on the remote control
- 15 “Mute” button
- 16 Loop-clip button
- 17 Latch of back-up battery lid
- 18 Back-up battery lid
- 19 Locking latch of digital media bay flap
- 20 Digital media bay flap

## 22 | English

- 21 Rod antenna
- 22 Charging compartment
- 23 Locking latch of battery lid
- 24 Battery lid
- 25 Battery\*
- 26 **“Equalizer”** button
- 27 **“Memory”** button
- 28 **“Custom”** button (for manual sound adjustment)
- 29 **“Clock”** button (for setting the time)
- 30 **“Tune”** adjustment knob (for tuning of stations)
- 31 Reception lens for remote control
- 32 Button for random playback/repeat
- 33 **“Seek +/>>|”** button
- 34 **“Source”** button (for selecting an Audio Source)
- 35 **“|<<- Seek”** button
- 36 Play/pause button
- 37 Adjustment knob for volume level (**“Volume”**) and sound (**“Bass/Treb”**)
- 38 On/Off button for audio operation
- 39 Display
- 40 **“AUX 1 IN”** socket
- 41 12 V connection socket
- 42 **“LINE OUT”** socket
- 43 Fuse cap
- 44 Fuse for 12 V connection
- 45 USB port
- 46 SD/MMC slot
- 47 **“AUX 2 IN”** socket
- 48 Holder for external audio sources

**\*Accessories shown or described are not part of the standard delivery scope of the product. A complete overview of accessories can be found in our accessories program.**

### Display elements for audio operation

- a** Equalizer (sound-pre-set) indicator
- b** Changing treble – indicator
- c** Changing bass – indicator
- d** Indicator for volume, memory location for radio station and title (depends on the selected audio source)
- e** Station-memory reception indicator (for radio operation)
- f** Random playback indicator (for SD/MMC card or USB audio source)
- g** Repeat-current-track indicator for all tracks in the current folder/directory (for SD/MMC card or USB audio source)
- h** Repeat-current-track indicator (for SD/MMC card or USB audio source)
- i** Stereo indicator
- j** Indicator of radio frequency/Play duration of current track (depends on the selected audio source)
- k** Temperature warning
- l** Battery inserted indicator
- m** Battery charge indicator
- n** Audio-source indicator
- o** Time indication display



## Technical Data

Radio Charger		GML 50 Professional
Article number		3 601 D29 6..
Back-up batteries		2 x 1.5 V (LR06/AA)
Operating temperature	°C	0...45
Storage temperature	°C	-20...+70
Weight according to EPTA-Procedure 01/2003	kg	11.2
Protection class		⊕/I
Degree of protection		IP 54 (dust and splash water protected)
<b>Audio Operation/Radio</b>		
Operating voltage		
– for mains operation	V	230/110
– for battery operation	V	14.4–18
Rated output of amplifier (for mains operation)	W	50
Reception angle of remote control	°	110
Reception range		
– FM	MHz	87.5–108
– AM	kHz	531–1602
Supported file formats <sup>1)</sup>		MP3, WMA
<b>Battery Charger</b>		
Output voltage (automatic voltage detection)	V=	14.4–18
Charging current	A	0.9
Allowable charging temperature range	°C	0–45
Charging time for battery capacity, approx.		
– 1.3–1.5 Ah	min	90
– 2.6–3.0 Ah	min	180
Number of battery cells		4–10
<b>Remote control</b>		
Working range <sup>2)</sup>	m	7
Battery		1 x 3 V (CR2032)

Please observe the article number on the type plate of your radio charger. The trade names of individual radio chargers can vary.

1) (for SD/MMC card or USB audio source)

2) The working range can be decreased by unfavourable environmental conditions (e.g. direct sun irradiation).



## Assembly

### Power Supply of the Radio Charger

The power supply of the radio charger can take place via the mains supply or via a lithium ion battery inserted in the charging compartment **22**. When the battery is used for power supply, only the functions audio operation and power supply of external devices via the integrated USB connection, are available.

- ▶ **Observe the mains voltage!** For power supply via mains, the voltage of the power source must correspond with the data on the type plate of the radio charger. Radio chargers marked with 230 V can also be operated with 220 V.



### Battery Insertion/Removal (see figure A)



- ▶ **Use only original Bosch Professional 14.4 V and 18 V lithium ion batteries.** Using other batteries can lead to injuries and pose a fire hazard.

**Note:** Use of batteries not suitable for the radio charger can lead to malfunctions of or cause damage to the radio charger.

Open locking latch **23** of the battery lid (“**Charger/Battery Bay**”) and fold out battery lid **24**.

Insert a battery into the charging compartment **22** in such a manner that the connections of the battery face against the connections in the charging compartment **22**, and allow the battery to engage in the charging compartment.

 =  As soon as a battery with sufficient voltage is inserted, the battery inserted indicator **I** appears on the display.

 =  The battery inserted indicator **I** flashes when the battery is low.

To remove the battery **25**, press the release button on the battery and pull it out of the charging compartment **22**.

After inserting or removing the battery, close the battery lid **24**. Lock the battery lid by engaging the locking latch **23** in the housing and then pressing down.

- ▶ **If required, wear protective gloves when removing the battery.** The battery can heat up considerably when charging.

### Inserting/Replacing the Back-up Battery (see figure A)

In order to store the time in the radio charger, back-up batteries have to be inserted. Using alkali-manganese batteries is recommended for this purpose.

Open locking latch **23** of the battery lid (“**Charger/Battery Bay**”) and fold out battery lid **24**.

Remove the battery **25**, if required.

To open the back-up battery lid **18**, press on the latch **17** and remove the back-up battery lid. Insert the back-up batteries. When inserting, pay attention to the correct polarity according to the representation on the inside of the back-up battery compartment.

Mount the back-up battery lid **18** again.

**“REPLACE AA BATTERY WHEN UNIT NO LONGER KEEPS CORRECT TIME”:** Replace the back-up batteries when the radio charger no longer stores the time.

Always replace all batteries at the same time. Only use batteries from one brand and with the identical capacity.

- ▶ **Remove the back-up batteries from the radio charger when not using it for longer periods.** When storing for longer periods, the back-up batteries can corrode and discharge themselves.

## Operation

- ▶ **Protect the radio charger against moisture and direct sunlight.**

### Audio Operation (see figures B and C)

Some audio operation functions can also be controlled via the remote control (see “Remote control”, page 27).

### Switching Audio Operation On/Off

To **switch on** audio operation (radio and external playback devices), press the On/Off button **38**. The display **39** goes on and the last set audio source after switching off is activated.

When the radio charger is in the energy saving mode (see “Energy Saving Mode”, Page 30), press the On/Off button **38** twice to switch on audio operation.

To **switch off** audio operation, press the On/Off button **38** again. The current audio source setting is stored.

### Adjusting the Volume

To increase the volume, turn the “**Volume**” **37** adjustment knob clockwise; to reduce the volume, turn the adjustment knob anticlockwise. The volume setting (value between 0 and 20) appears for a few seconds in indicator **d** on the display.

Before adjusting or changing a radio station, set the volume to a lower setting; before starting an external audio source, set the volume to medium.

### Adjusting the Sound

An equalizer is integrated in the radio charger for optimal sound reproduction.

The treble and bass setting can be manually changed or sound pre-sets for various music styles can be used. The following pre-programmed settings are available: “**JAZZ**”, “**ROCK**”, “**POP**” and “**CLASSICAL**” apart from the individually programmable setting “**CUSTOM**”.

To select one of the stored **sound pre-sets**, press the “**Equalizer**” button **26** until the desired setting is indicated in indicator **a** on the display.

#### Changing the “CUSTOM” Setting:

- Press the “**Custom**” button **28** once. The “**BAS**” indicator **c** flashes on the display and the stored bass level flashes in indicator **d**.
- Set the desired bass level (value between 0 and 10). To increase the bass level, turn the “**Bass/Treb**” adjustment knob **37** clockwise; to reduce the bass level, turn the adjustment knob anticlockwise.

- To store the set bass level, press the “**Custom**” button **28** a second time. The “**TRE**” indicator **b** flashes in the display for the following treble adjustment, and the stored treble value flashes in indicator **d**.
- Set the desired treble level (value between 0 and 10). To increase the treble level, turn the “**Bass/Treb**” adjustment knob **37** clockwise; to reduce the treble level, turn the adjustment knob anticlockwise.
- To store the set treble level, press the “**Custom**” button **28** a third time.

### Selecting an Audio Source

To select an audio source, press the “**Source**” button **34** until indicator **n** for the desired internal audio source (see “Setting/Storing Radio Stations”, page 26) or external audio source (see “Connecting External Audio Sources”, page 26) appears in the display:

- “**FM**”: FM radio,
- “**AM**”: AM radio,
- “**AUX 1**”: External audio source (e.g. CD player) via the 3.5 mm socket **40** on the side,
- “**AUX 2**”: External audio source (e.g. MP3 player) via the 3.5 mm socket **47** in the digital media bay,
- “**USB**”: External audio source (e.g. USB stick) via the USB port **45**,
- “**SD**”: External audio source (SD/MMC card) via the SD/MMC slot **46**.

### Setting the Rod Antenna

The radio charger is provided with a mounted rod antenna **21**. For radio operation, point the rod antenna toward the direction that enables the best reception.

When the reception is insufficient, position the radio charger at a different location that enables better reception.

**Note:** When operating the radio charger in the direct vicinity of radio-communication equipment or radio transceivers, the radio reception can be subject to interference.

If the rod antenna **21** should become loose, tighten it directly at the housing by turning in clockwise direction.

### Setting/Storing Radio Stations

Press the **“Source”** button **34** until **n “FM”** is indicated for the ultra-short wave reception range or **“AM”** for the medium wave reception range.

To **set a certain radio frequency**, turn the **“Tune”** adjustment knob **30** clockwise to increase the frequency, and anticlockwise to decrease it. During setting, the frequency is indicated in display section **o**, then in **j**.

To **scan for radio stations with a high signal strength**, press and briefly hold the **“- Seek”** button **35** to scan down and the **“Seek +”** button **33** to scan up the frequency scale. The frequency of the found radio station is briefly indicated in display **o** and then in **j**.

When the reception of a suitable signal is sufficiently strong, the radio charger automatically switches to stereo reception. The indicator for stereo reception **i** appears on the display.

To **store a set station**, press the **“Memory”** button **27**. The **“PRESET”** indicator **e** flashes in the display and the number of the last preset in **d**. To select a preset, press the **“- Seek”** button **35** to scan down and the **“Seek +”** button **33** to scan up, until the desired preset is displayed in indicator **d**. Press the memory button **27** again to store the set station as the selected preset. The indicators **e** and **d** no longer flash.

A total of 20 FM and 10 AM stations can be preset. Please note that an already occupied preset is overwritten when a new radio station is assigned to it.

For **playback of a preset station**, briefly press the **“- Seek”** button **35** to scan down or the **“Seek +”** button **33** to scan up, until the desired preset is displayed in indicator **d** and **“PRESET”** is displayed in **e**.

### Connecting External Audio Sources (see figure C)

Apart from the integrated radio, various external audio sources can be played.

**AUX-In connection 1:** The AUX-In connection 1 is particularly suitable for audio sources to be placed outside of the digital media bay (e.g. a CD player). Remove the protective cap of the **“AUX 1 IN”** socket **40** and insert the 3.5 mm

plug of the provided or of another matching AUX cable into the socket. Connect the AUX cable to an appropriate audio source.

After removing the AUX cable, reattach the protective cap of the **“AUX 1 IN”** socket **40** to protect against dirt/debris.

For external audio sources via the following connections, open locking latch **19** and open lid **20** of the **“Digital Media Bay”**.

- **SD/MMC connection:** Insert a SD or MMC card into the SD/MMC slot **46**. The labelling of the card must face toward the fuse cap **43**. Playback of the card can be started as soon as the track number as well as the number of available tracks on the card are displayed in indicator **d**. To remove the card, briefly press on the card, which is then ejected.
- **USB connection:** Insert a USB stick (or the USB plug of an appropriate audio source) into USB port **45**. Playback of the USB stick can be started as soon as the track number as well as the number of available tracks on the stick are displayed in indicator **d**. To remove the USB stick, pull it out of the USB port.
- **AUX-In connection 2:** AUX-In connection 2 is particularly suitable for audio sources that can be placed inside of the digital media bay (e.g. a MP3 player). Insert the 3.5 mm plug of the provided AUX cable into the **“AUX 2 IN”** socket **47**. Connect the AUX cable to an appropriate audio source.

When small enough, the connected external audio source can be fastened into the digital media bay using the Velcro strap of the holder **48**.

After connecting the external audio source, close the Media/connections flap **20** if possible, to protect against damage and debris.

For playback of the connected audio source, press the **“Source”** button **34** until the indicator **n** for the desired audio source appears on the display.

### Controlling External Audio Sources

For audio sources connected via the SD/MMC slot **46** or the USB port **45**, playback can be controlled via the radio charger. The number of the selected track is displayed at the left of indicator **d** and the number of available tracks on the right.

#### Play/Pause:

- To start playback, press the play/pause button **36**. The playing time of the current track is displayed in indicator **j**.
- To interrupt or continue the playback, press the play/pause button **36** again. The current playing time flashes in indicator **j**.

#### Selecting Tracks:

- To select a track, press the “- Seek” button **35** to scan down or the “Seek +” button **33** to scan up, until the number of the desired track is displayed on indicator **d**.
- To start playback, press the play/pause button **36**.

#### Random Playback/Repeat:

- For random playback of all tracks on the card or the USB stick, press the random playback/repeat button **32** once. The indicator **f** appears on the display.
- To repeat all tracks in the current folder/directory, press the random playback/repeat button **32** a second time. The indicator **g** appears on the display.

**Note:** Only in this function, the number of the current folder/directory on the card or USB stick will appear on the right-hand side of indicator **d**. To change the folder/directory, you have to return to the normal playback first and select a track from the desired folder/directory.

- To repeat only the current track, press the random playback/repeat button **32** a third time. The indicator **h** appears on the display.
- To return to normal playback mode, press the random playback/repeat button **32** a fourth time, so that none of the indicators **f**, **g** or **h** appear on the display.
- To start playback, press the play/pause button **36**.

### Connecting External Audio Playback (see figure C)

The current audio signal of the radio charger can also be transferred to other playback devices (e.g. amplifier and speakers).

Remove the protective cap of the “LINE OUT” socket **42** and insert the 3.5 mm plug of a matching AUX cable into the socket. Connect an appropriate playback device to the AUX cable. After removing the AUX cable, reattach the protective cap of the “LINE OUT” socket **42** to protect against dirt/debris.

### Remote control

- ▶ **Have the remote control repaired only through a qualified repair person and only using identical replacement parts.** This will ensure that the functionality of the remote control is maintained.
- ▶ **Do not operate the remote control in explosive atmospheres, such as in the presence of flammable liquids, gases or dusts.** Sparks can be created in the remote control which may ignite the dust or fumes.

#### Initial Operation

- ▶ **Protect the remote control against moisture and direct sunlight.**
- ▶ **Do not subject the remote control to extreme temperatures or variations in temperature.** As an example, do not leave it in vehicles for longer periods. In case of large variations in temperature, allow the remote control to adjust to the ambient temperature before putting it into operation.

The remote control remains ready for operation as long as battery with sufficient voltage is inserted.

Position the radio charger in such a manner that the signals from outlet opening **8** of the remote control can directly reach reception lens **31** on the radio charger. When the remote control cannot be pointed directly against a reception lens, the working range is reduced. By reflecting the signal (e.g. against walls), the working range can be improved even for indirect signals.

The remote control **2** can be stored in carrying handle **3**. When using the remote control, you can fasten it e.g., to a belt loop by opening loop-clip button **16** and attaching the remote control.

## Functions

Independent of the audio source:

- To **switch the audio operation on and off**, press button **13** on the remote control.
- To **switch the sound on and off**, press button **"Mute" 15** on the remote control.
- To increase the **volume**, press button **9**; to reduce the volume, press button **12**.
- To **change the audio source**, press button **"Source" 14**.

For radio operation:

- To **select a radio station** with a lower frequency, press the **7** button until the desired frequency is found.
- To **select a radio station** with a higher frequency, press the **10** button until the desired frequency is found.

When controlling audio sources connected via the SD/MMC slot **46** or the USB port **45**:

- To start, interrupt or continue the **playback of a track**, press the play/pause button **11**.
- To **select a track**, press the **7** or **10** button.

## Battery Replacement

To replace the battery, unscrew the screw of the battery compartment on the backside of the remote control and remove the battery lid.

When inserting the new battery, pay attention to the correct polarity. Screw on the battery lid again.

- ▶ **Replace the battery only with a new battery of the same type.** Danger of explosion when inserting other battery types.
- ▶ **Remove the battery from the remote control when not using it for longer periods.** When storing for longer periods, the battery can corrode and discharge itself.
- ▶ **Keep the battery away from children.** Children could swallow the battery and cause a hazardous situation for their health.

## Battery Charging (see figure A)

The charge procedure begins as soon as the mains plug of the radio charger is plugged into a socket outlet and a battery **25** is inserted into the charging compartment **22** (see "Battery Insertion/Removal", page 24).



During the charging procedure, the **"CHARGING"** indicator **m** flashes on the display. The **"CHARGING"** indicator goes out when the battery is fully charged.

Due to the intelligent charging method, the charging condition of the battery is automatically detected and the battery is charged with the optimum charging current, depending on battery temperature and voltage.

This saves the battery and ensures that it is always fully charged when in the radio charger.

The charged battery **25** can be removed from the charging compartment **22** or (when inserted in the charging compartment) be used for power supply during audio operation.

- ▶ **If required, wear protective gloves when removing the battery.** The battery can heat up considerably when charging.

## Power Supply of External Devices

The power supply of external devices via the 12 V and the AC connection is possible only when the radio charger is connected to mains, and not via the inserted battery.

When the radio charger is connected to the mains supply, this is confirmed by the lit green control lamp **4**.

### USB Connection

With the USB connection, it is possible to operate and charge most devices whose power supply is possible via USB (e.g., various mobile phones).

Disengage locking latch **19** and open the digital media bay flap **20**. Connect the USB plug of the external device to the USB port **45** of the radio charger. To start the charging procedure, the external device must possibly also be selected as the audio source on the radio charger.

### 12 V Connection (see figure C)

With the 12 V connection socket, you can operate an external electrical device with a 12 V plug and a max. current consumption of 1 A.

Remove the protective cap of the 12 V connection socket **41**. Insert the plug of the external electrical device into the 12 V socket outlet.

The 12 V connection socket is protected by a **fuse 44**. When no voltage is given after connecting an external device, disengage locking latch **19** and open the digital media bay flap **20**. Unscrew the fuse cap **43** and check if the inserted fuse **44** has blown. If the fuse has blown, insert a new fine-wire fuse (5 x 20 mm, 250 V max. voltage, 1 A rated current and quick-acting tripping characteristic). Screw on and tighten fuse cap **43** again.

**Note:** Use only 1 A fuses for a max. voltage of 250 V ("**250V 1A FUSE FOR 12V OUTLET**").

When using other fuses, the radio charger can become damaged.

The 12 V connection is also protected with an **internal thermal fuse**, which is blown/actuated when overheated. The fuse is automatically reset after the radio charger has cooled down.

After removing the external plug, reattach the protective cap of the 12 V socket outlet **41** to protect against dirt/debris.

### A/C Connection ("Power Outlets") (not for article number 3 601 D29 660)

Further external electrical devices/tools can be operated via the A/C outlets. The socket outlets can vary in consideration of country-specific standards.

The total maximum permitted current consumption of all connected electrical devices/tools must not exceed the value in the following table (also see the labeling on the housing under the outlet cover **5**):

Article number	Total max. current consumption (in A)
3 601 D29 600	15
3 601 D29 630	9
3 601 D29 670	12
3 601 D29 6W0	15
3 601 D29 6X0	9

Open one of the A/C outlet covers **5** and insert the plug of an external electrical device into a socket outlet **6** of the radio charger.

### Time Indication

The radio charger is equipped with a time indication with separate power supply. When back-up batteries with sufficient capacity are inserted in the back-up battery compartment (see "Inserting/Replacing the Back-up Battery", page 24), the time can be stored even when the radio charger is disconnected from the A/C power supply or the battery.

### Setting the Time

- To set the time, press and hold the "**Clock**" button **29** until the hours indication flashes in the time indication display **o**.
- Press the "**Seek +**" button **33** or the "**- Seek**" button **35** until the correct hour setting is indicated.
- Press the "**Clock**" button again, so that the minutes indication flashes in the time indication display **o**.
- Press the "**Seek +**" button **33** or the "**- Seek**" button **35** until the correct minute setting is indicated.
- Press the "**Clock**" button a third time to store the time setting.

## 30 | English

**Energy Saving Mode**

To save energy, you can switch the time indication in display **39** off.

For this, press and hold the On/Off button **38** when switching off audio operation (see “Switching Audio Operation On/Off”, page 25), until there is no indication on the display.

To switch the time indication on again, press the On/Off button **38** once.

**Working Advice****Temperature Monitoring for Battery Operation**

When the radio charger is operated only via battery (no mains supply), the battery temperature is monitored.

- When the battery temperature is below  $-10\text{ }^{\circ}\text{C}$  or above  $50\text{ }^{\circ}\text{C}$ , the temperature warning **k** flashes on the display.
- When the battery temperature is above  $70\text{ }^{\circ}\text{C}$ , the radio charger automatically switches off to protect the battery. When the battery has cooled down, the radio charger can be put into operation again.

**Recommendations for Optimal Handling of the Battery**

Protect the battery against moisture and water.

Store the battery only within a temperature range between  $0\text{ }^{\circ}\text{C}$  and  $45\text{ }^{\circ}\text{C}$ . As an example, do not leave the battery in the car in summer.

A battery that is new or has not been used for a longer period does not develop its full capacity until after approx. 5 charging/discharging cycles.

A significantly reduced working period after charging indicates that the battery is used and must be replaced.

Observe the notes for disposal.

**Troubleshooting – Causes and Corrective Measures**

Cause	Corrective Measure
<b>Radio charger inoperative</b>	
No power supply	Properly insert mains plug or battery (completely)
Radio charger too warm or too cold	Wait until the radio charger has reached operating temperature
<b>Radio charger inoperative on A/C power supply</b>	
Mains socket faulty	Use another socket
Mains plug or cord defective	Check mains plug and cable and have repaired as required
<b>Radio charger inoperative on DC power supply</b>	
Battery contacts contaminated	Clean the battery contacts (e.g. by inserting and removing the battery several times) or replace the battery
Battery defective	Replace the battery
Battery too warm or too cold (temperature warning <b>k</b> flashing or radio charger switches off)	Wait until of the battery has reached operating temperature
<b>Battery charging or power supply to external devices inoperative</b>	
Mains plug not plugged-in	Plug mains plug in (completely)
Battery not inserted (correctly) for charging	Have battery engage properly in charging compartment



Cause	Corrective Measure
<b>12 V power supply inoperative</b>	
No fuse <b>44</b> inserted	Insert fuse <b>44</b>
Fuse <b>44</b> blown	Replace fuse <b>44</b>
Internal thermal fuse blown/actuated	Remove external device and allow radio charger to cool down
<b>Radio charger suddenly inoperative</b>	
Mains plug or battery not properly or completely plugged in	Plug in mains plug or battery properly or completely
Software error	To reset the software, pull the mains plug and remove the battery; wait 30 seconds, then insert mains plug and battery again
<b>Bad radio reception</b>	
Interference from other devices or insufficient set-up location	Position radio charger at other location with better reception
Rod antenna not optimally directed	Turn/change position of rod antenna
<b>Time indication faulty</b>	
Back-up batteries of clock empty	Replace back-up batteries
Back-up batteries incorrectly inserted (wrong polarity)	Insert back-up batteries correctly
<b>Remote control inoperative</b>	
Battery of remote control empty	Replace battery of remote control
Battery of remote control incorrectly inserted (wrong polarity)	Insert battery of remote control correctly
Signal of remote control does not reach reception lens <b>31</b>	Turn radio charger so that reception lens <b>31</b> faces toward the remote control

When the corrective measures do not eliminate an error, please contact an authorised service agent for Bosch power tools.

## Maintenance and Service

### Maintenance and Cleaning

► **The mains cable is provided with a special safety connection and may only be replaced by an authorised service agent for Bosch power tools.**

For safe and proper working, always keep the radio charger and the remote control clean.

Do not immerse the remote control into water or other fluids.

Wipe off debris using a moist and soft cloth. Do not use any cleaning agents or solvents.

If the radio charger or the remote control should fail despite the care taken in manufacture and testing, repair should be carried out by an authorised customer services agent for Bosch power tools.

In all correspondence and spare parts orders, please always include the 10-digit article number given on the type plate of the radio charger.

### After-sales Service and Customer Assistance

Our after-sales service responds to your questions concerning maintenance and repair of your product as well as spare parts. Exploded views and information on spare parts can also be found under:

**www.bosch-pt.com**

Our customer service representatives can answer your questions concerning possible applications and adjustment of products and accessories.

#### Great Britain

Robert Bosch Ltd. (B.S.C.)  
P.O. Box 98  
Broadwater Park  
North Orbital Road  
Denham  
Uxbridge  
UB 9 5HJ  
Tel. Service: +44 (0844) 736 0109  
Fax: +44 (0844) 736 0146  
E-Mail: boschservicecentre@bosch.com

#### Ireland

Origo Ltd.  
Unit 23 Magna Drive  
Magna Business Park  
City West  
Dublin 24  
Tel. Service: +353 (01) 4 66 67 00  
Fax: +353 (01) 4 66 68 88

#### Australia, New Zealand and Pacific Islands

Robert Bosch Australia Pty. Ltd.  
Power Tools  
Locked Bag 66  
Clayton South VIC 3169  
Customer Contact Center  
Inside Australia:  
Phone: +61 (01300) 307 044  
Fax: +61 (01300) 307 045  
Inside New Zealand:  
Phone: +64 (0800) 543 353  
Fax: +64 (0800) 428 570  
Outside AU and NZ:  
Phone: +61 (03) 9541 5555  
www.bosch.com.au

#### Republic of South Africa

##### Customer service

Hotline: +27 (011) 6 51 96 00

##### Gauteng – BSC Service Centre

35 Roper Street, New Centre  
Johannesburg  
Tel.: +27 (011) 4 93 93 75  
Fax: +27 (011) 4 93 01 26  
E-Mail: bsctools@icon.co.za

##### KZN – BSC Service Centre

Unit E, Almar Centre  
143 Crompton Street  
Pinetown  
Tel.: +27 (031) 7 01 21 20  
Fax: +27 (031) 7 01 24 46  
E-Mail: bsc.dur@za.bosch.com

##### Western Cape – BSC Service Centre

Democracy Way, Prosperity Park  
Milnerton  
Tel.: +27 (021) 5 51 25 77  
Fax: +27 (021) 5 51 32 23  
E-Mail: bsc@zsd.co.za

##### Bosch Headquarters

Midrand, Gauteng  
Tel.: +27 (011) 6 51 96 00  
Fax: +27 (011) 6 51 98 80  
E-Mail: rbsa-hq.pts@za.bosch.com

#### People's Republic of China

Website: www.bosch-pt.com.cn

##### China Mainland

Bosch Power Tools (China) Co., Ltd.  
567, Bin Kang Road  
Bin Jiang District 310052  
Hangzhou, P.R.China  
Service Hotline: 400 8 26 84 84  
Tel.: +86 (571) 87 77 43 38  
Fax: +86 (571) 87 77 45 02

#### HK and Macau Special Administrative Regions

Robert Bosch Hong Kong Co. Ltd.  
21st Floor, 625 King's Road  
North Point, Hong Kong  
Customer Service Hotline: +852 (21) 02 02 35  
Fax: +852 (25) 90 97 62  
E-Mail: info@hk.bosch.com  
www.bosch-pt.com.cn

**Indonesia**

PT. Multi Tehaka  
 Kawasan Industri Pulogadung  
 Jalan Rawa Gelam III No. 2  
 Jakarta 13930  
 Indonesia  
 Tel.: +62 (21) 46 83 25 22  
 Fax: +62 (21) 46 82 86 45/68 23  
 E-Mail: sales@multitehaka.co.id  
 www.multitehaka.co.id

**Philippines**

Robert Bosch, Inc.  
 28th Floor Fort Legend Towers,  
 3rd Avenue corner 31st Street,  
 Fort Bonifacio Global City,  
 1634 Taguig City, Philippines  
 Tel.: +63 (2) 870 3871  
 Fax: +63 (2) 870 3870  
 matheus.contiero@ph.bosch.com  
 www.bosch-pt.com.ph

Bosch Service Center:  
 9725-27 Kamagong Street  
 San Antonio Village  
 Makati City, Philippines  
 Tel.: +63 (2) 899 9091  
 Fax: +63 (2) 897 6432  
 rosalie.dagdagan@ph.bosch.com

**Malaysia**

Robert Bosch (S.E.A.) Pte. Ltd.  
 No. 8A, Jalan 13/6  
 G.P.O. Box 10818  
 46200 Petaling Jaya  
 Selangor, Malaysia  
 Tel.: +60 (3) 7966 3194  
 Fax: +60 (3) 7958 3838  
 cheehoe.on@my.bosch.com  
 Toll-Free: 1800 880 188  
 www.bosch-pt.com.my

**Thailand**

Robert Bosch Ltd.  
 Liberty Square Building  
 No. 287, 11 Floor  
 Silom Road, Bangrak  
 Bangkok 10500  
 Tel.: +66 (2) 6 31 18 79 – 18 88 (10 lines)  
 Fax: +66 (2) 2 38 47 83  
 Robert Bosch Ltd., P. O. Box 2054  
 Bangkok 10501, Thailand

Bosch Service – Training Centre  
 2869-2869/1 Soi Ban Kluay  
 Rama IV Road (near old Paknam Railway)  
 Prakanong District  
 10110 Bangkok  
 Thailand  
 Tel.: +66 (2) 6 71 78 00 – 4  
 Fax: +66 (2) 2 49 42 96  
 Fax: +66 (2) 2 49 52 99

**Singapore**

Robert Bosch (SEA) Pte. Ltd.  
 11 Bishan Street 21  
 Singapore 573943  
 Tel.: +65 6571 2772  
 Fax: +65 6350 5315  
 leongheng.leow@sg.bosch.com  
 Toll-Free: 1800 333 8333  
 www.bosch-pt.com.sg

**Vietnam**

Robert Bosch Vietnam Co. Ltd  
 10/F, 194 Golden Building  
 473 Dien Bien Phu Street  
 Ward 25, Binh Thanh District  
 84 Ho Chi Minh City  
 Vietnam  
 Tel.: +84 (8) 6258 3690 ext. 413  
 Fax: +84 (8) 6258 3692  
 hieu.lagia@vn.bosch.com  
 www.bosch-pt.com

### Transport

Dispatch batteries only when the housing is undamaged. Tape or mask off open contacts and pack up the battery in such a manner that it cannot move around in the packaging. When dispatching lithium-ion batteries, compulsory labeling may be required. Please observe the respective national regulations.

### Disposal

The radio charger, accessories and packaging should be sorted for environmental-friendly recycling.

Do not dispose of the radio charger, remote control and battery pack/batteries into household waste!

#### Only for EC countries:



According to the European Guideline 2002/96/EC, power tools that are no longer usable, and according to the European Guideline 2006/66/EC, defective or used battery packs/batteries, must be collected separately and disposed of in an environmentally correct manner.

Batteries no longer suitable for use can be directly returned at:

#### Great Britain

Robert Bosch Ltd. (B.S.C.)  
 P.O. Box 98  
 Broadwater Park  
 North Orbital Road  
 Denham  
 Uxbridge  
 UB 9 5HJ  
 Tel. Service: +44 (0844) 736 0109  
 Fax: +44 (0844) 736 0146  
 E-Mail: boschservicecentre@bosch.com

### Battery packs/batteries:



#### Li-ion:

Please observe the instructions in section "Transport", page 34.

**Subject to change without notice.**