

MV 4
MV 4 Premium

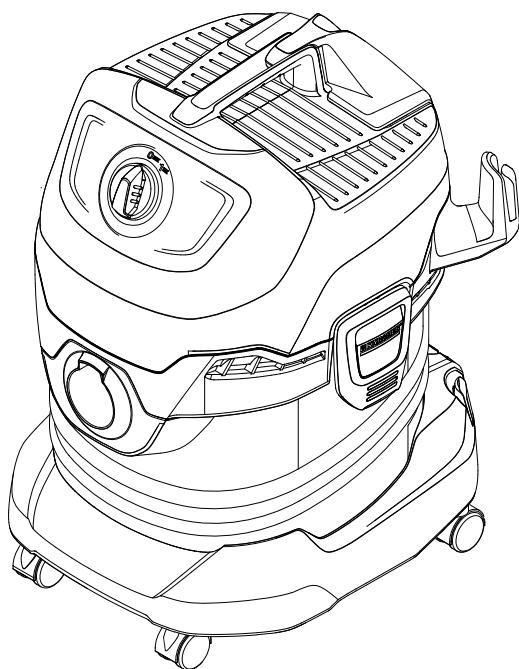

Operating Instructions

Before first use of the unit
read these operating instructions
and act in accordance with them.



Register and win!
www.kärcher.com/register-and-win



59651790 10/13

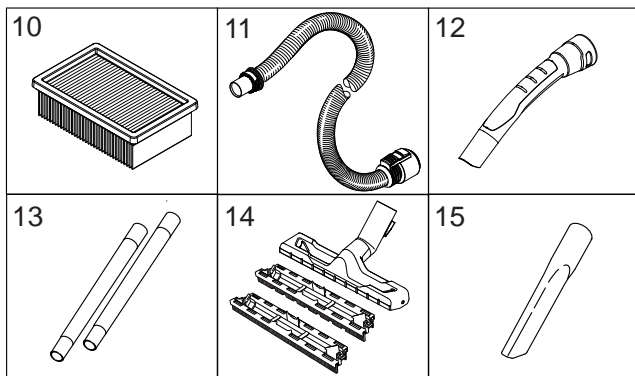
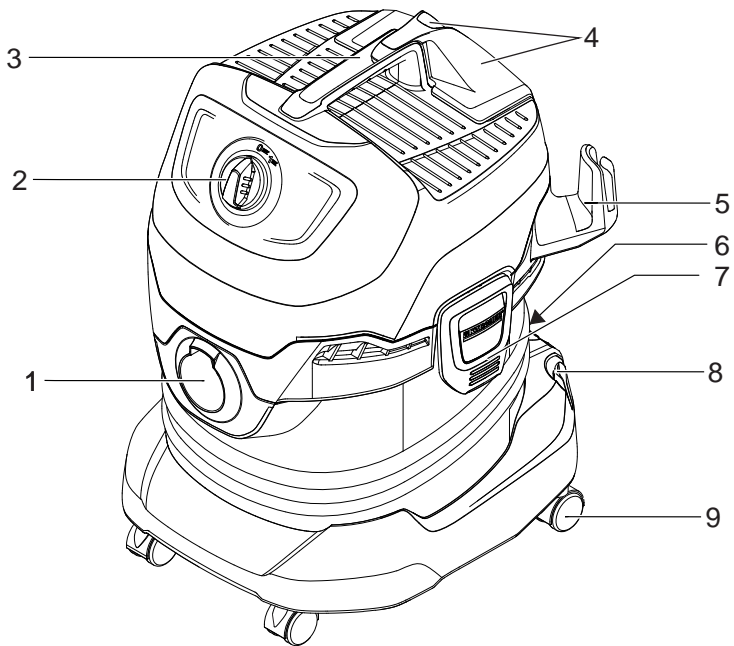

A 1

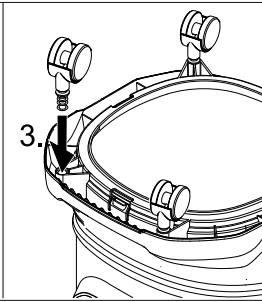
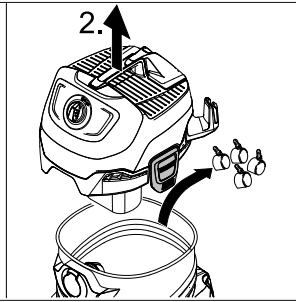
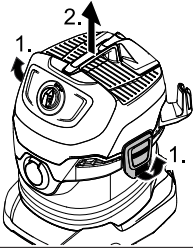

A 2

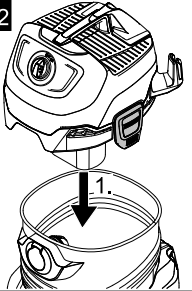

B 1

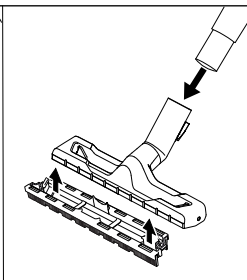
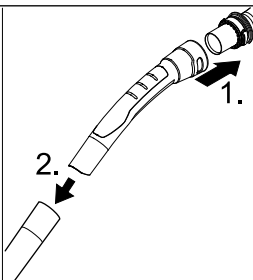
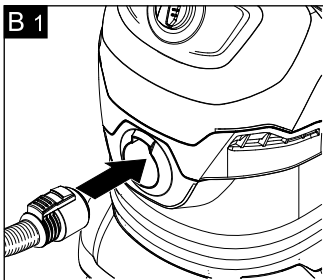

B 2

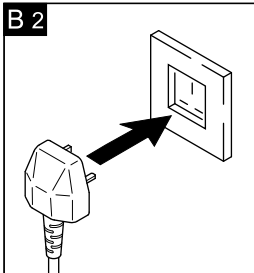

B 3

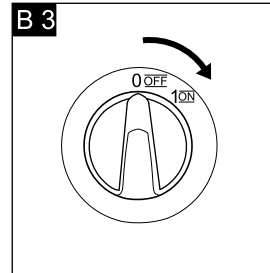

B 4

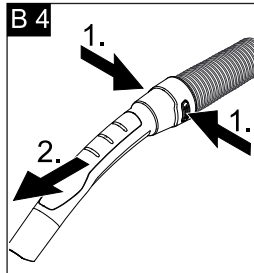

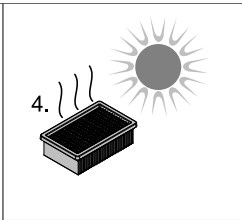
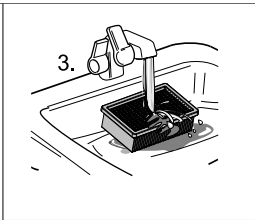
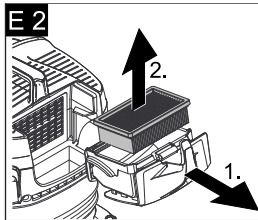
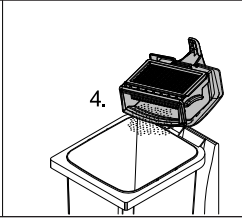
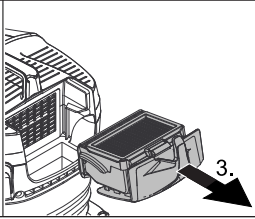
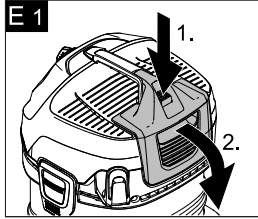
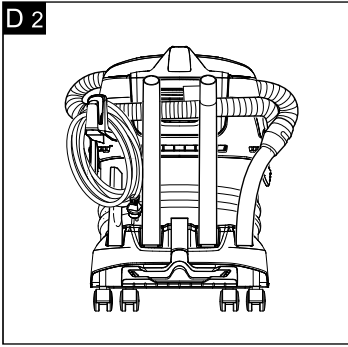
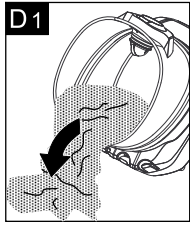
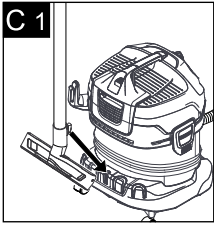

Contents

General notes	5
Safety instructions	6
Description of the Appliance.	7
Operation	9
Maintenance and care	10
Troubleshooting	11
Technical specifications	12

General notes

Dear Customer,



Please read and comply with these original instructions prior to the initial operation of your appliance and store them for later use or subsequent owners.

Proper use

In accordance with the descriptions and the safety information in these operating instructions the appliance is intended for use as a multi-purpose vacuum cleaner.

This appliance has been designed for use in private households and is not intended for commercial use.

- Protect the unit from rain. Do not store outside.
- This device may not be used to suck in ash and soot.

Use the multi-purpose vacuum cleaner only with:

- Original spare parts, accessories and special accessories.

The manufacturer is not responsible for any damages that may occur on account of improper use or wrong operations.

Environmental protection



The packaging material can be recycled. Please do not place the packaging into the ordinary refuse for disposal, but arrange for the proper recycling.



Old appliances contain valuable materials that can be recycled.

■ Please arrange for the proper recycling of old appliances. Please dispose your old appliances using appropriate collection systems.

Disposing the filter

The filter is made from environment-friendly materials.

The filter can therefore be disposed off through the normal household garbage provided you have not sucked in substances that are not permitted to be thrown into household garbage.

Notes about the ingredients (REACH)

You will find current information about the ingredients at:

www.kaercher.com/REACH

Customer Service

Our KÄRCHER branch will be pleased to help you further in the case of questions or faults.

(See address on the reverse)

Ordering spare parts and special attachments

At the end of the operating instructions you will find a selected list of spare parts that are often required.

You can procure the spare parts and the attachments from your dealer or your KÄRCHER branch office.

Warranty

The terms of the guarantee applicable in each country have been published by our respective national distributors. We will repair possible faults on your unit free of charge within the warranty period, insofar as the faults are caused by material defects or defective workmanship. Guarantee claims should be addressed to your dealer or the nearest authorized customer service centre, and supported by documentary evidence of purchase.

Safety instructions

- *This appliance is not intended for use by persons with limited physical, sensory or mental capacities or lacking experience and/or skills, unless such persons are accompanied and supervised by a person in charge of their safety or they have received precise instructions on the use of this appliance and have understood the resulting risks.*
- *Children may only use this appliance if they are over the age of 8 and supervised by a person in charge of their safety, or if they have received instructions on the use of this appliance and have understood the resulting risks.*
- *Children must not play with this appliance.*
- *Supervise children to prevent them from playing with the appliance.*
- *Cleaning and user maintenance must not be performed*

by children without supervision.

- *Keep packaging film away from children - risk of suffocation!*
- *Switch the appliance off after every use and prior to every cleaning/maintenance procedure.*
- *Risk of fire. Do not vacuum up any burning or glowing objects.*
- *The appliance may not be used in areas where a risk of explosion is present.*

△ Electrical connection

The appliance may only be connected to alternating current. The voltage must correspond with the type plate on the appliance.

△ Risk of electric shock

Never touch the mains plug and the socket with wet hands. Do not pull the plug from the socket by pulling on the connecting cable.

Check the power cord with mains plug for damage before every use. If the power cord is damaged, please arrange immediately for the exchange by an authorized customer service or a skilled electrician.

To avoid accidents due to electrical faults we recommend the use of sockets with a line-side current-limiting circuit breaker (max. 30 mA nominal tripping current).

⚠ Warning

Certain materials may produce explosive vapours or mixtures when agitated by the suction air! Never vacuum up the following materials:

- *Explosive or combustible gases, liquids and dust particles (reactive dust particles)*
- *Reactive metal dust particles (such as aluminium, magnesium, zinc) in combination with highly alkaline or acidic detergents*
- *Undiluted, strong acids and alkalis*
- *Organic solvents (such as petrol, paint thinners, acetone, heating oil).*

In addition, these substances may cause the appliance materials to corrode.

Symbols in the operating instructions

⚠ Danger

Immediate danger that can cause severe injury or even death.

⚠ Warning

Possible hazardous situation that could lead to severe injury or even death.

Caution

Possible hazardous situation that could lead to mild injury to persons or damage to property.

Description of the Appliance

Illustrations on fold-out page!



- These operating instructions describe the multi-purpose vacuum cleaners listed on the front cover.
- The illustrations show the maximum equipment; depending on the model, there are differences in equipment and supplied accessories.

When unpacking the product, make sure that no accessories are missing and that none of the package contents have been damaged. If you detect any transport damages please contact your dealer.

1 Suction hose connection

Illustration **B.1**

- ➔ To connect the suction hose during vacuuming.

2 ON/OFF switch for appliance

Illustration **B.3**

- ➔ **Position I:** Appliance is switched on.
- Position 0:** Appliance is switched off

3 Carrying handle

- ➔ To carry the appliance or to remove the appliance head after unlocking.

4 Filter cartridge and release key

Illustration **E 1**

Illustration **E 2**

- In order to clean the filter, press the release key, fold out and remove the filter cartridge.

5 Accessory compartment, hook

This accessory compartment allows the storage of suction nozzles and the power cable.

6 Parking position

Illustration **C 1**

- To rest the floor nozzle during work interruptions.

7 Container closure

Illustration **A 1**

- Pull out to open, push in to lock.

8 Accessory storage container

Illustration **D 2**

- This accessory compartment allows the storage of the suction pipes or other accessories.

9 Steering roller

Illustration **A 1**

- The steering rollers are located in the compartment when the appliance is delivered. These must be attached prior to starting up the appliance.

10 Flat fold filter

(already installed in the appliance)

Caution

Always work with an inserted flat pleated filter - during wet as well as dry vacuum cleaning!

11 Suction hose with connecting piece

Illustration **B 1**

- Push the suction hose into the connection on the appliance, it snaps in place.
- In order to disconnect it, push down with your thumb and pull the suction hose out.

Note: Accessories, such as suction brushes (optional) can be directly attached to the connecting piece and thus connected to the suction hose. For convenient working even in tight spaces.

The removable handle can be attached between the accessories and the suction hose if necessary.

See position 12.

Recommendation: In order to vacuum the floor, attach the handle to the suction hose.

12 Removable handle

Illustration **B 1**

→ Connect the handle with the suction hose until it snaps in place.

Illustration **B 4**

→ To remove the handle from the suction hose, press the notch using your thumb and pull off the handle.

Note: Due to removing the handle, accessories can be directly attached to the suction hose.

See position 11.

Recommendation: In order to vacuum the floor, attach the handle to the suction hose.

13 Suction tubes 2 x 0.5 m

Illustration **B 1**

→ Put both suction pipes together and connect them with the handle.

14 Floor nozzle (with inserts)

→ When vacuuming dry dirt off the floor, clip an insert with two brush strips into the floor nozzle.

→ When vacuuming water off the floor, clip an insert with two rubber lips into the floor nozzle.

15 Crevice nozzle

→ For edges, joints, heaters and hard to reach locations.

Operation

Caution

Always work with an inserted flat pleated filter - during wet as well as dry vacuum cleaning!

Before Startup

Illustration **A 1**

Illustration **A 2**

→ Remove the appliance head and take the contents out of the container.

→ Turn the container, press in the swivel casters in the openings at the base of the container till the end-point.

→ Insert and lock the appliance head.

Start up

Illustration **B 1**

→ Connect accessories.

Illustration **B 2**

→ Plug in the main plug.

Illustration **B 3**

→ Turn on the machine.

Dry vacuum cleaning

Caution

Work with a dry flat pleated filter only.

Check the filter for damage prior to installation and replace as necessary.

Vacuum cold ashes only when using a pre-filter.

Order no. basic design: 2.863-139.0,
premium design: 2.863-161.0.

Wet vacuum cleaning

- For vacuuming up moisture or wetness pay attention to the correct floor nozzle insert and connect the corresponding accessories.

⚠ **Caution:**

Do not use a filter bag!

Immediately switch the appliance off if foam forms or liquids escape!

Immediately switch the appliance off or pull the power plug if foam forms or liquids escape!

Note: If the container is full, a float closes the suction opening, and the appliance works at a higher speed. Switch off the appliance immediately, and empty the container.

Interrupting operation

Illustration **B3**

- Turn off the appliance.

Illustration **C1**

- Hook the floor nozzle into the parking position.

Finish operation

- Turn off the appliance and disconnect the mains plug.

Empty the container

Illustration **D1**

- Remove the appliance head and empty the reservoir filled with wet or dry dirt.

Storing the appliance

Illustration **D2**

- Store the accessories and the mains cable on the appliance and store the appliance in dry rooms.

Maintenance and care

⚠ **Danger**

Turn off the appliance and remove the mains plug prior to any care and maintenance work.

Repair works may only be performed by the authorised customer service.

⚠ **Warning**

Do not use abrasives, glass or universal cleaners! Never immerse the appliance in water.

- Clean the appliance and accessory parts made of plastic with a commercial plastic cleaner.
- If required, rinse the container and accessories with water properly and dry them before reuse.

Clean flat fold filter

Recommendation: Clean the filter cartridge after every use.

Illustration **E1**

- Unlock, fold out and remove the filter cartridge, empty dirt from the filter cartridge over a waste bin.
- In order to clean the inserted flat pleated filter, knock the filter cartridge against the edge of the waste bin. It is not necessary to remove the flat pleated filter from the filter cartridge.

If necessary, clean the flat pleated filter separately.

Illustration **E1**

- Unlock, fold out and remove the filter cartridge.

Illustration **E2**

- Remove the flat pleated filter from the filter cartridge and tab it out.
- When necessary, clean under running water only, do not wipe or brush down.

- Allow to dry completely prior to use.
- Finally, reinstall the dry flat pleated filter into the appliance. Insert the filter cartridge into the appliance.

Troubleshooting

Decreasing cleaning power

If the suction power becomes less, check the following points:

- Accessories, suction hose or suction tubes are clogged, please remove the obstruction using a stick.

Illustration **E 2**

- Flat pleated filter contaminated: Remove the filter cartridge and clean filter (see Chapter "Cleaning the flat pleated filter").
- Replace damaged flat folded filter.

Helpline

Karcher (UK) Limited operate a helpline allowing customers to discuss any problems experienced with our products.

The helpline operates during normal business hours, if you have difficulty getting through, please understand that there are peak periods during the day when our consultants are unable to take all calls coming in. In these circumstances we would ask that you try to contact us again later in the day.

The helpline number is 01295 752200, open from 8.30am to 5.00pm Monday to Friday.

It helps us if you have the model number and data plate details to hand before making your call.

Alternatively you may write or E-mail to the address below:

Karcher (UK) Limited
Karcher House
Beaumont Road
Banbury
Oxon, OX16 1TB

E-mail:
info@karcher.co.uk

Technical specifications

Voltage 1~50/60 Hz	220 - 240	V
Output P _{nom}	1000	W
Mains fuse (slow-blow)	13	A
Container ca- pacity	20	l
Water intake with handle	12	l
Water intake with floor noz- zle	10	l
Power cord	H05VV-F 2x0,75	
Sound pres- sure level (EN 60704-2-1)	72	dB(A)
Weight (with- out accesso- ries) MV 4	7,1	kg
Weight (with- out accesso- ries) MV 4 Premium	7,4	kg

Subject to technical modifications!

