

## CDC1802

(GB)	CORDLESS DRILL DRIVER	USER'S MANUAL	1
(FR)	PERCEUSE-VISSEUSE SANS FIL	MANUEL D'UTILISATION	5
(DE)	AKKU-BOHRSCHRAUBER	BIEDNUNGSANLEITUNG	10
(ES)	TALADRO-ATORNILLADOR SIN CABLE	MANUAL DE UTILIZACIÓN	15
(IT)	TRAPANO AVVITATORE A BATTERIA	MANUALE D'USO	20
(NL)	ACCU-BOORSCHROEFMACHINE	GEbruIKSINSTRUCTIES	25
(PT)	BERBEQUIM-APARAFUSADORA SEM FIO	MANUAL DE UTILIZAÇÃO	30
(DK)	BATTERIDREVEN BORE-SKRUEMASKINE	BRUGERVEJLEDNING	35
(SE)	SLADDLÖS BORRMASKIN/SKRUVDRAGARE	INSTRUKTIONSBOK	40
(FI)	JOHDOTON PORAKONE-RUUVITALTA	KÄYTTÄJÄN KÄSIKIRJA	45
(NO)	OPPLADBAR BOR-/SKRUMASKIN	BRUKSANVISNING	49
(RU)	АККУМУЛЯТОРНАЯ ДРЕЛЬ-ШУРУПОВЕРТ	РУКОВОДСТВО ПО ЭКСПЛУАТАЦИИ	53
(PL)	BEZPRZEWODOWA WIERTARKO-WKRĘTARKA	INSTRUKCJA OBSŁUGI	58
(CZ)	AKU VRTACÍ PŘIHOBOVÁK	NÁVOD K OBSLUZE	63
(HU)	FÚRÓ / CSAVAROZÓ GÉP, VEZETÉK NÉLKÜLI	HASZNÁLATI ÚTMUTATÓ	68
(RO)	MAȘINĂ DE GĂURIT ÎN ÎNCURUBAT CU ACUMULATOR	MANUAL DE UTILIZARE	73
(LV)	AKUMULATORA URBIS-SKRUVGRIEZIS	LIETOTĀJA ROKASGRĀMATA	78
(LT)	BELAIŠIO SUKTUVO -GRUOTO	NAUDOJIMO VADOVAS	82
(EE)	AKUTRELL KASUTUSJUHEND	KASUTAJAJUHEND	86
(HR)	BEKONNA BUJILICA-ODVIJAK	KORISNIČKI PRIRUČNIK	90
(SI)	AKU-VRTALNIK-VIJALNIK	UPORABNIŠKI PRIROČNIK	94
(SK)	BEZDRŔOVÁ VŤAČKA	NÁVOD NA POUŽITIE	99
(GR)	ΠΡΟΒΛΕΠΟΜΕΝΟ ΑΚΟΥΜΑΤΟΡΙΑΚΟ ΠΕΡΑΤΕΡΑΖΗΤΟ	ΕΓΧΕΙΡΙΔΙΟ ΧΡΗΣΗΣ	104
(TR)	KABLOSUZ MATKAP-TORNAVIDA	KULLANIM KILAVUZU	110

GB ORIGINAL INSTRUCTIONS FR TRADUCTION DES INSTRUCTIONS ORIGINALES DE ÜBERSETZUNG DER ORIGINALANLEITUNG ES TRADUCCIÓN DE LAS INSTRUCCIONES ORIGINALES IT TRADUZIONE DELLE ISTRUZIONI ORIGINALI NL VERTALING VAN DE ORIGINELE INSTRUCTIES PT TRADUÇÃO DAS INSTRUÇÕES ORIGINAIS DK ÖVERSÄTTELSE AF DE ORIGINALE INSTRUKTIONER SE ÖVERSÄTTNING AV DE URSPRUNGLIGA INSTRUKTIONERNA FI ALKUPERÄISTEN OHJEIDEN SUOMENNOS NO OVERSETTELSE AV DE ORIGINALE INSTRUKSJONENE RU ПЕРЕВОД ОРИГИНАЛЬНЫХ ИНСТРУКЦИЙ PL TŁUMACZENIE INSTRUKCJI ORYGINALNEJ CZ PŘEKLAD ORIGINÁLNÍCH POKYŇŮ HU AZ EREDETI ÚTMUTATÓ FORDÍTÁSA RO TRADUCEREA INSTRUCȚIUNILOR ORIGINALE LV TULKOTS NO ORIĻĪNĻS INSTRUKCIJAS LT ORIGINALIŲ INSTRUKCIJŲ VERTIMAS EE ORIGINAALJUHENDI TÖLGE HR PRIJEVOD ORIGINALNIH UPUTA SI PREVOD ORIGINALNIH NAVODIL SK PREKLAD POKYNOV V ORIGINÁLI GR ΕΓΧΕΙΡΙΔΙΟ ΧΡΗΣΗΣ ΕΓΧΕΙΡΙΔΙΟ ΧΡΗΣΗΣ TR ORIJNAL TALIMATLARIN TERCÜMESİ

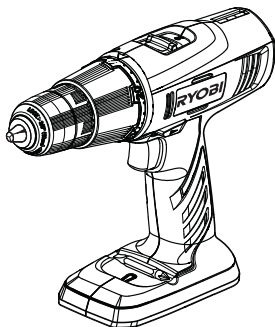

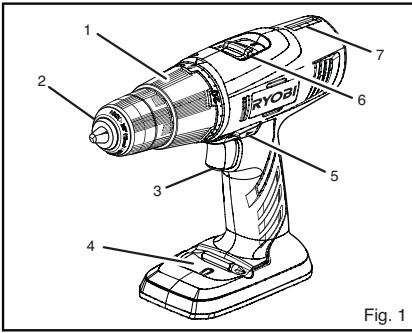

Fig. 1

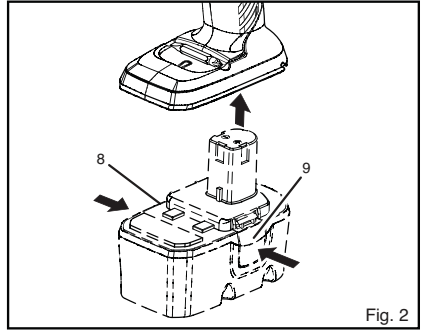

Fig. 2

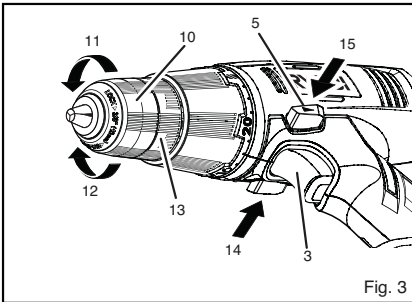

Fig. 3

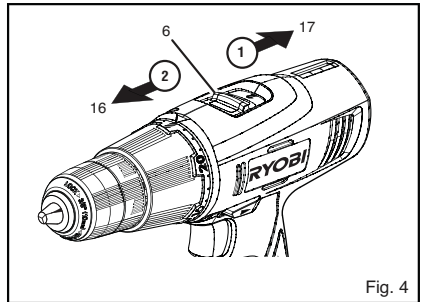

Fig. 4

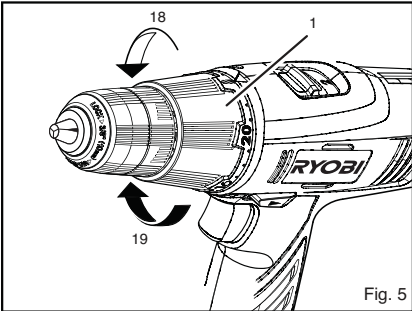

Fig. 5

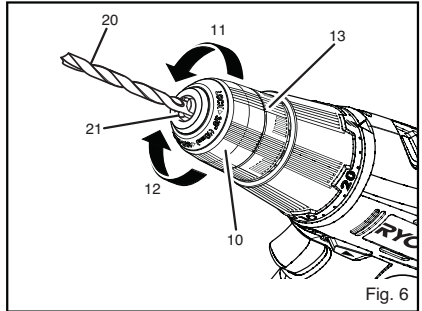

Fig. 6

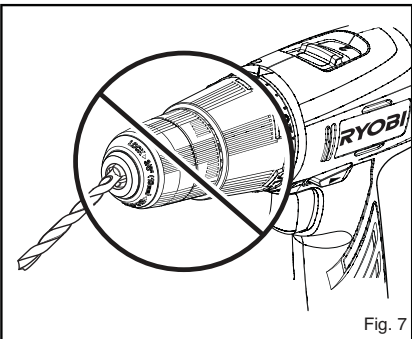

Fig. 7

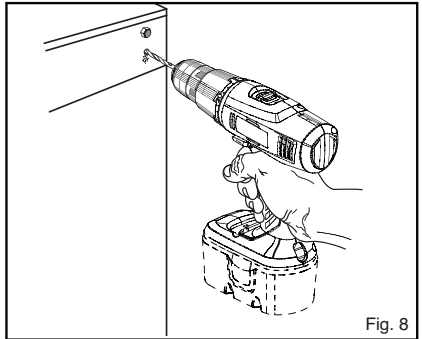

Fig. 8

<b>Important!</b>	It is essential that you read the instructions in this manual before mounting and operating this machine.
<b>Attention !</b>	Il est indispensable que vous lisiez les instructions contenues dans ce manuel avant le montage et la mise en service de l'appareil.
<b>Achtung!</b>	Bitte lesen Sie unbedingt vor Montage und Inbetriebnahme die Hinweise dieser Bedienungsanleitung.
<b>¡Atención!</b>	Es imprescindible que lea las instrucciones de este manual antes del montaje y de la puesta en servicio.
<b>Attenzione!</b>	Prima di procedere al montaggio e alla messa in funzione, è indispensabile leggere attentamente le istruzioni del presente manuale.
<b>Let op!</b>	Het is absoluut noodzakelijk vóór montage en inbedrijfstelling de aanwijzingen in deze handleiding te lezen.
<b>Atenção!</b>	É indispensável ler as instruções deste manual antes de montar e pôr em serviço.
<b>OBS!</b>	Denne brugsanvisning skal læses igennem inden monterering og ibrugtagning.
<b>Observera!</b>	Det är nödvändigt att läsa instruktionerna i denna bruksanvisning före monterering och driftsättning.
<b>Huomio!</b>	On ehdottoman välttämätöntä lukea tässä käyttöohjeessa annetut ohjeet ennen asennusta ja käyttöönottoa.
<b>Advarsel!</b>	Vennligst les instruksjonene i denne bruksanvisningen før du monterer og tar i bruk maskinen.
<b>Внимание!</b>	Перед сборкой и запуском инструмента необходимо прочесть инструкции из настоящего руководства.
<b>Uwaga!</b>	Przed montowaniem i uruchomieniem, koniecznie musicie się Państwo zapoznać z zaleceniami zawartymi w niniejszym sposobie użycia.
<b>Důležité upozornění!</b>	Před montáží nřadí a uvedením do provozu je nutné si přečíst následující pokyny.
<b>Figyelem!</b>	Feltétlenül fontos, hogy a jelen használati útmutatóban foglalt előírásokat az összeszerelés és az üzembe helyezés előtt elolvassa!
<b>Atenție!</b>	Este indispensabil să citiți instrucțiunile conținute în acest mod de utilizare înainte de montaj și de punerea în funcțiune.
<b>Uzmanību!</b>	Ir ļoti būtiski, lai jūs izlasītu norādījumus, kas sniegti šajā rokasgrāmatā, pirms ķeraties pie ierīces montēšanas un iedarbināšanas!
<b>Dėmesio!</b>	Prieš surinkdami ir paleisdami aparatą į darbą, reikia, kad jūs perskaitytumėte šiame vadove esančias instrukcijas.
<b>Tähtis!</b>	Lugege enne seadme kokkupanekut ja kasutamist kindlasti läbi selles juhendis sisalduvad eeskirjad ja juhised!
<b>Upozorenje!</b>	Važno je da upute u ovom Korisničkom priručniku pročitate prije postavljanja i uporabe ovog alata.
<b>Pomembno!</b>	Zelo pomembno je, da pred namestitvijo in prvo uporabo te naprave preberete navodila v tem priročniku.
<b>Upozornenie!</b>	Je dôležité, aby ste si pred montážou a spustením zariadenia prečítali pokyny, ktoré sa nachádzajú v tomto návode.
<b>Προσοχή!</b>	Είναι απαραίτητο να διαβάσετε τις συστάσεις των οδηγιών αυτών πριν τη συναρμολόγηση και τη θέση σε λειτουργία
<b>Dikkat!</b>	Cihazın montajından ve çalıştırılmasından önce bu kılavuzda bulunan talimatları okumanız zorunludur.

Subject to technical modifications / Sous réserve de modifications techniques / Technische Änderungen vorbehalten /  
Sujeto a modificaciones técnicas / Con riserva di eventuali modifiche tecniche / Technische wijzigingen voorbehouden /  
Com reserva de modificações técnicas / Med forbehold for tekniske ændringer / Med förbehåll för tekniska ändringar /  
Tekniset muutokset varataan / Med forbehold om tekniske endringer / Могут быть внесены технические изменения /  
Z zastrzeżeniem modyfikacji technicznych / Změny technických údajů vyhrazeny / A műszaki módosítás jogát fenntartjuk /  
Sub rezerva de modificărilor tehnice / Paturam tiesības mainīt tehniskos raksturlielumus / Pasiliekan teisę daryti techninius pakeitimus /  
Tehnilised muudatused võimalikud / Podložno tehničkim promjenama / Tehnične spremembe dopuščene/  
Technické zmeny vyhradené / Υπό την επιφύλαξη τεχνικών τροποποιήσεων / Teknik değışiklik hakki saklıdır

# English

## SPECIFIC SAFETY RULES

- **Wear ear protectors with impact drills** □ Exposure to noise can cause hearing loss.
- **Use auxiliary handles supplied with the tool** □ Loss of control can cause personal injury.
- **Hold tool by insulated gripping surfaces when performing an operation where the cutting tool may contact hidden wiring** □ Contact with a "live" wire will also make exposed metal parts of the tool "live" and shock the operator.
- **Know your power tool** □ Read operator's manual carefully □ Learn its applications and limitations, as well as the specific potential hazards related to this tool □ Following this rule will reduce the risk of electric shock, fire, or serious injury.
- **Always wear safety glasses with side shields** □ Everyday glasses have only impact resistant lenses. They are NOT safety glasses. Following this rule will reduce the risk of eye injury.
- **Protect your lungs** □ Wear a face or dust mask if the operation is dusty □ Following this rule will reduce the risk of serious personal injury.
- **Protect your hearing** □ Wear hearing protection during extended periods of operation □ Following this rule will reduce the risk of serious personal injury.
- **Battery tools do not have to be plugged into an electrical outlet** □ therefore, they are always in operating condition □ Be aware of possible hazards when not using your battery tool or when changing accessories □ Following this rule will reduce the risk of electric shock, fire, or serious personal injury.
- **Do not place battery tools or their batteries near fire or heat** □ Following this rule will reduce the risk of explosion and possibly injury.
- **Never use a battery that has been dropped or received a sharp blow** □ A damaged battery is subject to explosion. Properly dispose of a dropped or damaged battery immediately.
- **Batteries can explode in the presence of a source of ignition, such as a pilot light** □ To reduce the risk of serious personal injury, never use any cordless product in the presence of open flame. An exploded battery can propel debris and chemicals. If exposed, flush with water immediately.
- **Do not charge battery tool in a damp or wet location** □ Following this rule will reduce the risk of electric shock.
- **For best results, your battery tool should be charged in a location where the temperature is**

more than 10°C but less than 38°C □ Do not store outside or in vehicles □

- **Under extreme usage or temperature conditions, battery leakage may occur** □ If liquid comes in contact with your skin, wash immediately with soap and water, then neutralize with lemon juice or vinegar □ If liquid gets into your eyes, flush them with clean water for at least 10 minutes, then seek immediate medical attention □ Following this rule will reduce the risk of serious personal injury.
- **Save these instructions** □ Refer to them frequently and use them to instruct others who may use this tool. If you loan someone this tool, loan them these instructions also to prevent misuse of the product and possible injury.

## DESCRIPTION

1. Torque Adjustment Ring
2. Keyless Chuck
3. Switch Trigger
4. Mag Tray™
5. Rotation Selector
6. Two-Speed Gear Switch (Hi □ Lo)
7. Level
8. Battery Pack(not included)
9. Latches
10. Chuck Body
11. Unlock(Release)
12. Lock(Tighten)
13. Chuck Collar
14. Forward
15. Reverse
16. High Speed
17. Low Speed
18. To Decrease Torque
19. To Increase Torque
20. Bit
21. Chuck Vaws

## FEATURES

Voltage	18 V ---
Chuck (mm)	0-10 mm
Switch	Variable speed
No load speed (drill mode):	0-350/0-1300 min <sup>-1</sup>
Max. Torque (Nm)	42.6
Weight - console (KG)	1.27





# English

## FEATURES

MODEL	BATTERY PACK (not included)	CHARGER (not included)
CDC1802	BPP-1815 BPP-1815M BPP-1817 BPP-1817M BPL-1820 BPL-1815	BCL-1800 BCL1418 BCS618
	BPP-1815 BPP-1815M BPP-1817 BPP-1817M	BC-1815S BC-1800

## OPERATION

 **WARNING:**  
Do not allow familiarity with products to make you careless. Remember that a careless fraction of a second is sufficient to inflict serious injury.

 **WARNING:**  
Always wear safety goggles or safety glasses with side shields when operating products. Failure to do so could result in objects being thrown into your eyes, resulting in possible serious injury.

 **WARNING:**  
Do not use any attachments or accessories not recommended by the manufacturer of this product. The use of attachments or accessories not recommended can result in serious personal injury.

### TO INSTALL BATTERY PACK(not included)

See Figure 2.

- Place the rotation selector in center position.
- Align raised rib on battery pack with groove in drill's battery port.
- Make sure the latches on each side of the battery packsnap in place and that battery pack is secure before beginning operation.

### TO REMOVE BATTERY PACK(not included)

- Place the rotation selector in center position.
  - Locate latches on side of battery pack and depress both sides to release battery pack from the drill.
- Remove battery pack from the drill.

## BATTERY PROTECTION FEATURES

Ryobi 18 V lithium-ion batteries are designed with features that protect the lithium-ion cells and maximize battery life. Under some operating conditions, these built-in features may cause the battery and the tool it is powering to act differently from nickel-cadmium batteries.

During some applications, the battery electronics may signal the battery to shut down, and cause the tool to stop running. To reset the battery and tool, release the trigger and resume normal operation.

**NOTE:** To prevent further shut down of the battery, avoid forcing the tool.

If releasing the trigger does not reset the battery and tool, the battery pack is depleted. If depleted, the battery pack will begin charging when placed on the lithium-ion charger.

 **WARNING:**  
Battery products are always in operating condition. Therefore, the switch should always be locked when not in use or when carried at your side.

### SWITCH TRIGGER (See Figure 3.)

To turn the drill **ON**, depress the switch trigger. To turn it **OFF**, release the switch trigger.

### VARIABLE SPEED

The switch trigger delivers higher speed and torque with increased trigger pressure and lower speed with decreased trigger pressure.

**NOTE:** You might hear a whistling or ringing noise from the switch during use. Do not be concerned; this is a normal part of the switch function.

### ROTATION SELECTOR (FORWARD/REVERSE/CENTER LOCK)

See Figure 3.

The direction of bit rotation is reversible and is controlled by a selector located above the switch trigger. With the drill held in normal operating position, the rotation selector should be positioned to the left of the switch trigger for drilling. The drilling direction is reversed when the selector is to the right of the switch trigger.

Setting the rotation selector in the **OFF** (center lock) position helps reduce the possibility of accidental starting when not in use.

 **CAUTION:**  
To prevent gear damage, always allow the chuck to come to a complete stop before changing the direction of rotation.

# English

## OPERATION

To stop the drill, release the switch trigger and allow the chuck to come to a complete stop.

**NOTE:** The drill will not run unless the rotation selector is pushed fully to the left or right.

Avoid running the drill at low speeds for extended periods of time. Running at low speeds under constant usage may cause the drill to become overheated. If this occurs, cool the drill by running it without a load and at full speed.

### KEYLESS CHUCK (See Figure 3.)

The drill has a keyless chuck to tighten or release drill bits in the chuck jaws. Grasp and hold the collar of the chuck with one hand. Rotate the chuck body with your other hand. The arrows on the chuck indicate which direction to rotate the chuck body in order to **LOCK** (tighten) or **UNLOCK** (release) the drill bit.



#### WARNING:

Do not hold the chuck body with one hand and use the power of the drill to tighten the chuck jaws on the drill bit. The chuck body could slip in your hand, or your hand could slip and come in contact with the rotating drill bit. This could cause an accident resulting in serious personal injury.

### TWO-SPEED GEAR SWITCH (See Figure 4.)

The drill has a two-speed gear switch designed for drilling or driving at LO (1) or HI (2) speeds. A slide switch is located on top of the drill to select either **LO (1)** or **HI (2)** speed. When using drill in the **LO (1)** speed range, speed will decrease and unit will have more power and torque. When using drill in the **HI (2)** speed range, speed will increase and unit will have less power and torque. Use **LO (1)** speed for high power and torque applications and **HI (2)** speed for fast drilling or driving applications.

### ADJUSTABLE TORQUE CLUTCH

This product is equipped with an adjustable torque clutch for driving different types of screws into different materials. The proper setting depends on the type of material and the size of screw you are using.

### ADJUSTING TORQUE (See Figure 5.)

There are twenty-four torque indicator settings located on the front of the drill.

- Rotate adjustment ring to the desired setting.
  - 1 - 4 For driving small screws
  - 5 - 8 For driving screws into soft material
  - 9 - 12 For driving screws into soft and hard materials
  - 13 - 16 For driving screws in hard wood

- 17 - 20 For driving large screws
- 21 - For heavy drilling

### INSTALLING BITS (See Figure 6-7.)

- Lock the switch trigger by placing the rotation selector in the center position.
- Open or close the chuck jaws to a point where the opening is slightly larger than the bit size you intend to use. Also, raise the front of the drill slightly to keep the bit from falling out of the chuck jaws.
- Insert the drill bit.
- Tighten the chuck jaws on the drill bit. To tighten, grasp and hold the collar of the chuck with one hand, while rotating the chuck body with your other hand.

**NOTE:** Rotate the chuck body in the direction of the arrow marked **LOCK** to tighten the chuck jaws.



#### WARNING:

Make sure to insert the drill bit straight into the chuck jaws. Do not insert the drill bit into the chuck jaws at an angle then tighten, as shown in figure 7. This could cause the drill bit to be thrown from the drill, resulting in possible serious personal injury or damage to the chuck.

**NOTE:** Do not use a wrench to tighten or loosen the chuck jaws.

### REMOVING BITS (See Figure 6.)

- Place the rotation selector in center position. This will lock the switch trigger in the off position.
  - Loosen the chuck jaws from the drill bit.
  - To loosen the chuck jaws from the drill bit, grasp and hold the collar of the chuck with one hand, while rotating chuck body with your other hand.
- NOTE:** Rotate chuck body in the direction of the arrow marked **UNLOCK** to loosen chuck jaws.
- Remove drill bit from chuck jaws.

### DRILLING (See Figure 8.)

A level is located on top of the motor housing to help keep the drill bit level during use.

- Check the rotation selector for the correct setting (forward or reverse).
- Secure the material to be drilled in a vise or with clamps to keep it from turning as the drill bit rotates.
- Hold the drill firmly and place the bit at the point to be drilled.
- Depress the switch trigger to start the drill.
- Move the drill bit into the workpiece, applying only enough pressure to keep the bit cutting. Do not force the drill or apply side pressure to elongate a hole. Let the tool do the work.

# English

## OPERATION



### WARNING:

Be prepared for binding at bit breakthrough. When these situations occur, the drill has a tendency to grab and kick in the opposite direction and could cause loss of control when breaking through material. If not prepared, this loss of control can result in possible serious injury.

- When drilling hard, smooth surfaces, use a center punch to mark the desired hole location. This will prevent the drill bit from slipping off-center as the hole is started.
- When drilling metals, use a light oil on the drill bit to keep it from overheating. The oil will prolong the life of the bit and increase the drilling action.
- If the bit jams in the workpiece or if the drill stalls, stop the tool immediately. Remove the bit from the workpiece and determine the reason for jamming.

**NOTE:** This drill has an electric brake. When the switch trigger is released, the chuck stops turning. When the brake is functioning properly, sparks will be visible through the vent slots on the housing. This is normal and is the action of the brake.

## WOOD DRILLING

For maximum performance, use high speed steel bits for wood drilling.

- Begin drilling at a very low speed to prevent the bit from slipping off the starting point. Increase the speed as the drill bit bites into the material.
- When drilling through holes, place a block of wood behind the workpiece to prevent ragged or splintered edges on the back side of the hole.

## METAL DRILLING

For maximum performance, use high speed steel bits for metal or steel drilling.

- Begin drilling at a very low speed to prevent the bit from slipping off the starting point.
- Maintain a speed and pressure which allows cutting without overheating the bit. Applying too much pressure will:
  - Overheat the drill;
  - Wear the bearings;
  - Bend or burn bits;
  - Produce off-center or irregular-shaped holes.
- When drilling large holes in metal, start with a small bit, then finish with a larger bit. Also, lubricate the bit with oil to improve drilling action and increase bit life.

## MAINTENANCE



### WARNING

When servicing, use only identical Ryobi replacement parts. Use of any other parts may create a hazard or cause product damage.

Avoid using solvents when cleaning plastic parts. Most plastics are susceptible to damage from various types of commercial solvents and may be damaged by their use. Use clean cloths to remove dirt, dust, oil, grease, etc.



### WARNING

Do not at any time let brake fluids, gasoline, petroleum-based products, penetrating oils, etc. come in contact with plastic parts. They contain chemicals that can damage, weaken or destroy plastic.

## ENVIRONMENTAL PROTECTION



Recycle raw materials instead of disposing as waste. The machine, accessories and packaging should be sorted for environmental-friendly recycling.

## SYMBOL



Safety Alert



Volts



Revolutions or reciprocations per minute



Direct current



CE Conformity



Please read the instructions carefully before starting the machine.



Recycle unwanted



Waste electrical products should not be disposed of with household waste. Please recycle where facilities exist. Check with your Local Authority or retailer for recycling advice.